

Case Number:
23-102980 RZ

Summary of Process

- The Staff evaluation of an application will be presented at the required Planning Commission and Board of County Commissioners' Hearings.
- The Planning Commission will review the evidence and will make a recommendation to the Board of County Commissioners.
- The final decision on the request will be made by the Board of County Commissioners.

Case Summary

To construct a day-use lift-served bike park as a Class III Commercial Recreation Facility

Purpose

Shadow Mountain Bike Park		Dylan Monke		March 17, 2023		
Case Name		Case Manager		Formal Submittal Date		
June 9, 2022	July 27, 2022	September 11	October 1	Site Development Plan		
Pre-Application Date		Community Meeting Date		PC Hearing Date		BCC Hearing Date
Phillip Bouchard & Jason Evans		Colorado State Land Trust				
Applicant/Representative, check if same as owner: <input type="checkbox"/>		Owner				
61-163-00-00	Conifer	80433	235 Acres	16	6	71
Property Address	City	Zip	Area ≈	Section	Township	Range
61-163-00-001	Southwest of the intersection of Shadow Mountain Drive and south Warhawk Road					
Pin	General Location					

Land Use and Zoning

Vicinity

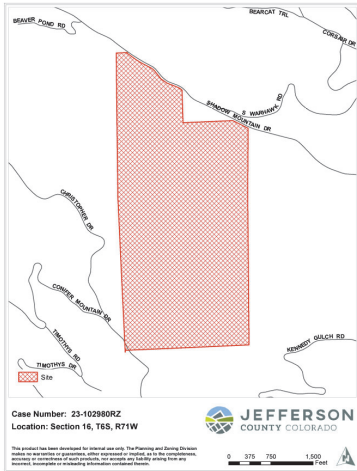

Detail

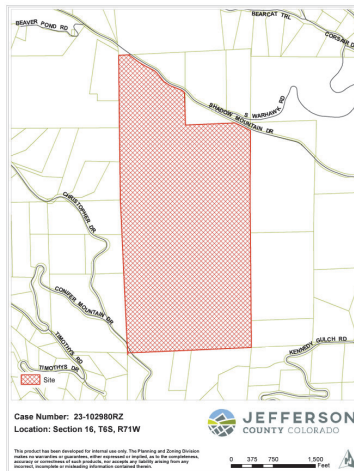

Surrounding Zoning

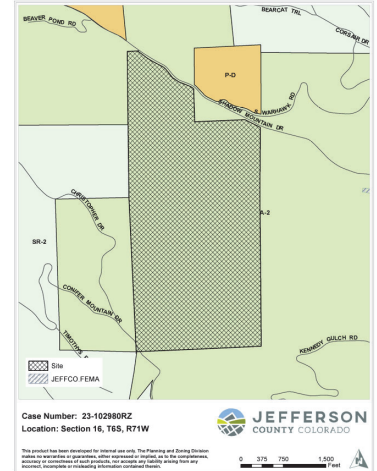

Existing Land Use:

Agricultural Leases/Vacant

Existing Zoning:

Agricultural Two (A-2)

CMP Recommended Land Use:

1 Dwelling Unit per 10 Acres

Requested Zoning:

Special Use - Recreational Facility III

Plan Area: Conifer/285 Corridor Area

Number of citizens at Community Meetings: ~332

PC Recommendations: _____

Level of Community Interest: High

Key Issues: Wildfire, traffic, wildlife

Criteria for Rezoning:

- The compatibility with existing and allowable land uses in the surrounding area.
- The degree of conformance with applicable land use plans.
- The ability to mitigate negative impacts upon the surrounding area.
- The availability of infrastructure and services.
- The effect upon the health, safety, and welfare of the residents and landowners in the surrounding area.

✓	○	✗
☒	☐	☐
☐	☐	☒
☒	☐	☐
☒	☐	☐
☒	☐	☐

STAFF REPORT

1. SUBJECT REQUEST

The subject property, a portion of current Assessor Parcel ID (AIN) 61-163-00-001, south and west of the intersection of Shadow Mountain Drive and South Warhawk Road, is owned by the State of Colorado. The applicant and the State of Colorado entered into Recreation Planning Lease No. 11388 (Lease) for the subject property. Pursuant to paragraph 3 of the Lease “[t]he use of the Premises shall be limited to recreation development evaluation and studies for a proposed mountain biking park and associated facilities.”

The applicant is seeking a Special Use for the subject property. The State of Colorado owns all of current Assessor Parcel ID (AIN) 61-163-00-001. Only the portion of that parcel more particularly described in the legal description on the proposed Special Use Document (SUD) would be governed by the SUD, if this application is approved. The portions of Assessor Parcel ID (AIN) 61-163-00-001, north of Shadow Mountain Drive and east of South Warhawk Road are not proposed for any change with this request.

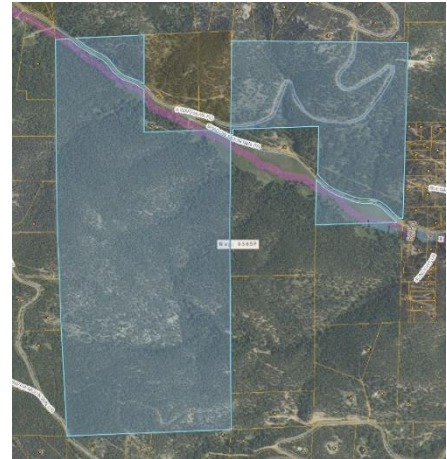

Aerial image of subject property

The applicant is proposing the SUD for the estimated 235-acre portion to allow for the construction of a day-use, lift-served bike park as a Class III Commercial Recreation Facility, pursuant to the definition for such a facility in the Zoning Resolution, with adjustments. The proposed request seeks to exclude some of the most impactful components allowed under Class III Recreational Facilities such as: motorized equipment, firearms and/or animals.

2. CONTEXT

The subject property is zoned Agricultural Two (A-2).

The permitted uses of the Agricultural Zone District allow for Class II Recreation Facilities. However, the applicant seeks to exceed the building size limitations of the existing entitlements. The Zoning Resolution defines the difference between Class II and Class III as follows:

RECREATION FACILITIES:

2. CLASS II: *Facilities for sports and recreational activities that do not involve organized events which include motorized equipment, firearms or animals, except that golf carts accessory to a golf course and private motorized boats not involved in organized racing are allowed. All buildings housing such activities or accessory to such activities may not exceed a combined total of 15,000 square feet.*

3. CLASS III: *Facilities for the purpose of sports and recreational activities including those that involve organized events which include the use of motorized equipment, firearms, and/or animals. There is no building size limitation except as may be designated elsewhere in this Zoning Resolution or other applicable regulations.*

The proposed SUD includes two principal Use Areas, A & B. Use Area A proposes uses for a 15,000 sq. ft. day-use lodge, parking and an access roadway. Use Area B proposes uses of a 5,000 sq. ft. maintenance building, trails, and a chairlift.

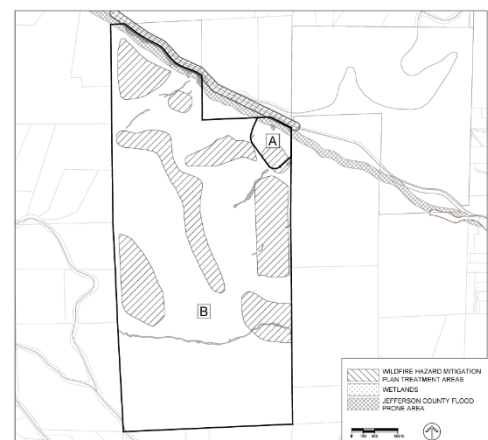

Special Use Document Area Map

Portions of the property are in wetland and floodplain areas and the entire property is within the Wildland Urban Interface Overlay District. Each of these physically constrained areas have individual restrictions proposed to limit development impacts to them. The SUD proposes further limits on aspects of evening and seasonal closures, lighting, signage, sound, fencing, architecture, parking, and waste management.

3. SURROUNDING ZONING/LAND USE

	Adjacent Zoning	Land Use
North:	A-2, PD	Single-family Residential
South:	A-2	Single-family Residential
East:	A-2	Single-family Residential
West:	A-2, SR-2	Single-family Residential

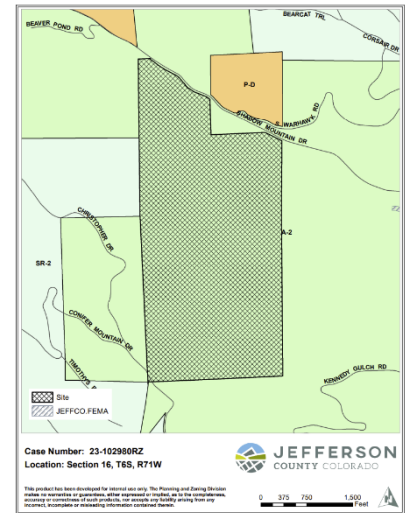

Subject property and surrounding zoning

4. SUMMARY OF PROPOSED CHANGES

	Current Zoning	Proposed Zoning
Land Use	Single Family Dwelling, Barn, Stables, General Farming, Dairy, Public Park, Veterinary Hospital, Cemetery, Telecommunication and other farming uses.	Class III Recreational Uses excluding motorized vehicles, firearms, and/or animal uses.
Setbacks	<p>Residential 50-foot front 30-foot side 50-foot rear</p> <p>Livestock 75-foot front 75-foot side 50-foot rear</p>	<p>Day-Use Lodge 300-foot front 100-foot from all other SUD boundaries</p> <p>Parking, Water Storage, Maintenance Road & all Trails 50-foot from all SUD boundaries</p> <p>Chairlift 150-foot from all SUD boundaries</p>
Building Height	35-foot	<p>Building & Chairlift No changes</p>
Parking	3.5 per dwelling unit	<p>1 space per occupancy rating of proposed lodge not to exceed 320 spaces.</p> <p>Only permitted in designated spaces</p>
Design	No restrictions	Mountain Style architecture required. Flat roofs prohibited, natural color palette, low reflectivity,

5. TRANSPORTATION

The subject property is adjacent to Shadow Mountain Drive, a County-maintained Collector Road. Shadow Mountain Drive is a 2-lane, striped, and paved mountain road with some topography and circuitous lengths. Planning Engineering has no concerns with the proposed roadway carrying capacity but has notified the applicant that if this application is approved, a left-turn lane into the development would be required to be constructed by the applicant at the time of Site Development Plan.

The applicants prepared a transportation study reviewed by staff. The study estimates a weekday average of 520 daily trips, 260 vehicles into the site and 260 out of the site. During the morning peak hour there would be an estimated 115 trips into the site and 11 vehicles exiting, and the evening peak hour would see 8 vehicles entering and 80 exiting. On Saturdays and Sundays, the average daily trips is estimated to increase to 1,000 daily trips. During the morning peak hour 220 vehicles would enter and 21 would exit. For this study, a Saturday and Sunday mid-day peak hour was also analyzed showing 15 vehicles entering and 155 exiting. Jefferson County is proposing a roundabout in the area at the intersection of County Highway 73 and Barkley Road regardless of the outcome of this request. If this Special Use should be approved, an additional roundabout would be required at the intersection of County Highway 73 and Shadow Mountain Drive with the developer contributing money to the construction of this roundabout. With the roundabout additions, traffic is expected to operate at an acceptable Level of Service (LOS) at the impacted intersections.

The submitted transportation study also shows in the existing conditions that speeds can often exceed the speed limit imposed on Shadow Mountain Road which may make for unsafe conditions. Winter conditions may exacerbate these conditions.

6. CRITERIA FOR DECISIONS FOR REZONING & SPECIAL USE APPLICATIONS

Section 6 of the Zoning Resolution states, *in reviewing Rezoning and Special Use applications, the Planning Commission and the Board of County Commissioners may consider the following criteria:*

- ✓ a. *The compatibility with existing and allowable land uses in the surrounding area.*
 - ✗ b. *The degree of conformance with applicable land use plans.*
 - ✓ c. *The ability to mitigate negative impacts upon the surrounding area.*
 - ✓ d. *The availability of infrastructure and services.*
 - ✓ e. *The effect upon the health, safety, and welfare of the residents and landowners in the surrounding area.*
-

a. The compatibility with existing and allowable land uses in the surrounding area.

Staff found that the proposed use is compatible with the existing and allowable land uses in the surrounding area based on two distinct components, a) the current A-2 Zoning for the subject property and in the surrounding area (the subject property is surrounded by A-2 zoning on all sides) allows for public parks and Class II recreational facilities and, b) The restrictions proposed in the SUD limit the number and size of buildings, lighting, architecture, and the volume of visual impacts, more so than the surrounding A-2 zone districts. Written restrictions limit the 235-acre portion of the parcel to a maximum of two buildings. The maximums are 15,000 square feet in Use Area A and 5,000 square feet in Use Area B. A-2 zoning allows for dwellings, agricultural buildings and barns to be constructed at unlimited size when parcels meet the 10-acre minimum lot size. Occupancy and operation proposed in the SUD would be required at larger setbacks than in the surrounding A-2 zone district. Structures proposed would require a 300-foot front setback instead of 50-foot front and 100-foot from sides where 30-foot are currently required.

The SUD also includes architectural restrictions that would limit the construction type of the building to mountain appropriate architectural designs. Restrictions include neutral palette of red, brown and black of

the surrounding area, low reflective materials, pitched or planarly angled roofs to mirror existing hillsides and treatments to reflective materials to further reduce reflectivity.

Building footprints are also limited to a cumulative 20,000 square feet across the entire 235-acre parcel whereas dwellings, barns and agricultural uses on parcels of 10-acres or more are allowed an unlimited size restricted only by setbacks.

Maintenance roads are also required to be a minimum of 50-foot from any property lines which is expected to minimize site grading, reduce significant clearing of vegetation and remove large cut/fill scarring typical with many private mountain driveways.

Staff finds that the written restrictions limiting building size and location, requiring trails and maintenance roads to be setback at least 50 feet from property lines, the chairlift to be setback 150 feet from property lines, requiring residential noise impacts, and other restrictions of the SUD make this use compatible with the existing and allowed uses in the surrounding area. Staff also finds that parks are generally compatible with residential and agricultural land uses throughout the County.

b. The degree of conformance with applicable land use plans.

The Comprehensive Master Plan (CMP), an advisory document required by State statute, contains Goals and Policies that are used to guide land use decisions. The Area Plans section of the CMP contains supplementary policies and land use recommendations for evaluation.

	Summary	Conforms with CMP? ✓ ○ ✗
Land Use	The CMP discusses the need for a variety of uses to create a vibrant, enduring community. The Plan encourages diverse communities in which to live, work, and enjoy outdoor recreation.	✗
Physical Constraints	The CMP describes physical constraints as those physical features that due to safety concerns may potentially restrict where and how development occurs. Physical Constraints include geologic hazards and constraints, floodplains, wetlands, wildfire, radiation, landfills, abandoned mines, and wildlife habitat	✓
Community Resources	The CMP contains policies that relate to historic structures or sites, scenic corridors, natural features, air quality, light, odor and noise pollution, open space and trails.	✓
Infrastructure Water and Services	The CMP describes the importance of new developments having adequate Transportation, Water and Wastewater, and Services.	✓

Staff concludes that the subject request is not general conformance with the applicable goals and policies of the Comprehensive Master Plan (CMP or Plan).

Land Use: The subject property is within the Conifer/285 Corridor Area Plan. The property is within an area recommended for 1 dwelling unit per 10-acre parcel of land. This would allow for approximately 23 buildable lots. The proposed Class III Commercial Recreation Facility land use does not fit the definition of a Residential use or Community Use. So, the proposal was evaluated as an application out of conformance with the Comprehensive Master Plan. The proposal was evaluated against three factors:

A. *How the impacts associated with the proposed land use(s) will be mitigated compared with the recommended Land Uses;*

The applicants have stated that this SUD includes a number of mitigation measures to increase the compatibility with surrounding residential uses, including lighting and noise restrictions, limitations on parking capacity, limitations on visitation and facility size, and tracking measures for management. They also state the increased traffic is consistent with Open Space parks and State Parks.

Staff notes that while this is true, the factor to be addressed states that the evaluation is to be a comparison of impacts to the uses recommended by the Plan. In this case, the Plan recommends residential with a density of one dwelling per 10 acres. The type of development recommended by the Plan would have much less of an impact in terms of traffic.

While the road network can handle the projected traffic generated by the proposed use, this amount of traffic is greater than what would be expected for 23 single-family dwelling units. This is especially true for weekends, where the trips are projected to be 4 times the number of trips of the Plan recommendations. The result is that the proposed land use will have greater impacts on traffic compared to what would be generated by the recommended land use. This is evidenced by the need for a second roundabout at the intersection of County Highway 73 and Shadow Mountain Drive, discussed in paragraph 5 (Transportation) above, should the proposed use be operated.

Staff finds that this factor has not been adequately addressed.

B. *How the proposed land uses are compatible with the surrounding Land Use Recommendations and community character?*

The applicants argue that it has been demonstrated throughout Jefferson County that large lot residential/agricultural developments are compatible with large open space/recreation areas. Staff agrees that these uses are compatible, however these uses, where they exist in the County, are primarily for passive recreation, and not a more active form of recreation as proposed. However, the SUD does contain written restrictions which would lend to greater compatibility by concentrating the infrastructure of the development closer to Shadow Mountain Drive, and pushing the trails, access road, and lifts away from adjacent residential and agricultural uses.

Building architecture is limited in the SUD to color and style most similar to residential structures and limited in height to match that of the zoning in the surrounding area. Parking lot areas are also required to be landscaped with clustered trees and shrubs to screen surrounding uses from the constructed lot.

Trail and chairlift clearing widths are proposed at a maximum of 30-foot to mitigate potential for clear cutting forest trees and preserve natural vegetation, which would have a similar impact as an access road for potentially 23 individual lots as allowed by the current zoning.

The document also limits illumination in various ways including prohibiting illumination of signs, floodlights, hazard areas, in the larger Use Area B, with exception of the chairlift. Illumination is also prohibited above any building fascia or roofline. Sound is limited to residential maximum uses and outdoor amplification is prohibited.

Staff finds that this factor has been adequately addressed.

C. *What change of circumstance has occurred in the local area since the Land Use Recommendation was adopted?*

The applicant contends that the increased demand for recreational use has significantly impacted existing trails creating conflict and the need for additional facilities. The applicant further states these demands are reflected in Jefferson County through the establishment of designated bike-only use trails and operation in Jefferson County Open Space (JCOS) and

increased visitation numbers at the nearby Staunton State Park. The claim from the applicants is that approval of this Special Use would help to alleviate user conflicts in JCOS parks among mountain bikers, hikers, and equestrian users which they claim have increased since the COVID-19 pandemic as park use overall has increased.

Jefferson County Open Space had no comments on this case. So, staff was unable to evaluate the information provided by the applicant, with insight from JCOS. Although JCOS does have trails designated for mountain bikers only in various parks as well as scheduled mountain bike only days in at least one park, staff could not confirm with referral agencies if the proposed Special Use is anticipated to lessen user conflicts by reducing the demand by mountain bikers on other public parks. Further, a general level of increased park visitation is not a change of circumstances *in the local area*. There have been no changes in land use, no significant road improvements nor any other development in the local area that would make the land use recommended by the Plan no longer valid.

Overall, staff finds that the applicants have not satisfactorily addressed two of the three factors for proposals out of conformance with the land use recommendations.

Physical Constraints:

The subject property contains portions of floodprone area, portions of a wetland, high wildfire hazard rating and portions of steep topography.

The SUD has explicit restrictions to prohibit construction, parking lots and trails within the floodplain and wetland areas. Setbacks of buildings is proposed at 300-foot front (from Shadow Mountain Drive) and 100-foot sides, which would not permit these within the reach of those areas. The only allowed disturbance in these areas proposed is the principal and secondary access point to Shadow Mountain Drive. If this special use is approved, during a subsequent process, these access drives would require a Floodplain Permit and all standards of the Section 37 – Floodplain Overlay District must be met.

This parcel has significant wildlife habitat as described by Colorado Parks and Wildlife as “category 4 Crucial Big Game Habitat” whose primary threat is residential and commercial development. The Comprehensive Master Plan recommends this area for 1 dwelling unit per 10 acres. However, the existing Agricultural Two (A-2) zoning allows for many intensive agricultural uses and would not limit the number of horses permitted on lots that meet the lot size or restrict where they would be allowed to peruse and graze. The A-2 zone district also allows for more intensive agricultural uses such as dairy farms, barns and poultry hatcheries and public parks including Class II public recreation facilities. The existing zoning and the zoning of the surrounding area would not require similar restrictions to limit animal impacts to these areas, buffer their occupation of riparian areas on-site, limit their occupancy to daylight hours or maintain a seasonal closure. The A-2 zone district would also allow fencing (no wildlife-friendly requirement) up to 7 feet tall while the proposed SUD requires that any fencing be wildlife-friendly fencing.

The subject property is within the Wildland Urban Interface Overlay District. The applicants have provided a Wildfire Hazard Mitigation Plan which will be implemented at the time of Site Development Plan and Building Permit, if this Special Use is approved, and is discussed in more detail below.

Staff believes this of physical constraints policies has been met.

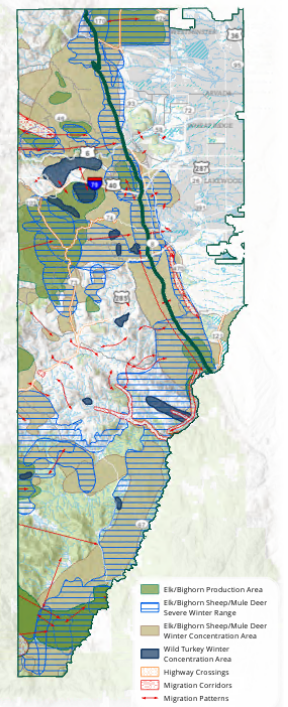

Colorado Parks & Wildlife GIS Data Map

Community Resources:

The applicant has worked with the Jefferson County Historical Commission to survey the site for historical, archeological and paleontological resources and found no evidence of their existence. At the request of the Jefferson County Historical Commission, and due to the size of the subject property, the applicant has agreed to conduct a Historical, Archaeological and Paleontological Report/Plan in accordance with the Land Development Regulation with their Site Development Plan submittal if this SUD were approved.

The SUD has specific provisions to mitigate light and noise pollution beyond the existing A-2 requirements. No adverse impact is expected from these two components beyond what typical residential development would cause. The applicant has provided enforceable language to require residential noise standards to apply to this parcel.

There are no known open space or trail impacts expected.

Infrastructure, Water and Services:

The applicant intends to obtain a nonexempt commercial well and pursue an augmentation plan to obtain water rights for development at the time of SDP. The County Geologist completed two Water Availability Analysis (WAA) studies for the proposed development. The initial WAA assumed 12 gallons per day per user. This volume assumption was reduced to 4 gallons per day per user following the provision of updated data from the applicant taken from similar and comparable uses at Loveland Ski Area and Staunton State Park. The County found this data applicable and useable. The results of the second WAA conclude that the proposed use is not anticipated to negatively affect the applicable water basin, causing it to function at a deficit.

During a subsequent County process, if the proposed use is deemed to need an On-site Wastewater System (OWTS) of less than 2,000 gallons per day, the Jefferson County Public Health Department will process this permit in accordance with their Commercial regulatory requirements. Should the system design exceed 2,000 gallons per day, CDPHE will be the governing agency for a Public Water System. Neither of the standard regulations are being considered for variation and all of those respective standards would need to be met, if the SUD were approved by the Board of County Commissioners.

The property will be serviced by Elk Creek Fire Protection District who has provided a letter detailing the fire truck movements on-site, which would be designed during a subsequent County application process, that would be needed to service the property. Applicants will also provide on-site Emergency Medical Services (EMS) as first-point of contact for visitors of the park in need of medical services. Law enforcement services are provided by the Jefferson County Sheriff's Office.

Shadow Mountain Drive is a two-lane paved County-maintained Collector Road. Transportation & Engineering have noted the infrastructure has or will have adequate capacity to support the proposed use. The Level of Service (LOS) of impacted intersections is expected to operate at acceptable levels provided the installation of roundabouts is constructed in conformance with County expectations.

Staff concludes that proposal is in conformance with the infrastructure, water and services section of the CMP and that services are available and are adequate to service the proposed use.

c. The ability to mitigate negative impacts upon the surrounding area.

The ability to mitigate negative impacts on the surrounding area have been considered.

Proposed setbacks are significantly larger than those of the surrounding area. These proposed distances are expected to mitigate impacts to the surrounding area by concentrating use further from any adjacent neighbors or passing traffic.

The proposed Wildfire Hazard Mitigation Plan seeks to reduce the wildfire risk of the subject 235-acre parcel as well as portions of the adjacent Right-Of-Way and further east off-site between intersections of Buena Vista Drive and Sprucedale Drive. The plan includes these sections to provide evacuating residents and incoming firefighters adequate space to drive and turn around engines without endangering their passengers.

The proposed use is expected to increase traffic along Shadow Mountain Drive. However, this roadway has been constructed as a Collector Road with adequate surface and striping to accommodate the proposed additional traffic. If approved, there would likely be a requirement for a left turn lane into the site as well as two roundabout improvements. The proposed park will also have a seasonal closure proposed for the Winter months where inclement weather is most common and hours between twilight and dawn where early frosts have a tendency to linger. These two restrictions are expected to decrease potential crashes and transportation impacts to adjacent residential areas.

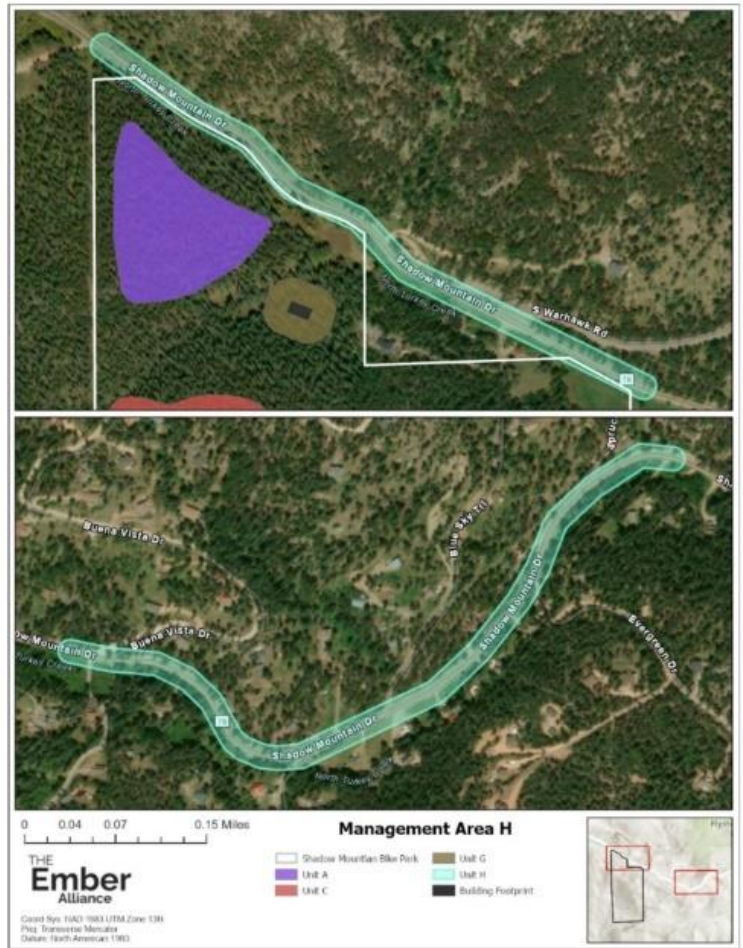

Public ROW Wildfire Mitigation

During the review of this case, visual impacts was noted as a primary citizen concern on multiple occasions. Staff believes the visual impact will be similar or less than the recommended residential use. The proposed use has development focused in a particularly small area of a very large lot. The visual impacts of the proposal are expected to be minimized by significantly larger setbacks, limited to two buildings total, a single maintenance road up the mountain area and narrow clear-cutting maximums for trails and the lift-corridor.



Existing Shadow Mountain Drive Overhead Powerline Corridor



Visual Rendering of Proposed lift corridor

Visual impacts were further analyzed against existing electrical powerline clearcuts. The chairlift is anticipated to be nearly equally visually impactful if new overhead poles are required to service 23 residences sited at on the parcel. While the chairlift towers are proposed taller than the existing service poles, they would be sited much farther back from Shadow Mountain Drive where infrastructure now exists crisscrossing overhead.

The existing zoning allows for barns of unlimited size with no architectural restrictions and significant clear-cutting to allow for large animal boarding, grazing and riding, pictured beside. The SUD includes restrictions to require natural colors, pitched rooves, low reflectivity and compatibility with surrounding structures.

Staff concludes that the applicant has adequately mitigated potential negative impacts on the surrounding area through the development requirements set forth in the SUD.



Permitted barn and riding arena in vicinity

d. The availability of infrastructure and services.

Staff concludes that there is existing and available infrastructure and services. The infrastructure and services are available and adequate to support the proposed Special Use, as stated above.

e. The effect upon health, safety, and welfare of the residents and landowners in the surrounding area.

The proposed land uses will not result in significant impacts to the health, safety, and welfare of the residents and landowners in the surrounding area. No unmitigated negative effects relating to the proposed Special Use have been identified.

7. COMMERCIAL MINERAL DEPOSITS

No known commercial mineral deposits exist on the subject property.

8. COMMUNITY MEETING

A Community Meeting was held on January 5, 2021, and July 27, 2022. There were approximately 300 attendees for the first meeting and 332 attendees for the second meeting. Both meetings had members of the public opposed and in support. Concerns primarily focused on compatibility, traffic, wildfire, commercial use and public safety. Please see the attached Community Meeting Summary for more information.

9. COMMUNITY/REFERRAL RESPONSES

Staff has collected a total of 708 public comments as of the writing of this staff report. These comments covered a wide variety of topics including, but not limited to:

Compatibility
 Land Use
 Wildlife
 Wildfire and evacuation
 Property Values
 Recreation and User Conflict
 Transportation
 Public safety
 Conservation areas
 Floodplain and Wetlands

All public comments have been forwarded to the applicant at regular intervals and between referrals. The SUD has had iterations reflective of public comments and concerns at each referral response in attempts to mitigate these expressed concerns. All public comments received at the time this Staff Report was posted on the County's website, have been included as an Addendum to the Hearing Packet.

10. AGENCY REFERRAL RESPONSES

This application was sent on referral to 12 Jefferson County Departments & Divisions and 20 external agencies (please see the first referral matrix in the case packet for more information). **There is one outstanding issue** with the referral agencies.

The Colorado Division of Parks and Wildlife (CPW) have noted many concerns from the first referral. Response from the 2nd referral show 12 recommendations for the applicant:

1. Implement a seasonal closure on construction activity and commercial operation from January 1 through July 1 to limit disturbance on wintering and newly born wildlife.
2. Require the use of bear resistant / bear proof trash cans and trash dumpsters for storage and disposal of waste on the property.
3. Prohibit bird feeders on the property between April 1st and the Thanksgiving holiday to prevent attracting black bears.
4. Prohibit feeding of all other wildlife on the property.
5. Prohibit outside composting, except when completely enclosed by electrified fencing.
6. Construction of any fencing to be completed in accordance with CPW recommended standards as outlined in the "Fencing With Wildlife in Mind" document <https://cpw.state.co.us/Documents/LandWater/PrivateLandPrograms/FencingWithWildlifeInMind.pdf>
7. Install round doorknobs on all exterior doors instead of lever style doorknobs to help prevent black bears from accessing unlocked doors.
8. Install motion sensing exterior lighting to illuminate the area around all exterior doors, garages, and walkways to deter wildlife conflict incidents.
9. Plant native vegetation that does not require additional watering, instead of planting non-native ornamental plants and grass lawns that require irrigation and fertilization.
10. Fully enclose all crawl spaces and areas under ground level decks to prevent wildlife access.

Between the 2nd referral and public hearing, nearly all these recommendations have been added to the SUD in enforceable terms. However, concerns on the Seasonal Closure remain with CPW noting the proposed closure is not long enough and are requesting park closures between January 1 – July 1. The SUD proposes hard closure for January – April 1 to accommodate winter habitat and fawning which would cover the months of most inclement weather when animals may need to venture to areas with less snowpack. Although this is not meeting the full recommendation of CPW, staff anticipates an allowance of

year-round unlimited horses, dogs and firearms to be a more detrimental potential to wildlife than cyclists. Further, the park is proposed to be closed between twilight and sunrise which would leave the property entirely undisturbed for wildlife each night. Finally, CPW notes this property as a transitional property between Open Space parks to the southwest and northeast. This band also spans Shadow Mountain Drive which is significantly more impactful than the proposed use in terms of vehicular traffic, speed and frequency of disturbance. Local wildlife have been shown to overcome these circumstances to migrate, breed and flourish despite completely developed residential lots surrounding these areas. Staff supports a use with nightly and winter seasonal closures as preferred to residential continuous human disturbance to partially satisfy the recommendation of CPW.

11. NOTIFICATION

Notification of the proposed development was sent and posted in accordance with the Zoning Resolution. Please see the attached Notification Summary for more information.

12. POST HEARING REVIEW

If the Special Use is approved, the post hearing review shall be in accordance with the Zoning Resolution as follows:

The applicant shall have 28 days after Board of County Commissioner's approval to submit a 'clean' copy of the approved red-marked Special Use Document and pay the recordation fees. The Case Manager will have 7 days to review the submitted Special Use Document. If the revisions have been made in accordance with the approval conditions, Staff will affirm and record the Special Use Document, as appropriate. If the submitted documents are not in conformance with the approved red-marked Special Use Document, the red-marked Special Use Document shall be recorded.

13. SUBSEQUENT PROCESSES

If the Special Use is approved, prior to construction of any other buildings on the site a Site Development Plan (SDP) would be required. Building Permits would be required after SDP approval. During these processes, the SDP would be sent on referral to numerous internal and external agencies. The SDP and Building Permit applications are processes that will ensure compliance with all of the County's development regulations including, but not limited to building architecture, parking, illumination, landscaping, site grading and detention, wildfire mitigation, proof of water, proof of sanitation and other items.

SUMMARY OF STAFF ANALYSIS AND RECOMMENDATION

Staff's analysis concludes that the proposal does not meet one of the five Special Use Criteria. The Special Use proposal is not in general conformance with specific land use goals and policies outlined within the CMP, because the three factors for proposed uses out of conformance with the land use recommendation have not been adequately addressed. The proposal is compatible with the existing and allowed uses in the surrounding area. Potential negative impacts to the surrounding area have been adequately addressed using development standards in the SUD, infrastructure and services are adequate and available to support the proposed uses, and the proposed uses are not expected to result in significant impacts to the health, safety, and welfare of the residents and landowners in the surrounding area. Staff recommends DENIAL of the Special Use request because it is not in general conformance with the CMP.

FINDINGS:

Based on the analysis included in this report, staff concludes that the proposal has not satisfactorily addresses each of the criteria below which the Planning Commission may consider, as detailed in subsection 6 in this staff report.

1. The proposed Class III Recreational Facility land use is compatible with the existing and allowable single-family residential land uses in the surrounding area because large agricultural and parks for recreational activities are compatible with residential land uses.
2. The proposal is not in general conformance with the Comprehensive Master Plan (Plan). The proposal does not meet the Plan's land use recommendation of one residential dwelling unit per ten acres, and staff finds that the applicant has not satisfactorily addressed the three factors for non-conformance with the land use recommendation. All applicable sections of the Plan goals and policies have not been met.
3. The ability to mitigate the negative impacts of the proposed land use upon the surrounding area, including any geologic, sound, siting, illumination, use and transportation impacts, have been considered and mitigated with the restrictions set forth in the proposed Special Use Document. The requirements include restricted building footprints, large setback for buildings, maintenance roads, and chairlifts, and architectural requirements.
4. The subject property is proposed to be served by an individual onsite well and sanitation system. The Elk Creek Fire Protection District provides fire protection and first responder services. The Jefferson County Sheriff's Office provides law enforcement services. The public services are available and adequate to serve the proposed land use.
5. The proposed land use is not expected to result in significant impacts to the health, safety, and welfare of the residents and landowners in the surrounding area.

PLANNING COMMISSION ACTION:

The Planning Commission is charged with reviewing the request and staff report, receiving testimony and evidence on the application and recommending approval or denial of the request to the Board of County Commissioners.

COMMENTS PREPARED BY:

Dylan Monke

Dylan Monke

Planner

September 5, 2024

PROPOSED ZONING

Shadow Mountain Bike Park SPECIAL USE DOCUMENT

CASE NUMBER: 23-102980 RZ

SECTION 16, TOWNSHIP 6 SOUTH, RANGE 71 WEST, OF THE 6TH PRINCIPAL MERIDIAN
COUNTY OF JEFFERSON, STATE OF COLORADO

PAGE 1 OF 2

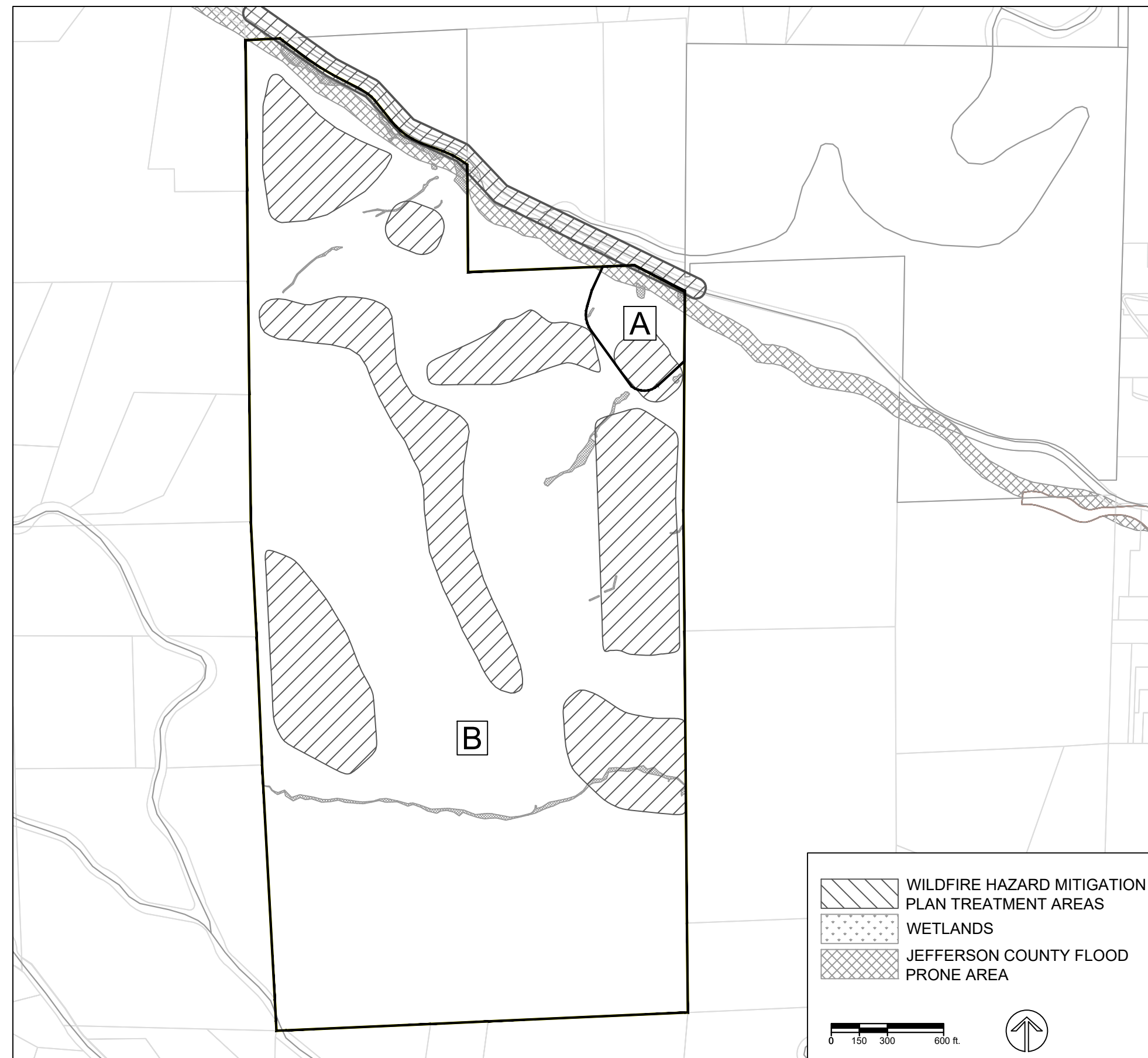

USE AREAS
SCALE 1"=600'

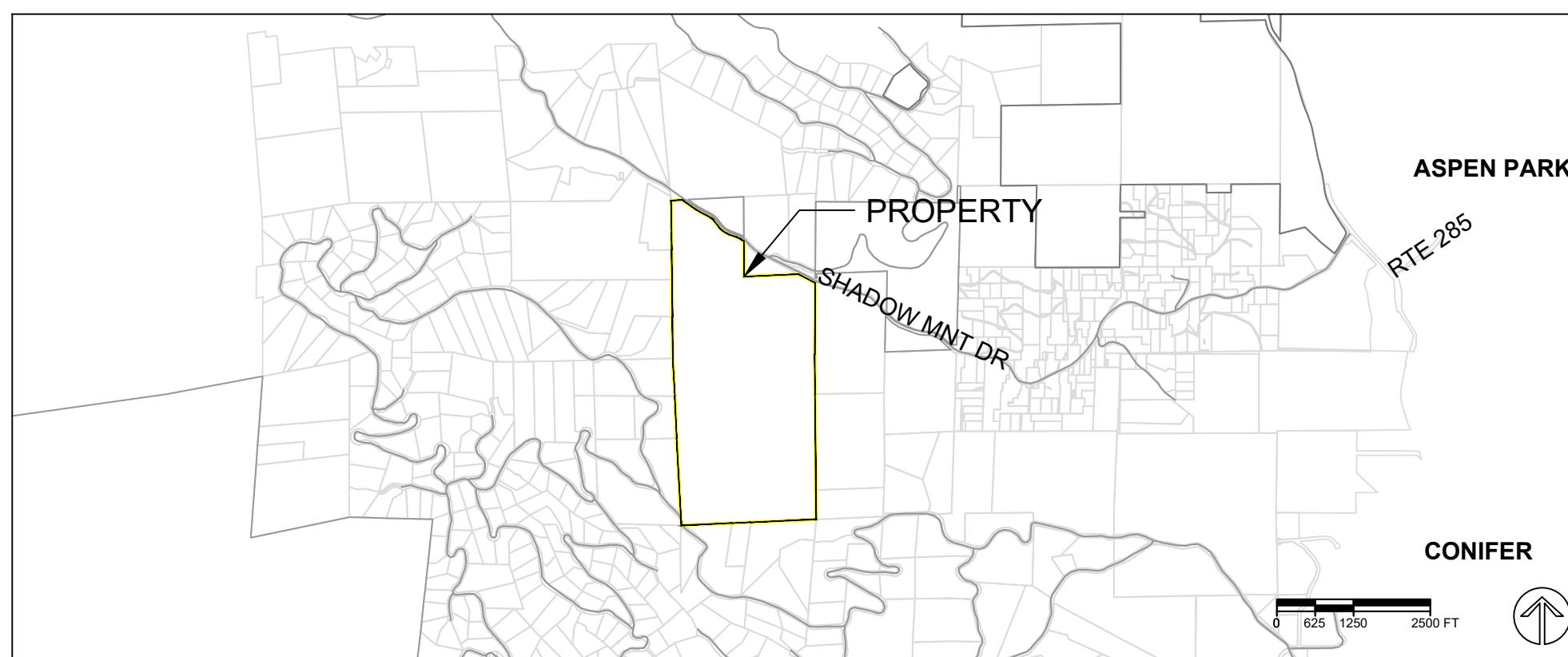

VICINITY MAP
SCALE 1"=2500'

LEGAL DESCRIPTION

All of the West Half (W1/2) of Section 16, Township 6 South, Range 71 West of the Sixth Principal Meridian, Jefferson County, Colorado.

SAVE AND EXCEPT, that portion thereof lying northerly of the south right of way line of Shadow Mountain Drive, as described in that document recorded in the records of the Jefferson County Clerk and Recorder at Reception No. F0829056 and that Parcel of Land described and depicted as Parcel 1 of the Plat of Exemption Sec. 16, T6S, R71W, 99015231EXP1 as recorded in the records of said Clerk and Recorder at Reception No. F1152563.

Said Parcel being subject to any existing easements and/or rights of way of whatsoever nature.

APPROVED FOR RECORDING:

This Special Use Document, titled Shadow Mountain Bike Park, was approved the _____ day of _____ 2024, by the Board of County Commissioners, of the County of Jefferson, State of Colorado and is approved for recording.

The owner of the property, at the time of approval was: Colorado State Land Board

By: Jefferson County Planning and Zoning Director

Signature: _____

Date: _____

CLERK AND RECORDER'S CERTIFICATE

Accepted for filing in the Office of the County Clerk and Recorder of Jefferson County at Golden, Colorado, this _____ day of _____, 20_____.

County Clerk and Recorder

Deputy Clerk

STANDARD FLEXIBILITY STATEMENT

The graphic drawing contained within this Official Development Plan is intended to depict general locations and illustrate concepts of the textual provisions of this Official Development Plan. During the plotting or Site Development Plan process the Planning and Zoning director may allow minor variations for the purpose of establishing:

- A. Final road alignments
- B. Final configuration of lot and tract sizes and shapes
- C. Final building envelopes
- D. Final access and parking locations
- E. Landscaping adjustments

APPLICABILITY STATEMENT

Except as expressly provided otherwise in this Official Development Plan, development of this property shall conform to the Jefferson County Zoning Resolution in effect at the time of platting, Site Development Plan, and building permit application.

OWNER'S CERTIFICATE

We, Colorado State Land Board, as owners of the land affected by this Planned Development, accept and approve all conditions set forth.

Abraham Medina
Recreation Program Manager
State Land Board

Accepted for filing in the Office of the County Clerk and Recorder of Jefferson County at Golden, Colorado, this ___ day of _____, 20_____.
County Clerk and Recorder _____
Deputy Clerk _____

DATE	ISSUED FOR	REVISION #

PREPARED BY:

SE GROUP, INC.
PO BOX 2729
FRISCO, CO 80443
www.segroup.com

Shadow Mountain Bike Park SPECIAL USE DOCUMENT

CASE NUMBER: 23-102980 RZ

SECTION 16, TOWNSHIP 6 SOUTH, RANGE 71 WEST, OF THE 6TH PRINCIPAL MERIDIAN
COUNTY OF JEFFERSON, STATE OF COLORADO

PAGE 2 OF 2

WRITTEN RESTRICTIONS

- A. **Intent.** The purpose of this Special Use is to permit a Class III Commercial Recreation Facility use for lift-assisted mountain biking and associated uses.
- B. **Written Restrictions.** All standards of the Agricultural Two Zone District (A-2) and other applicable sections of the Zoning Resolution shall apply to the Property, with the modifications contained herein. Capitalized terms not defined herein shall have the meanings ascribed to them in the Jefferson County Zoning Resolution.
 - 1. **Permitted Uses.**
 - a. **Primary Uses.**
 - i. Class III Commercial Recreation Facility, excepting therefrom any activity that involves the use of non-domestic animals and/or firearms
 - b. **Accessory Uses.**
 - i. Food and beverage vendors
 - 1. Maximums: Two food trucks and one grab and go vendor during hours of operation
 - 2. Food Truck Setbacks: 300 feet from N Property line and 100 feet from all other Property lines and located south of (behind) the Day Lodge
 - ii. Maintenance Facilities Setbacks: 50 feet from all Property lines
 - iii. Water Storage
 - 1. Maximum height above ground: 15 feet
 - 2. Maximum storage capacity: 202,000 gallons
 - 3. Setbacks: 50 feet from all Property lines
 - iv. Training Area Setbacks: 50 ft from all Property lines
 - 2. **Development Standards**
 - a. **Use Area A.** (6 acres)
 - i. Building Standards
 - 1. Max Building Square Footage: 15,000 feet
 - 2. Setbacks: 300 feet from N Property boundary, 100 feet from all other Property lines
 - ii. Maintenance Road(s) Setback: 50 feet from all Property lines
 - iii. Parking Setback: 50 feet from all Property lines
 - b. **Use Area B.** (229.3 acres)
 - i. Only permitted for accessory maintenance facilities
 - ii. Building Standards
 - 1. Max Building Square Footage: 5,000 square feet
 - 2. Setbacks: 300 feet from N Property boundary, 100 feet from all other Property lines
 - iii. Trail Standards
 - 1. Setbacks: 50 feet from all Property lines
 - 2. Trail clearing width: 30 feet maximum
 - iv. Chairlift Standards
 - 1. Max Chairlift Height: All Chairlift infrastructure (including terminals and towers) and accessory structures will not exceed 35 feet in height
 - 2. Setbacks: 150 feet from all Property lines
 - 3. Chairlift corridor clearing width: 40 to 60 feet in accordance with safety or chairlift commission regulations
 - 4. Chairlift terminals clearing: 200 feet maximum surrounding terminals
 - v. Maintenance Road(s) Setback: 50 feet from all Property lines
- 3. **Overlay Areas.**
 - a. **Wildfire Hazard Mitigation Overlay.**
 - i. Mitigation strategies as outlined in the Wildfire Hazard Mitigation Plan, attached hereto as Exhibit A, will be implemented as part of Defensible Space Permit requirements
 - b. **Wetlands Overlay.**
 - i. No building, parking area, nor Chairlift is permitted in the Wetlands Overlay
 - ii. In the event that Trail(s) cross the Wetlands Overlay, impacts must be avoided by bridging, raised platforms, or similar design
 - iii. One Access Road shall cross N Turkey Creek and abutting Wetlands Overlay once in Use Area A for vehicular access from Shadow Mountain Drive into the Property and one Maintenance Road shall cross the Wetlands Overlay at two points within Use Area B. Construction of the Access and Maintenance Roads will require the installation of three culverts, up to 50 ft in

- length, at each of these crossing points within the Wetlands Overlay. This work will be accomplished in accordance with State legislation and local authority guidance
- c. **Jefferson County Flood Prone Area Overlay**
 - i. No building, parking area, trail, nor Chairlift is permitted in the Flood Prone Area Overlay
- 4. **Lighting.**
 - a. No lighting is permitted in the Wetlands Overlay or Use Area B, except for lighting required in connection with the Chairlift
 - b. Lighting in Use Area A is permitted to be illuminated from one hour before to one hour after Guest Hours of Operation, except for security lighting, the use of which is not limited to certain hours
 - c. Lighting will be directed away from the Wetlands and Flood Prone Overlays
 - d. Building wall-mounted floodlights and rotating spotlights are prohibited
 - e. Light fixtures attached to any buildings shall not project above the fascia or roofline of such building, and shall not exceed 14 feet above the building foundation
- 5. **Signage.**
 - a. No more than one permanent sign is permitted per building
 - b. Signs will be no closer than 50 feet from all Property lines, except for Entry Feature Sign(s) which are permitted on the Property
 - c. Sign illumination is prohibited
 - d. Signs will match the architectural elements of the primary building and be integrated into the overall landscape and building design
- 6. **Sound.**
 - a. Sound levels shall adhere to maximum permissible noise levels for residential uses
 - b. Outdoor amplification is prohibited except for announcements and Special Event Permit occurrences
- 7. **Fencing.**
 - a. Only wildlife friendly fencing is permitted on the Property as defined by Colorado Parks and Wildlife (CPW)-recommended standards in the "Fencing With Wildlife in Mind" document or a similar document if CPW updates these standards
- 8. **Fires.**
 - a. Outdoor fires using wood or charcoal for fuel are prohibited
 - b. All outdoor fires of any type are prohibited in Use Area B
- 9. **Trash Management.**
 - a. Only wildlife-proof trash, recycling and composting containers are permitted to be used on the Property
 - b. Outside composting is prohibited
- 10. **Landscaping.**
 - a. Landscaping plans will integrate Wildfire Hazard Mitigation Plan and Vegetation Preservation Plan recommendations
 - b. The County landscaping regulations shall not apply except those standards for Parking Lot Areas as defined in Section 15 of the Jefferson County Zoning Resolution
- 11. **Architecture.**
 - a. Buildings shall be designed to remain in context with the landscape and structures surrounding the Property
 - b. Buildings and lift infrastructure will adhere to a color palette resembling the surrounding landscape including reds, browns, and blacks
 - c. The scenic character of the area will be protected through the use of low-impact materials and colors (e.g., indigenous construction materials, such as stone and wood, as well as low-reflective glass and roofing materials)
 - d. Any reflective materials (metal, glass, plastics, or other materials with smooth surfaces) shall be covered, painted, stained, chemically treated, etched, sandblasted, corrugated, or otherwise treated to reduce reflectivity in the landscape
 - e. Building roofs will be slanted and planar angled, preferably to align with the hillside
 - f. Flat roofs on buildings are prohibited
- 12. **Parking.**
 - a. The maximum number of parking spaces will not exceed 320 spaces
 - b. The minimum number of parking spaces shall adhere to a ratio of 1.0 space per 6 occupancy rating
 - c. Parking will only occur in designated parking spaces
 - d. Overnight visitor parking is prohibited; maintenance vehicles may be parked on the Property overnight, as necessary

- 13. **Wildlife**
 - a. Bird feeders are prohibited on the property between April 1st and the Thanksgiving holiday
 - b. Only round door knobs are permitted on all exterior doors on the property
 - c. All crawl spaces and areas under ground level decks shall be fully enclosed to prevent wildlife access
- 14. **Operations.**
 - a. **Guest Hours of Operation.** The Shadow Mountain Bike Park will be open to guests no earlier than sunrise and no later than sunset
 - b. **Seasonal Closure.** The Shadow Mountain Bike Park will be closed to guests from January 1 through April 1 (the "Seasonal Closure")
 - c. **Motorized Use.**
 - i. Motorized use is prohibited on trails
 - ii. Class I or II e-bikes are permitted on trails
 - d. **Guest Count.** The maximum number of guests visiting Shadow Mountain Bike Park in one day will not exceed 1,200 guests
- 15. **Definitions**
 - a. **Chairlift:** All infrastructure required for the operation, maintenance, and support of the lift structure, including but not limited to terminals, towers, lines, poles, chairs, electrical equipment, and other related components.
 - b. **Maintenance Facilities:** Operational, maintenance, and administrative services and facilities associated with the Class III Commercial Recreation Facility use.
 - c. **Trails:** Trails constructed for use by cyclists and, in some cases, individuals on foot or other non-motorized means of transportation.
 - d. **Food and Beverage Vendors:** Temporary food trucks outside of the Day Lodge or grab and go vendors within the Day Lodge, limited to vendors that do not require full kitchen space.
 - e. **Water Storage:** Permanent storage facilities for operational and fire flow uses, including above-ground reservoirs or ground storage/cisterns.
 - f. **Training Area:** An outdoor area for the purpose of training bike skills, which may include: structures, jumps, ramps, and obstacles, paths made of dirt, gravel, or other natural materials, and other mechanisms for the purpose of learning or practicing bike skills.
 - g. **Seasonal Closure:** An annual closure of Shadow Mountain Bike Park between January 1 and April 1 that does not permit guest access but does allow staff access and maintenance activities such as: construction of trails and infrastructure on an annual basis during development, trail maintenance, drainage maintenance, vehicle maintenance, facilities maintenance, or safety improvements.

DATE	ISSUED FOR	REVISION #

PREPARED BY:

SE GROUP, INC.
PO BOX 2729
FRISCO, CO 80443
www.segroup.com

EXHIBIT A

THE
Ember
Alliance



Shadow Mountain Bike Park Wildfire Mitigation Hazard Plan

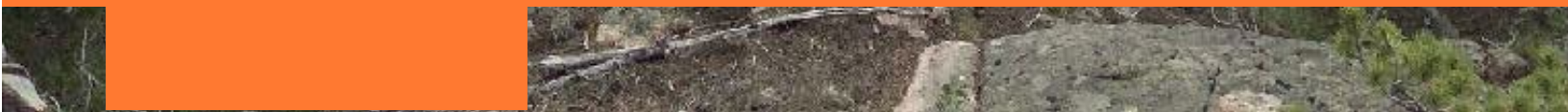

Prepared for:



Shadow Mountain Bike Park
FSBR LLC

- and -



SE Group
PO Box 2729
Frisco, CO 80443

Prepared by:



The Ember Alliance
PO Box 2084
Fort Collins, CO 80522

Table of Contents

1. Introduction	3
1.a. Site Visit.....	3
1.b. Management Area Maps and Desired Future Conditions	3
Management Area A.....	7
Management Area B.....	9
Management Area C.....	11
Management Area D.....	13
Management Area E.....	15
Management Area F.....	17
Management Area G.....	19
Management Area H.....	22
All Remaining Areas	22
2. References	23

1. Introduction

1.a. Site Visit

Staff at The Ember Alliance completed a site visit on September 20 and 21, 2023. A seasonal forestry crew walked the property assessing and delineating planned areas for mitigation and management. The visit also evaluated Shadow Mountain Drive between Highway 73 and the property, following the assessment guidelines in the Colorado State Forest Service (CSFS) Fuelbreak Guidelines document.

1.b. Management Area Maps and Desired Future Conditions

Eight management areas were delineated, along with descriptions of desired future conditions (DFCs) for each management area. These management areas and DFCs cover all the essential areas to treat to achieve SMBP’s goals for general wildfire mitigation and user safety. The remainder of the parcel does not have mitigation measures proposed because these areas were either not identified as having elevated wildfire risk or are intended to be monitored and

evaluated for treatment in future years. Additionally, leaving the remainder of the parcel as-is will help maintain the character of the surrounding landscape. Wildfires do not follow land ownership boundaries and therefore cross-boundary fuel treatments are always encouraged. For example, private landowners adjacent to the right-of-way can support evacuation safety by building upon right-of-way treatments and implementing guidelines in the CSFS fuelbreak guidance document on their adjoining property.

To define the DFCs, management objectives were first identified. This site is intended to be a recreational area within Jefferson County, so to be consistent with other recreational areas in Jefferson County, the management objectives for this site were defined as the same ones that Jefferson County Open Space uses in the [2022 Forest Health Plan](#). Ten objectives were identified, as follows:

1. Reduce risk of catastrophic wildfire
2. Reduce forest densities and canopy cover
3. Increase the presence, size, and diversity of forest openings
4. Restore and maintain a mosaic of ecosystems and vegetation cover across the landscape
5. Promote fine scale heterogeneity in tree spatial patterns
6. Protect and enhance old-growth features
7. Where appropriate, reestablish the use of prescribed fire as a management tool
8. Promote long-term ecosystem resilience to natural disturbance
9. Assist with ecosystem adaptation to climate change
10. Create aesthetically pleasing forest stands

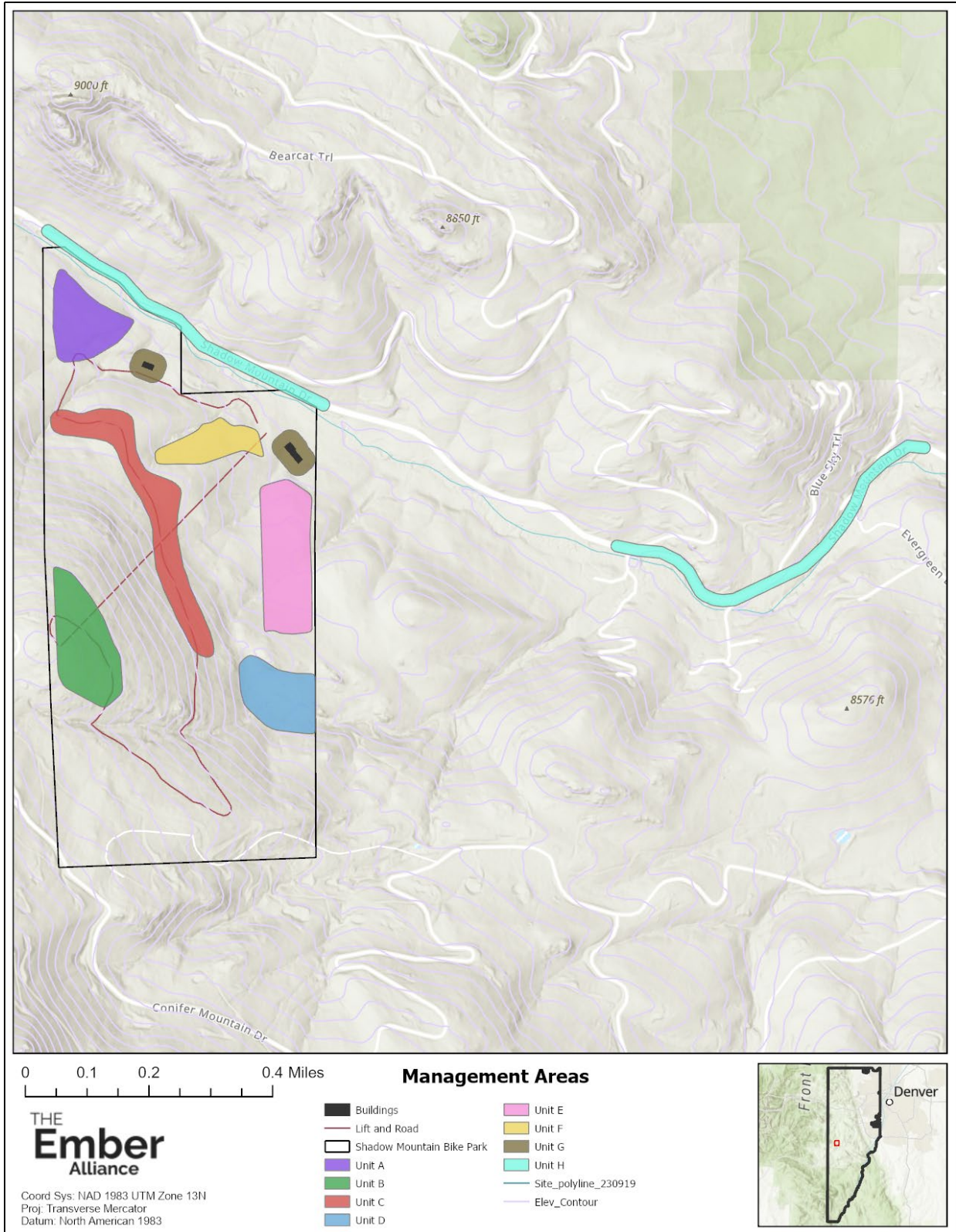

Figure 1. All Management Areas.

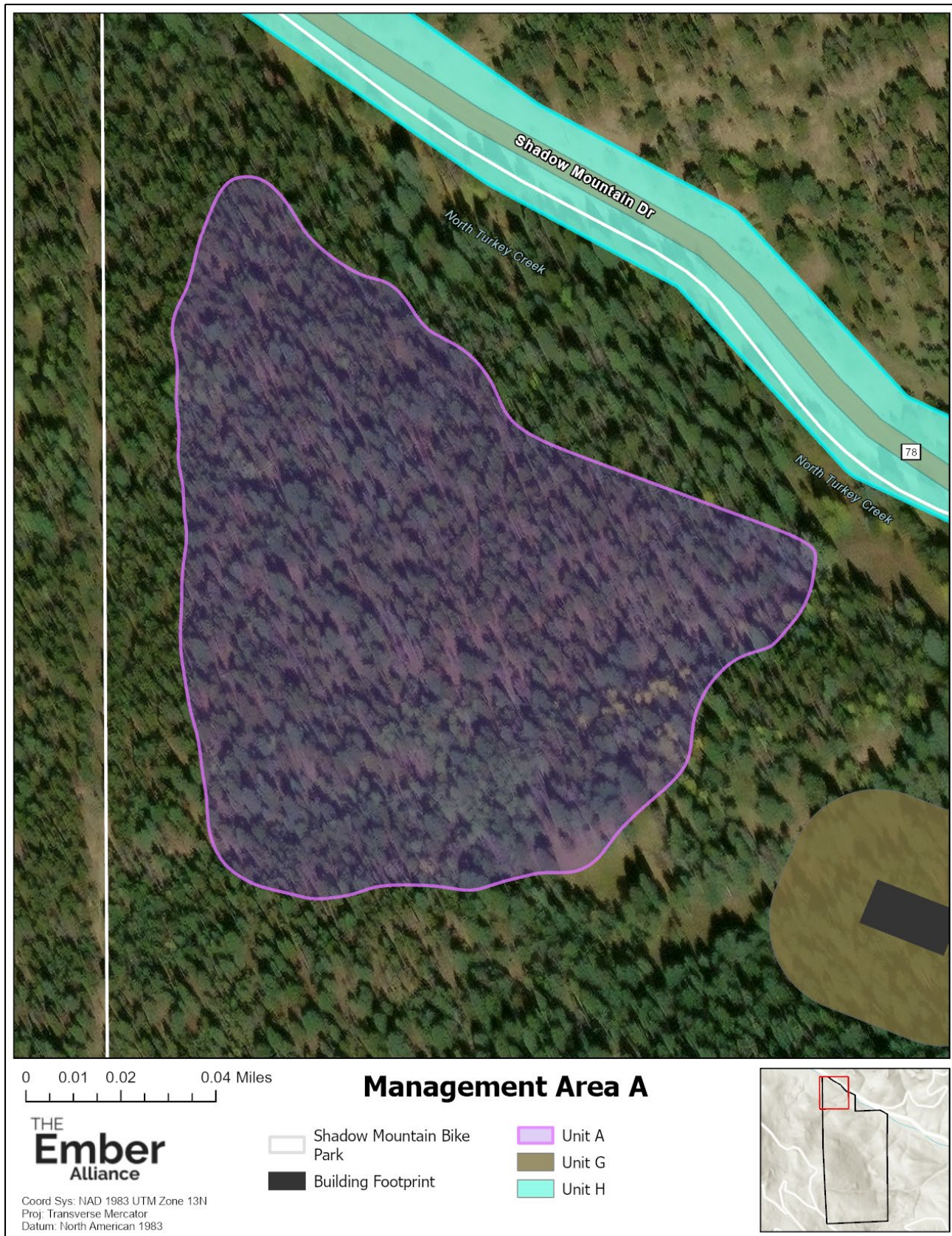

Figure 2. Management Area A.

Management Area A

Approximately 7.5 acres of mixed conifer and ponderosa pine forest.

Desired Future Conditions

Uneven-aged mixed conifer stands with occasional established ponderosa pine. Minimal ladder fuels are present, trees grouped with spacing between groups. Ponderosas have a wide spacing around their canopy. Occasional standing dead trees are retained as habitat trees.

Management Objectives Achieved: 1, 2, 3, 5, 6, 9, 10

Treatment

In Area A, all trees (excluding aspen) with a diameter at breast height (DBH) of 6 inches or under should be removed. All juniper and gamble oak should be removed. Occasional standing dead trees can be retained where they pose no risk to bikers.

Approximately 15-20% of trees with a DBH greater than 6 inches should be removed with an intent to isolate canopy groups. Retain all trees with a DBH greater than 20 inches, and favor removing smaller trees when possible. Favor retaining ponderosa pine to support climate adaptation within this ecosystem.

Limb (prune) all the remaining trees up to 10 feet from the ground. Work east as much as possible to preserve structures while maintaining a transition zone around the nearby private property/homes. Thin conifers as close as possible to the road and retain any aspen and willows near the river to support erosion control and stream health.

This area is best suited for selective hand thinning and chipping for slash management.

Treatment Return Interval

Evaluate the need for small diameter tree thinning and ladder fuel removal every 5 years.

Treatment re-entry needed to maintain forest health and historic conditions is estimated to be 8 to 23 years following the treatment. Regeneration can be dense and contribute to increased fire risk and intensity and should be actively managed and mitigated.

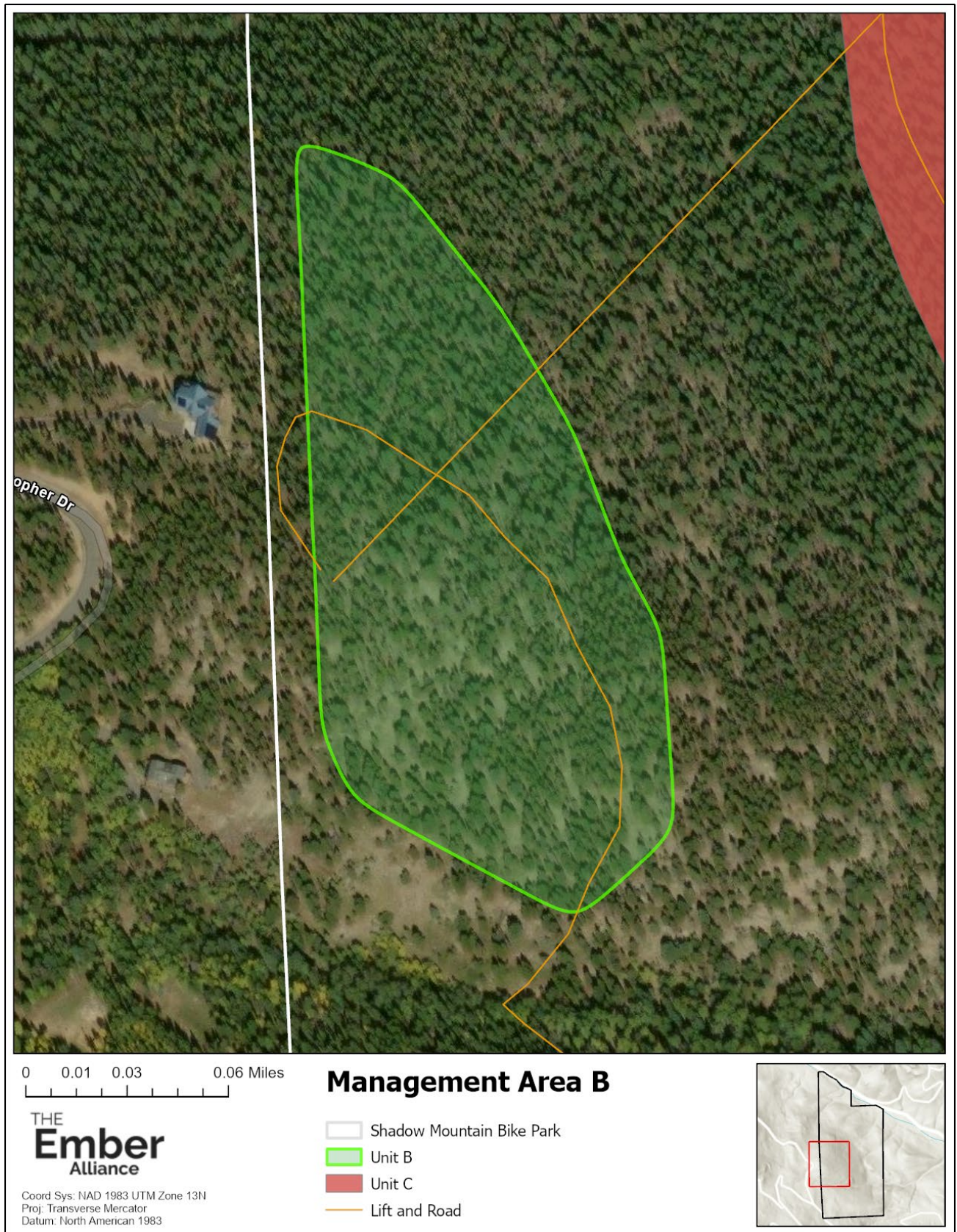

Figure 3. Management Area B.

Management Area B

Approximately 10.5 acres of mixed conifer and spruce-fir forest.

Desired Future Conditions

An uneven-aged mixed conifer/spruce-fir forest with groupings of trees. Conifer forests are maintained and moderately thinned to remove the most hazardous fuels but promote health and vigor of the remaining trees. Minimal ladder fuels are present, and there is enough open space to provide a view/outlook of the surrounding landscape. Trees in this area are in a stand that surrounds the “outlook” area. Trees are retained and managed to provide a visual buffer between the residences and the chairlift. Occasional standing dead trees are retained as habitat trees.

Management Objectives Achieved: 1, 2, 3, 5, 6, 7, 8, 10

Treatment

In Area B, all trees with a diameter at breast height (DBH) of 6 inches or under should be removed. All juniper and gamble oak should be removed. Occasional standing dead trees are retained where they pose no risk to bikers.

All trees with a DBH greater than 6 inches should be removed with the intent to isolate canopy groups. Retain all trees with a DBH greater than 20 inches, and favor removing smaller trees when possible.

Limb all the remaining trees up to 10 feet from the ground. Remove shrubs and ladder fuels under the trees. Maintain a transition zone to the private property.

This area is best suited for mechanical thinning and pile building for slash management.

Treatment Return Interval

Evaluate the need for small tree thinning and ladder fuel removal every 5 years. Treatment re-entry needed to maintain forest health and historic conditions is estimated to be 8 to 23 years following the treatment. Tree regeneration can be dense and contribute to increased fire risk and intensity and should be actively managed and mitigated.

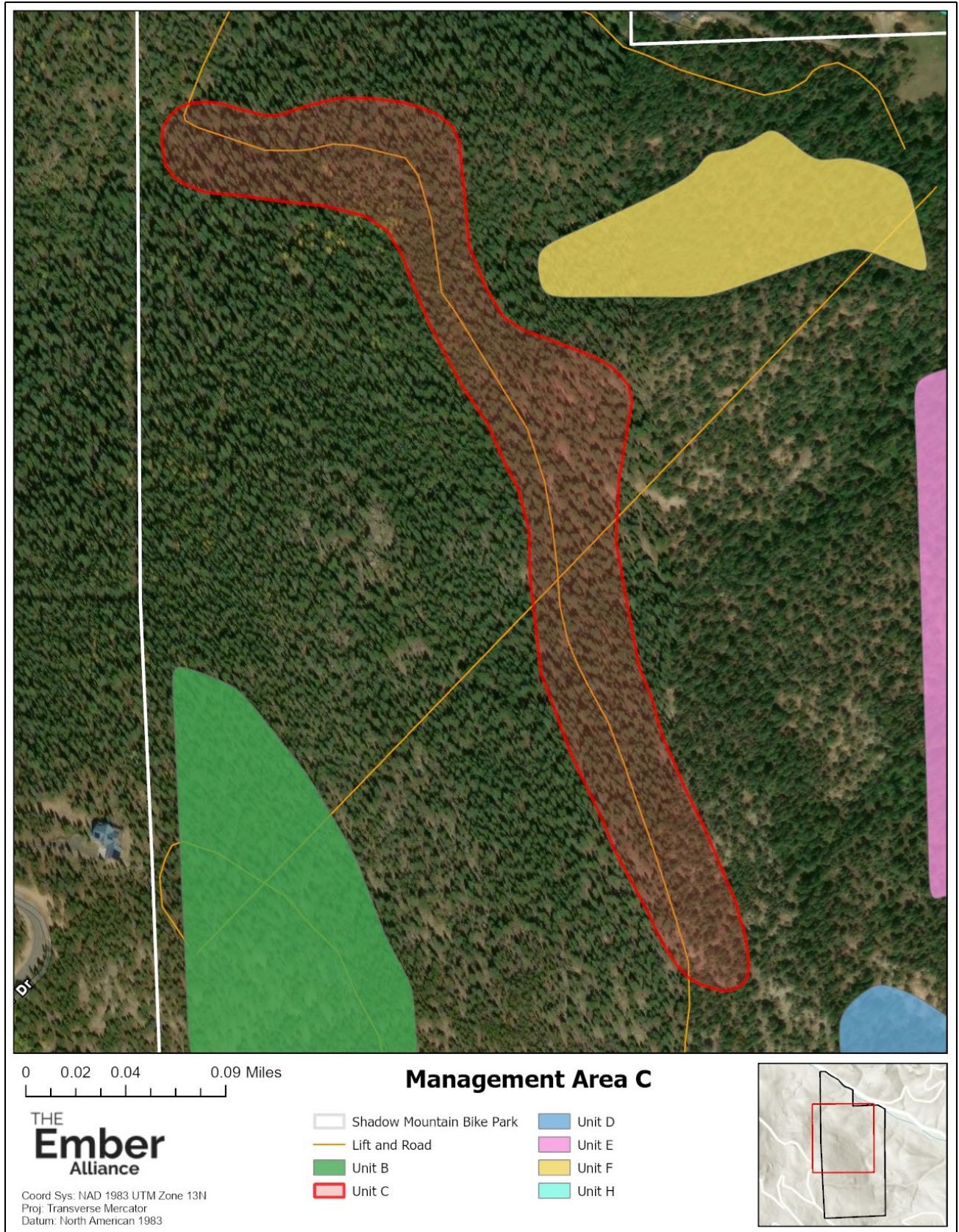

Figure 4. Management Area C.

Management Area C

Approximately 14 acres of mixed conifer, spruce-fir, and ponderosa pine forest.

Desired Future Conditions

A fuel break along the maintenance road/base of the steep slope of the mixed conifer forest. Minimal ladder fuels are present, with wide spacing between tree crowns/groupings of tree crowns. Standing dead trees are not retained.

Management Objectives Achieved: 1, 2, 3, 5, 6, 8, 10

Treatment

In Area C, all trees (excluding aspen) with a diameter at breast height (DBH) of 6 inches or under should be removed. All juniper and gamble oak should be removed.

Approximately 15-20% of trees with a DBH greater than 6 inches should be removed with an intent to isolate canopy groups. Retain all trees with a DBH greater than 20 inches, and favor removing smaller trees when possible.

Limb all the remaining trees up to 10 feet from the ground. Remove ladder fuels/shrubs under the trees.

This area is best suited for selective hand thinning and chipping for slash management.

Treatment Return Interval

Evaluate the need for small tree thinning and ladder fuel removal every 5 years. Treatment re-entry needed to maintain forest health and historic conditions is estimated to be 8 to 23 years following the treatment. Tree regeneration can be dense and contribute to increased fire risk and intensity and should be actively managed and mitigated.

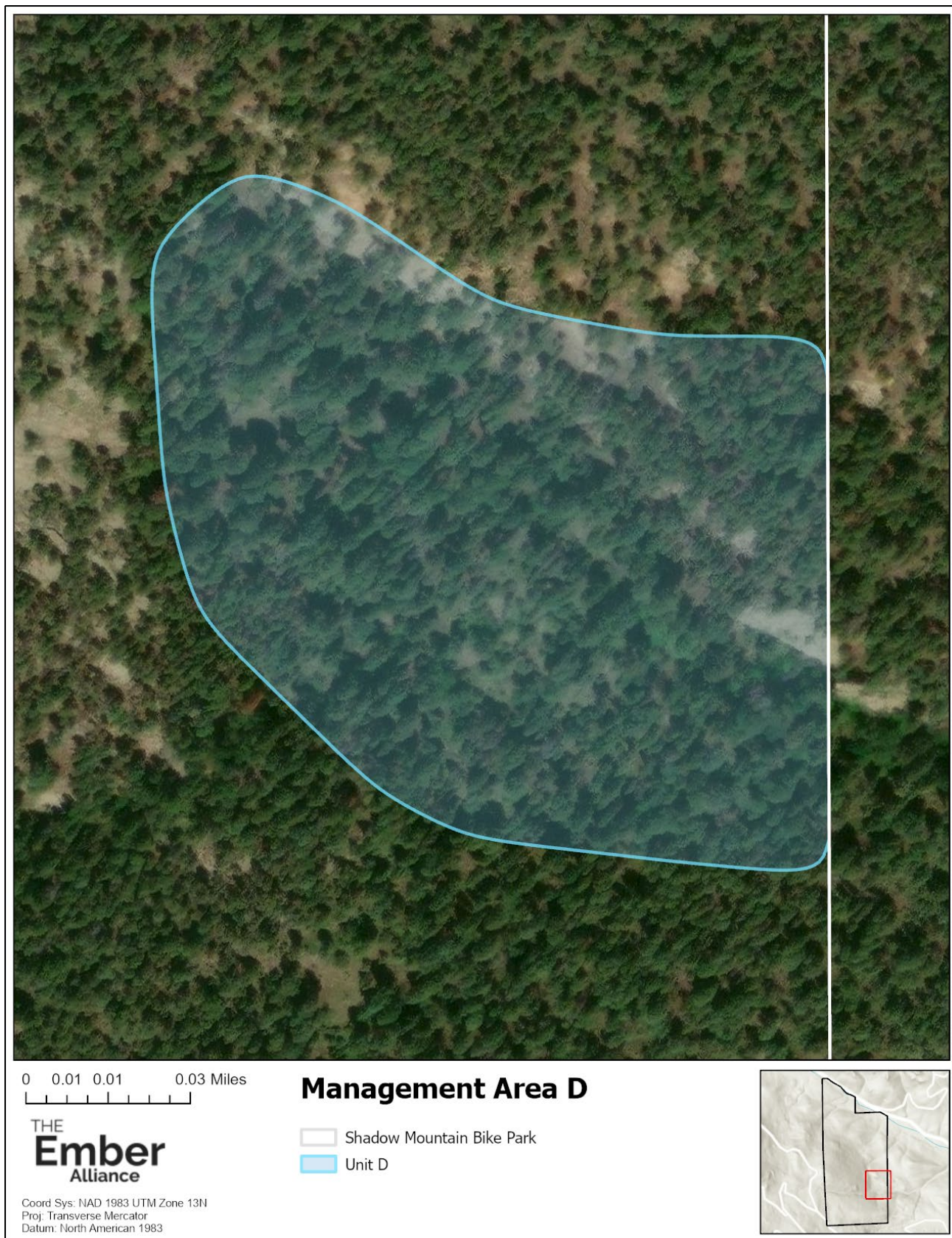

Figure 5. Management Area D.

Management Area D

Approximately 7.5 acres of lodgepole pine forest with some fir.

Desired Future Conditions

Mosaic stands of lodgepole pine. Each stand is even-aged but there is age diversity between the stands. Patch cuts mimic historic fire in this forest type, which would replace entire stands with each fire event. To protect the aesthetic and habitat value of the lodgepole pine area, smaller patch cuts are completed, rather than larger cuts.

Management Objectives Achieved: 1, 2, 3, 4, 5, 6, 8, 9, 10

Treatment

In Area D, patch cut in 3-acre sections, focusing along the west flank until the lodgepole stand gets too steep to cut. Patch cuts remove all sizes and species of trees except aspen, which are retained. Occasional standing dead trees may be retained, if present. The steepness of the site may limit the work that a crew can complete.

This area is best suited for hand crew cutting and pile building/burning for slash management.

Treatment Return Interval

After the initial 3-acre patch cut is completed, that stand is permitted to regenerate without thinning for at least 75 years (the lower end of their historic fire return interval). A second or third entry for patch cuts in other sections of this management area can be completed in the decades following the initial cut. Age diversity between the patch cuts is important as it creates habitat diversity and a mosaic landscape that is more resilient to wildfire. Stands should not frequently reach an average age beyond 300 years, which is the upper end of their fire return interval.

If the land managers have the resources, additional 3- to 6-acre patch cuts can be completed with the same objectives and DFCs in the southwest corner of the property. The north-facing hillside on the very south side of the property can be treated for additional fuels mitigation and habitat diversity.

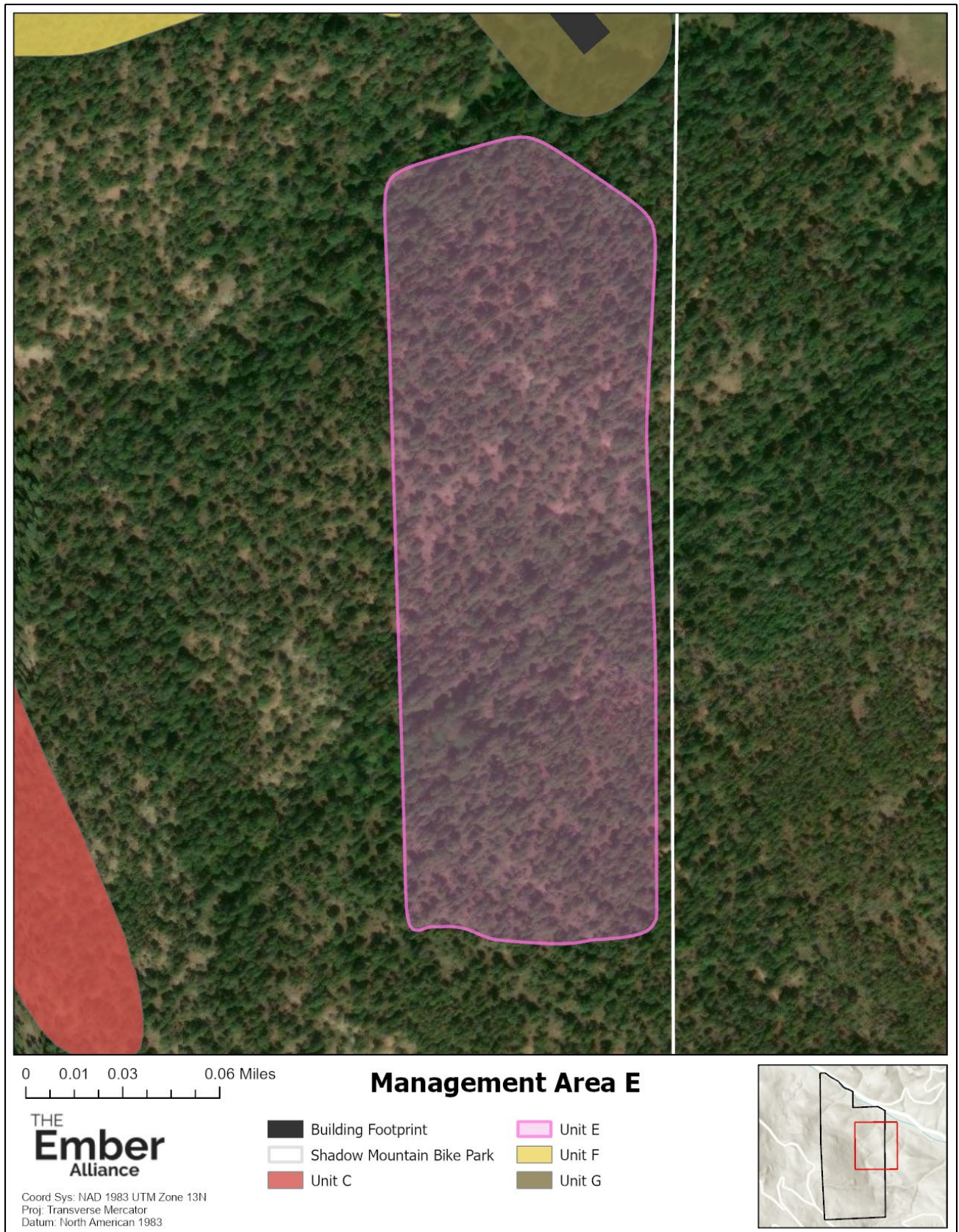

Figure 6. Management Area E.

Management Area E

Approximately 12 acres of mixed conifer forest with aspen.

Desired Future Conditions

An uneven-aged mixed conifer forest with increasingly large aspen stands. Conifer forests are maintained and moderately thinned to remove the most hazardous fuels but promote health and vigor of the remaining trees. Aspen is favored and allowed to grow freely, becoming old growth in time. Small forest openings are present between aspen and conifer, and between groupings of conifers. Minimal ladder fuels are present in the coniferous areas and occasional standing dead trees are retained as habitat trees.

Management Objectives Achieved: 1, 2, 3, 4, 5, 6, 8, 9, 10

Treatment

In Area E, all trees (excluding aspen) with a diameter at breast height (DBH) of 6 inches or under should be removed. All juniper and gamble oak should be removed. Occasional standing dead trees are retained where they pose no risk to bikers.

Approximately 15-20% of trees with a DBH greater than 6 inches should be removed with an intent to isolate canopy groups, cutting smaller trees when possible.

Limb all the remaining trees up to 10 feet from the ground. Remove shrubs and ladder fuels under trees.

This area is best suited for selective hand thinning and pile building/burning for slash management.

Treatment Return Interval

Evaluate the need for small tree thinning and ladder fuel removal every 5 years. Treatment re-entry needed to maintain forest health and historic conditions is estimated to be 8 to 23 years following the treatment. Tree regeneration can be dense and contribute to increased fire risk and intensity and should be actively managed and mitigated.

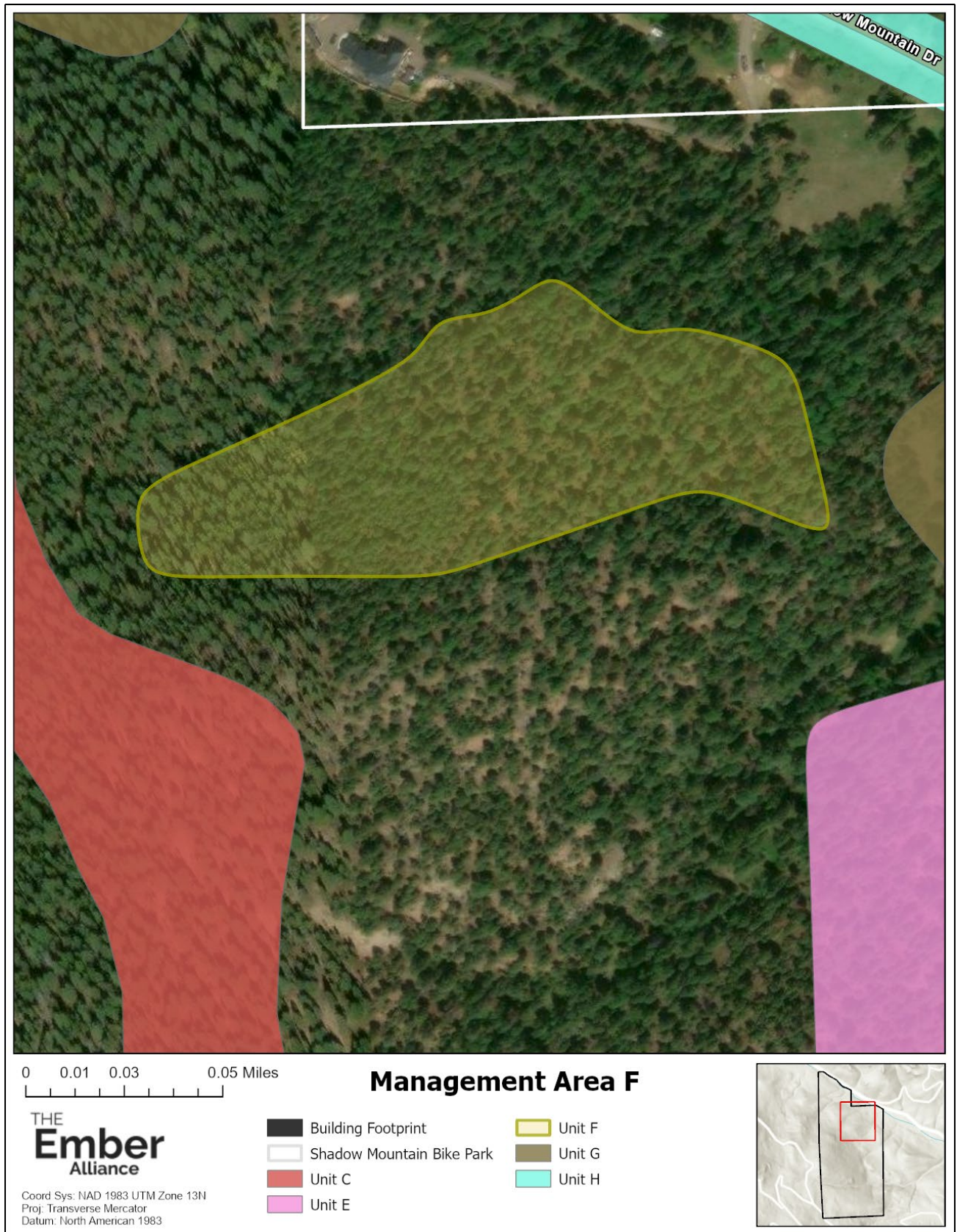

Figure 7. Management Area F.

Management Area F

Approximately 5 acres of mixed conifer forest with aspen.

Desired Future Conditions

An uneven-aged mixed conifer forest with increasingly large aspen stands. Conifer forests are maintained and thinned to remove the most hazardous fuels but promote health and vigor of the remaining trees. Aspen is favored and allowed to grow freely, becoming old growth in time. Small forest openings are present between aspen and conifer, and between groupings of conifers. Minimal ladder fuels are present in the coniferous areas and occasional standing dead trees are retained as habitat trees.

Management Objectives Achieved: 1, 2, 3, 4, 5, 6, 8, 9, 10

Treatment

In Area F, all trees (excluding aspen) with a diameter at breast height (DBH) of 6 inches or under should be removed. All juniper and gamble oak should be removed.

Approximately 15-20% of trees with a DBH greater than 6 inches should be removed with an intent to isolate canopy groups. Retain all trees with a DBH greater than 20 inches, and favor removing smaller trees when possible.

Limb all the remaining trees up to 10 feet from the ground. This area is very dense with lots of saplings. Maintain a transition zone around the nearby private property/homes.

This area is best suited for selective hand thinning and chipping and/or pile building for slash management.

Treatment Return Interval

Evaluate the need for small tree thinning and ladder fuel removal every 5 years. Treatment re-entry needed to maintain forest health and historic conditions is estimated to be 8 to 23 years following the treatment. Tree regeneration can be dense and contribute to increased fire risk and intensity and should be actively managed and mitigated.

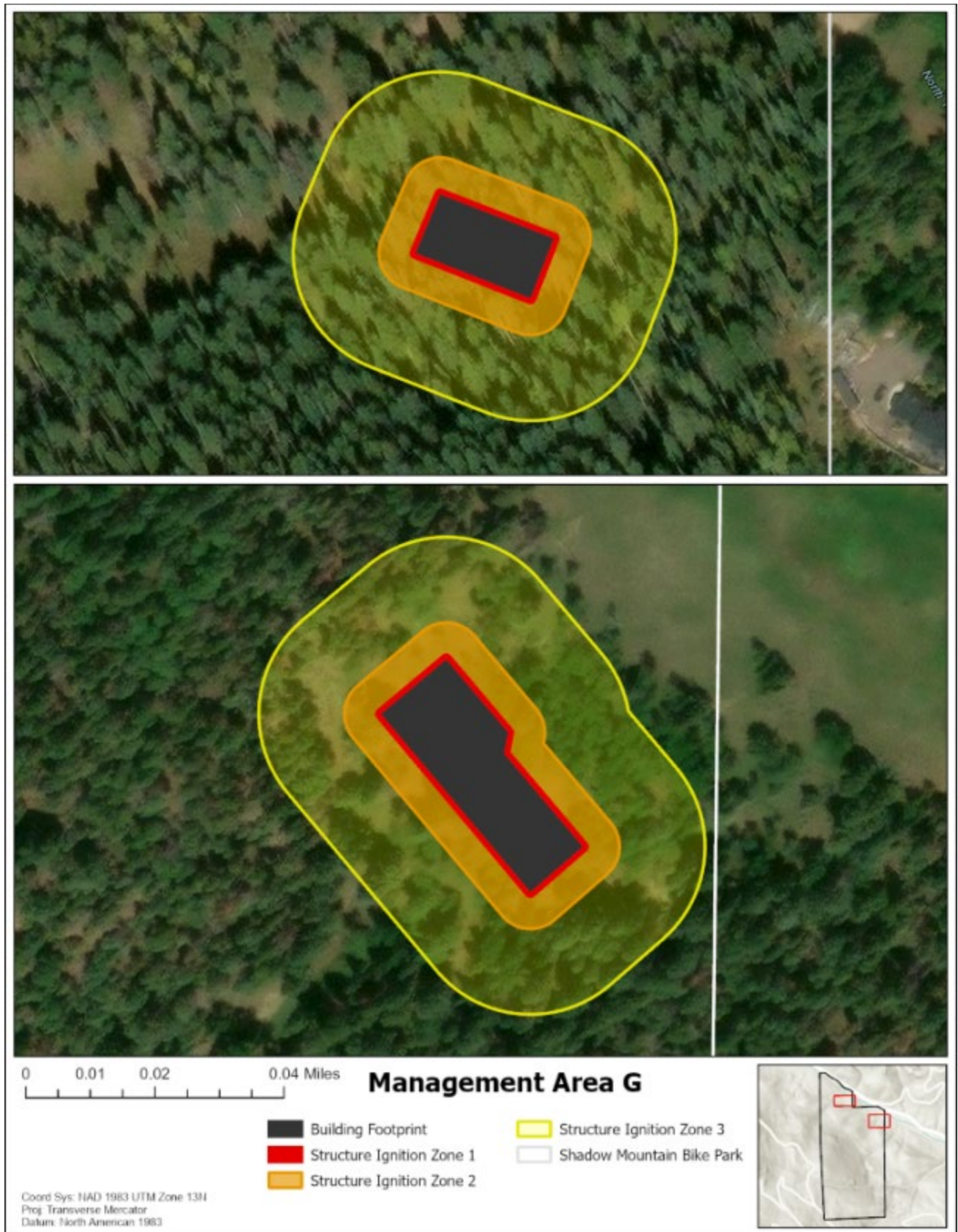

Figure 8. Management Area G.

Management Area G

Approximately 3.5 acres of mixed conifer forest with aspen.

Desired Future Conditions

Structures have home hardening measures taken to be ignition resistant. No vegetation within 5 feet of the structures. Minimal, potentially irrigated vegetation within 30 feet of the structures. Minimal vegetation with wide spacing and no ladder fuels within 100 feet of the structure.

Management Objectives Achieved: 1, 2, 3, 4, 5, 10

Treatment

Zone 1: From 0-5 feet from the edge of the buildings, install concrete, gravel, or another non-flammable groundcover.

Zone 2: From 5-30 feet, there should be no more than 20 trees total left within this zone around the maintenance facility and no more than 30 around the lodge (assuming an average tree crown spread of 30 feet). We recommend aiming for approximately half that number to err on the side of caution, leaving no more than 10 and 15 trees, respectively. If there are aspens, those should be selected to remain over any other species. All trees should have a minimum of 10 feet of spacing between the crowns. If trees are planted following the building construction, include the anticipated crown diameter in this plan. Remove any dead, dying, or diseased trees.

Mow all grasses regularly to keep the height no more than 4 inches. Irrigation is recommended but not necessary, due to water constraints and the desire for a natural aesthetic.

All remaining trees should be limbed (pruned) to a height of 10 feet. This means the distance from the ground to the bottom of the lowest part of the lowest hanging branch.

All juniper and gamble oak should be removed. Any other remaining shrubs, such as mountain mahogany or chokecherry, can remain if they are not under trees or tree canopies. Shrubs should be isolated and not be allowed to grow in groups or continuous clusters.

Zone 3: From 30-100 feet from the end of the structures, there should be no more than 36 trees total left within this zone around the maintenance facility and no more than 48 around the lodge (assuming an average tree crown spread of 30 feet). We recommend aiming for approximately half that number to err on the side of caution, leaving no more than 18 and 24 trees, respectively. If there are aspens, those should be selected to remain over any other species. All trees should have a minimum of 10 feet of spacing between the crowns. Remove any dead, dying, or diseased trees.

The remaining trees should be limbed to a height of 10 feet. This means the distance from the ground to the bottom of the lowest part of the lowest hanging branch. Remove any shrubs that are under tree canopies.

This area is suitable for mechanical or hand thinning. Any and all slash, woody debris, or other flammable material should be removed entirely from these zones. They can be hauled off site or masticated and spread outside the zones.

Treatment Return Interval

Annual maintenance of each of these areas is required.

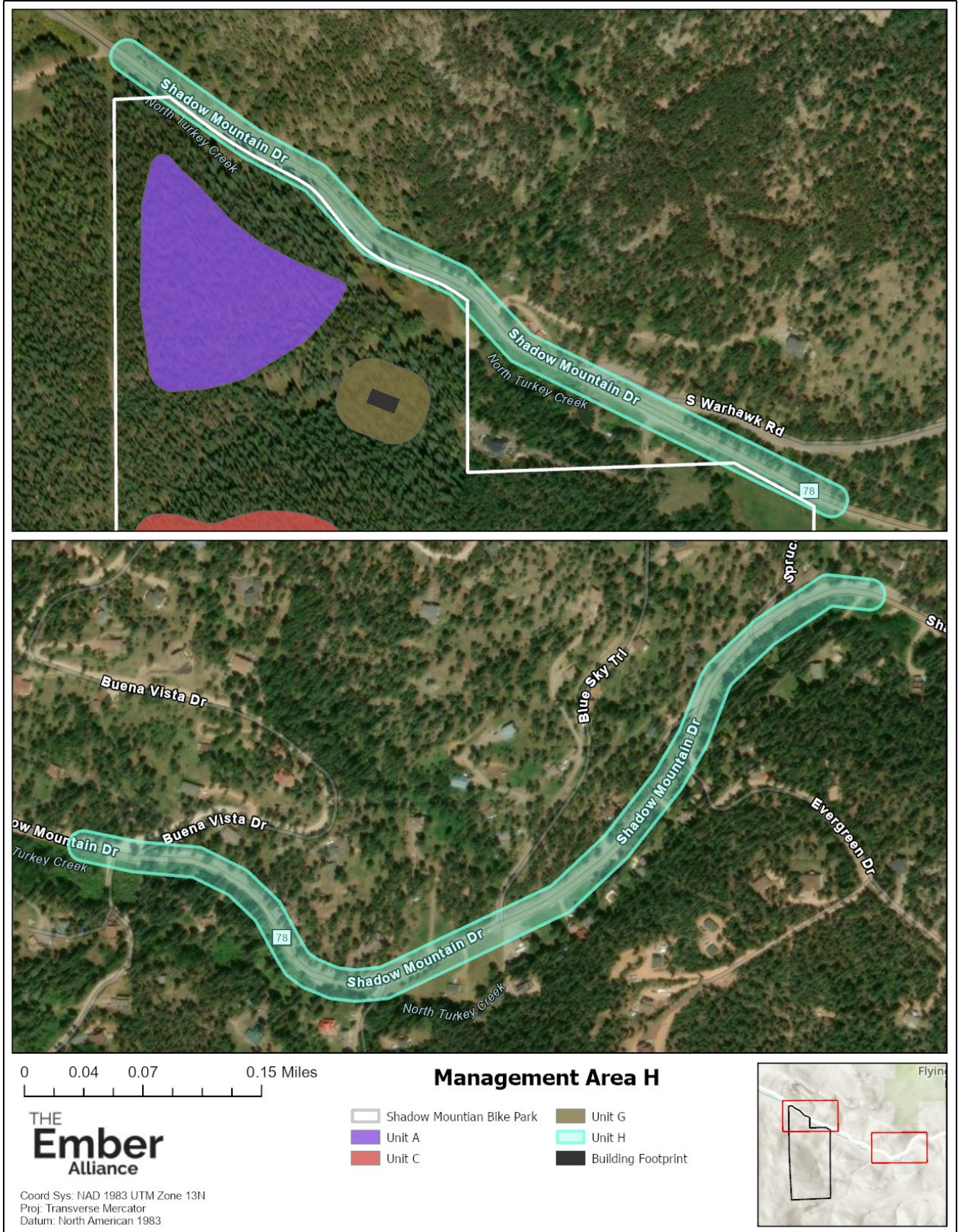

Figure 9. Management Area H.

Management Area H

Approximately 1.25 miles of road. The crowning potential in this area ranges from 3-9, designating it as an area in need of treatment and mitigation.

Desired Future Conditions

The road has space to either side of the lanes that is open enough to keep the flame length down to 8 feet or less. Evacuating residents and incoming firefighters have adequate space to drive and turn around engines without endangering their passengers.

Crowning potential, when assessed to the same CSFS Fuelbreak Guideline standards, should be a 3 or below following the treatment.

Management Objectives Achieved: 1, 2, 3, 4, 5, 6, 8

Treatment

In Area H, remove all trees (excluding aspen) within 15 feet of the edge of the road within the county right-of-way. Beyond that in the right-of-way, thin trees according to the CSFS Fuelbreak Guidelines document along the identified portions of Shadow Mountain Drive. This involves creating 10 feet of space between crowns and removing ladder fuels under and between the trees. Favor retaining larger and older trees, as well as retaining aspen or other riparian species, where they are present. The treatment recommendation is that the fuelbreak is mitigated as far from the road as is feasible using bike park-owned land and county right-of-way easements.

This area is best suited for selective hand thinning and/or use of a roadside masticator head and chipping for slash management.

Treatment Return Interval

Tree regeneration in opened stands such as initial fuelbreak cuts can be dense and contribute to increased fire risk and intensity. This should be actively managed and mitigated over time through follow up treatments. Evaluate the need for thinning, regeneration removal, and ladder fuel removal every 3 years. This is a shorter evaluation time than other management areas due to the life safety aspect of this treatment.

All Remaining Areas

No mitigation action is recommended for the remaining forest areas. We recommend that they be monitored and managed for forest health and that the mitigation plan be revisited in approximately 15 years.

Citation: The Ember Alliance. 2023. *Shadow Mountain Bike Park Wildfire Mitigation Hazard Plan*. Fort Collins, CO.

2. References

Colorado Forest Restoration Institute. 2021. Fires behavior differently in different forest types [WWW Document]. Colorado State University, Colorado Forest Restoration Institute. <https://cfri.colostate.edu/wp-content/uploads/sites/22/2021/01/FireEd-Infographic-Web-Print-1.pdf>

Colorado Forest Restoration Institute. 2022. 2022 Jefferson County Open Space Forest Health Plan. Colorado State University, Colorado Forest Restoration Institute. <https://www.jeffco.us/DocumentCenter/View/33433/JCOS-Forest-Health-Plan-DRAFT>

Colorado State Forest Service 2021. The home ignition zone: A guide to preparing your home for wildfire and creating defensible space. Colorado State University, Colorado State Forest Service. Fort Collins, CO. <https://csfs.colostate.edu/wp-content/uploads/2021/04/2021-CSFS-HIZGuide-Web.pdf>

Dennis, F.C. 2005. Fuelbreak guidelines for forested subdivisions and communities. Colorado State University, Colorado State Forest Service, Fort Collins, CO.

Hunter, M.E.; Shepperd, W.D.; Lentile, J.E.; Lundquist, J.E.; Andreu, M.G.; Butler, J.L.; Smith, F.W. 2007. A comprehensive guide to fuels treatment practices for ponderosa pine in the Black Hills, Colorado Front Range, and Southwest. Gen. Tech. Rep. RMRS-GTR-198. Fort Collins, CO: U.S. Department of Agriculture, Forest Service, Rocky Mountain Research Station. 93 p. https://www.firescience.gov/projects/05-S-03/project/05-S-03_05_S_03_Deliverable_02.pdf

U.S. Forest Service. 2012. Spruce-fir Forest Desired Condition. https://www.fs.usda.gov/Internet/FSE_DOCUMENTS/stelprdb5409830.pdf

MAPS

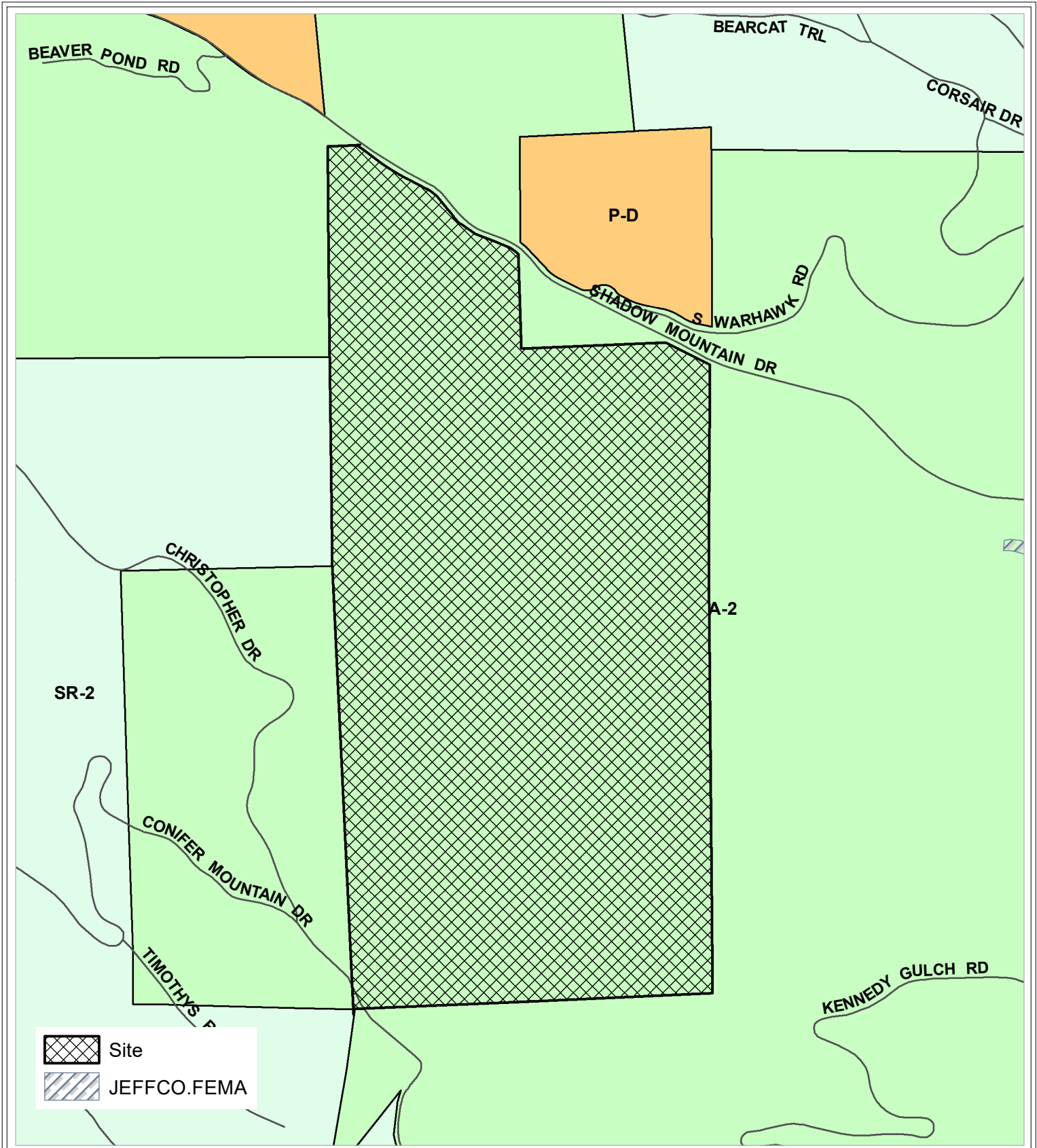

Case Number: 23-102980RZ
Location: Section 16, T6S, R71W



This product has been developed for internal use only. The Planning and Zoning Division makes no warranties or guarantees, either expressed or implied, as to the completeness, accuracy or correctness of such products, nor accepts any liability arising from any incorrect, incomplete or misleading information contained therein.



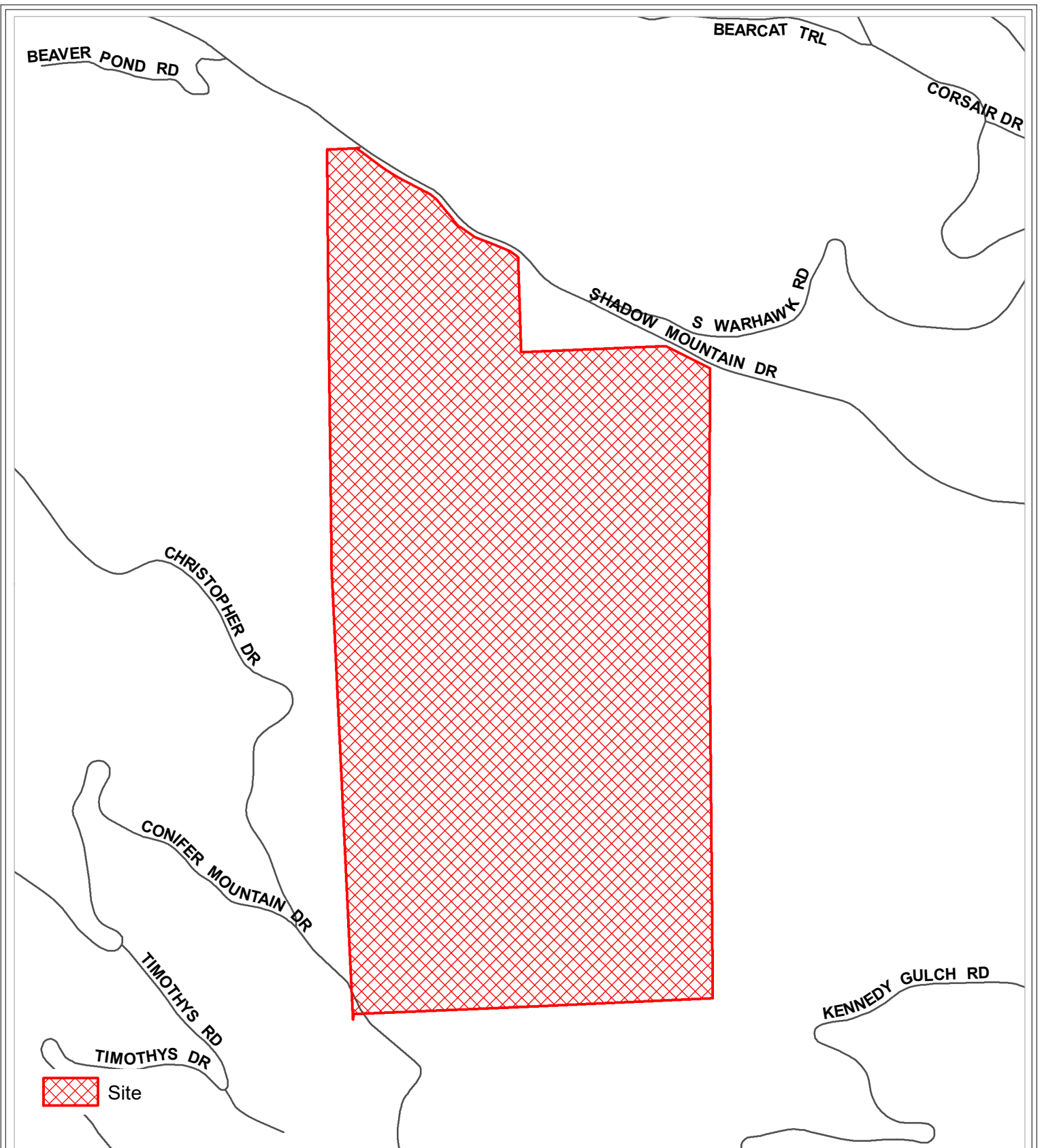

Case Number: 23-102980RZ
Location: Section 16, T6S, R71W



JEFFERSON
 COUNTY COLORADO

This product has been developed for internal use only. The Planning and Zoning Division makes no warranties or guarantees, either expressed or implied, as to the completeness, accuracy or correctness of such products, nor accepts any liability arising from any incorrect, incomplete or misleading information contained therein.

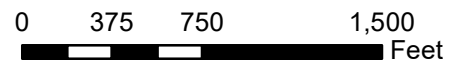

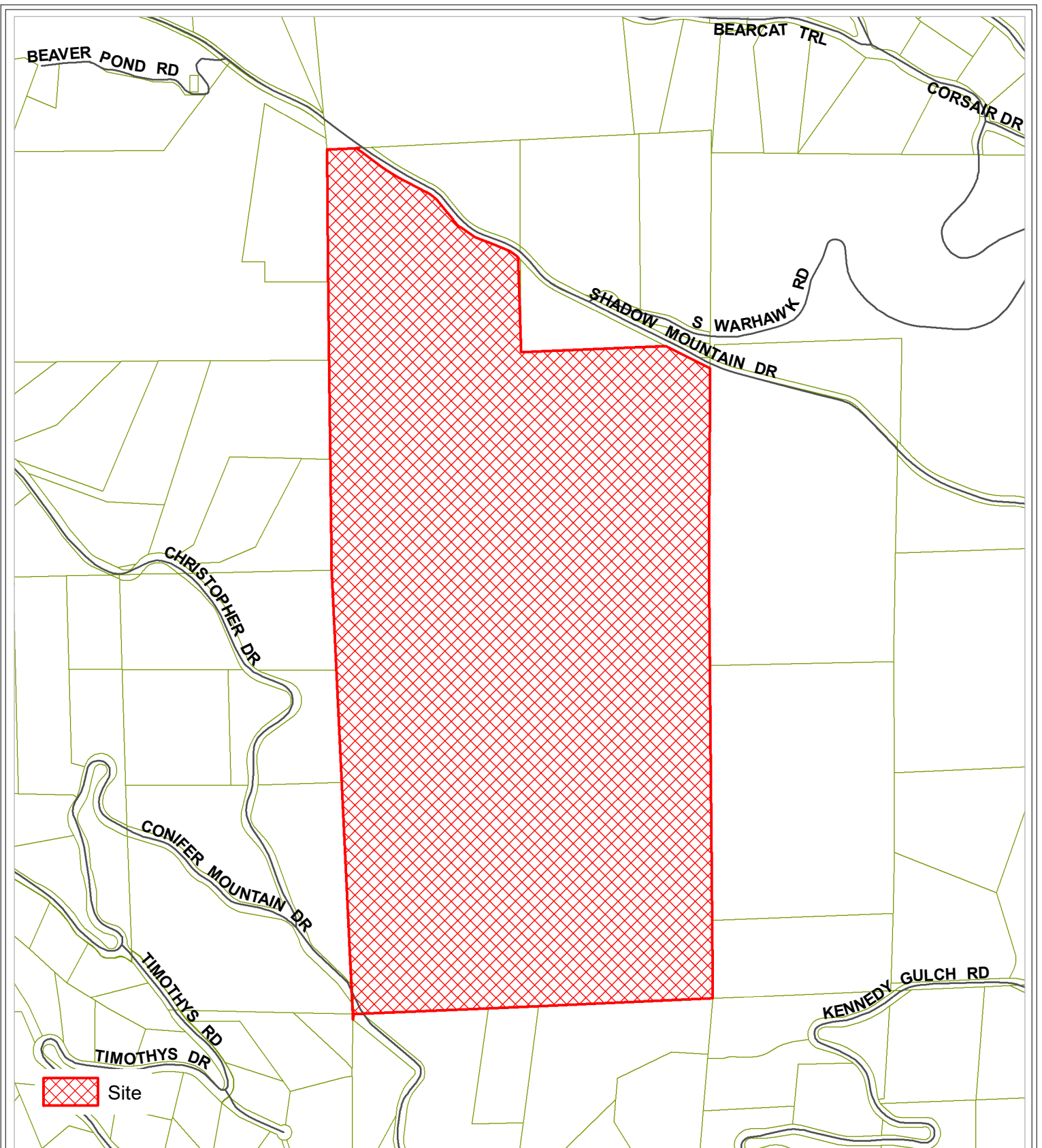

Case Number: 23-102980RZ

Location: Section 16, T6S, R71W



JEFFERSON
COUNTY COLORADO

This product has been developed for internal use only. The Planning and Zoning Division makes no warranties or guarantees, either expressed or implied, as to the completeness, accuracy or correctness of such products, nor accepts any liability arising from any incorrect, incomplete or misleading information contained therein.

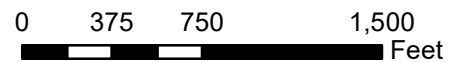

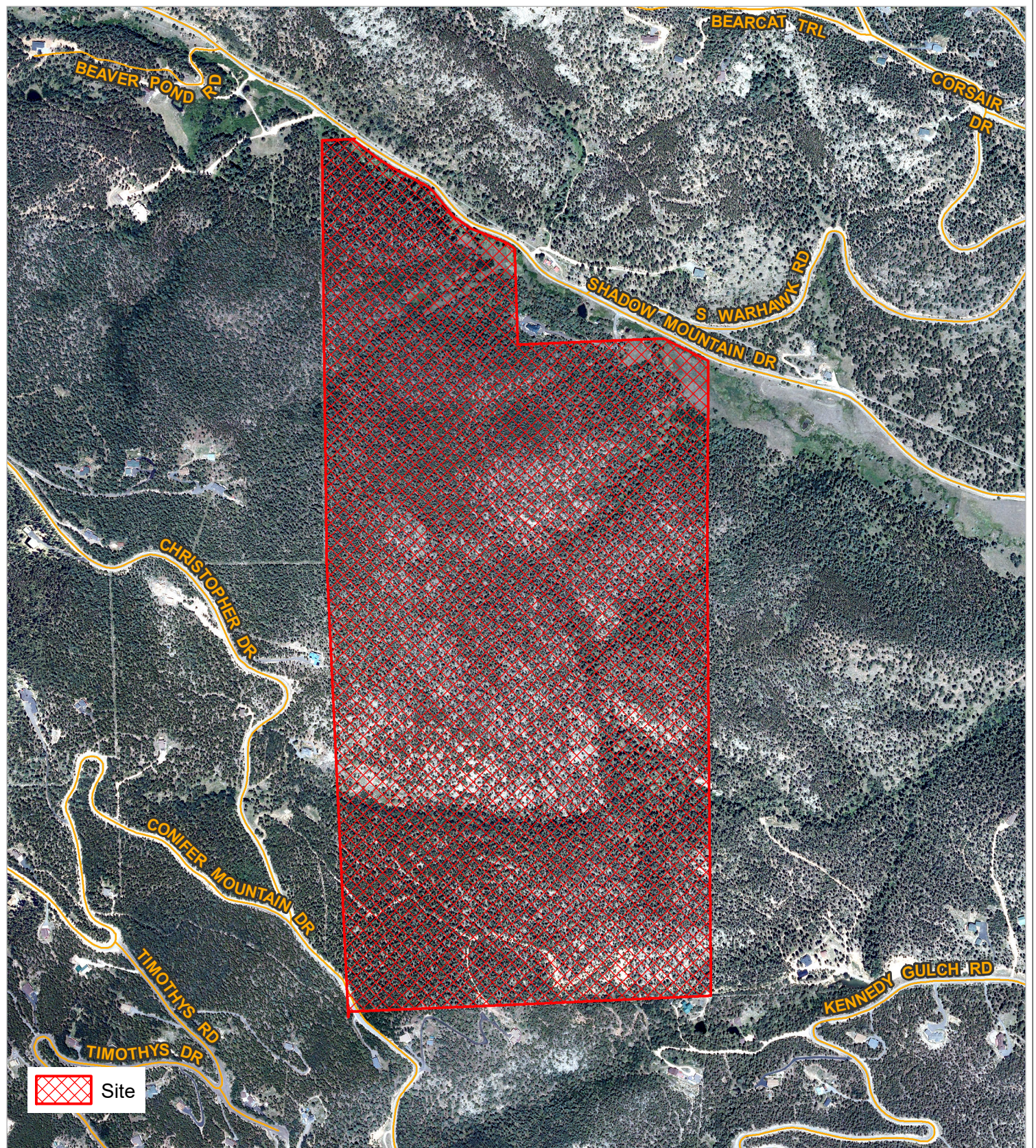

Case Number: 23-102980RZ
Location: Section 16, T6S, R71W



JEFFERSON
 COUNTY COLORADO

This product has been developed for internal use only. The Planning and Zoning Division makes no warranties or guarantees, either expressed or implied, as to the completeness, accuracy or correctness of such products, nor accepts any liability arising from any incorrect, incomplete or misleading information contained therein.

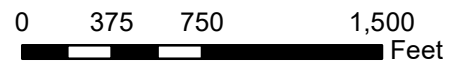

Case No. 23-102980RZ

Legal Description

Street Location of Property Shadow Mountain Drive

Is there an existing structure at this address?

Yes _____ No X

Type the legal description and address below.

All of the West Half (W1/2) of Section 16, Township 6 South, Range 71 West of the Sixth Principal Meridian, Jefferson County, Colorado.

SAVE AND EXCEPT, that portion thereof lying northerly of the south right of way line of Shadow Mountain Drive, as described in that document recorded in the records of the Jefferson County Clerk and Recorder at Reception No. F0829056 and that Parcel of Land described and depicted as Parcel 1 of the Plat of Exemption Sec. 16, T6S, R71W, 99015231EXP1 as recorded in the records of said Clerk and Recorder at Reception No. F1152563.

Said Parcel being subject to any existing easements and/or rights of way of whatsoever nature.

This description was prepared on the 9th day of July, 2024, by Patrick M. Steenburg, Colorado Professional Land Surveyor 38004 from provided exhibits, without benefit of land survey or title research.

Section 16 Township 6 S. Range 71 W.

Calculated Acreage 235 Acres Approximately Checked by: Becky Daleske

Address Assigned (or verified) (Vacant Land) Shadow Mountain Drive

COMMUNITY MEETING SUMMARY

COMMUNITY MEETING SUMMARY

Case Number

22-117793 CMT

Meeting Date

7/27/2022

Approx. # of Citizens

332

Signed in

Meeting Location

Virtual CMT - Zoom

Subject Property

61-163-0-001

Property Owner

CO State Land Trust

Applicant/Representative

Phil Bouchard/ Jason Evan

Summary of the Applicant's Presentation

Powerpoint slides of concept overview, project scope, sample trail network, sustainability options and Frequently Asked Questions

Information Presented/Format of the Meeting

Zoom - Panelist presentation and Q&A

Overall Impression/Tone of Meeting

Main Points/Issues Raised by Citizens/Applicant's Response

CPW be notified? Yes.

Will there be a Federal Nexus? Not anticipated unless US Army of Engineers involved

Smoking? No smoking allowed on-site.

Trespassing and access? Staff patrols, no access proposed to the north

Seasonality and operations? Park operations will not operate in times of snow (Fall/Winter/Spring

Illumination? Park will not be lit in evenings; no night riding proposed.

Sound? Remaining trees screen much of the sound. Quietest lift proposed

Will there be retail on the property? No alcohol sales or restaurant - excluded from proposal

What happens if the business fails and backs out after development? CO Land Board requires mitigation of development if occurs.

Water? Planning the same demand as two single family dwellings.

How would you handle hikers who wander in to the bike park? Signs, bike patrol all day every day. Trails won't stretch to property boundaries.

Compatibility? Applicant sees the proposal as less intense than if it were developed under A-2 as housing or otherwise.

COMMUNITY MEETING SUMMARY

Case Number

20-129278 CMT

Meeting Date

1/5/2021

Approx. # of Citizens

300+

Signed in

Meeting Location

Virtual CMT - Zoom

Subject Property

20950 S. Buffalo Creek Road

Property Owner

State of Colorado

Applicant/Representative

Jason Evans & PhilBouchard

Summary of the Applicant's Presentation

To discuss a Location & Extent or Rezoning for a lift-assisted bike park.

Information Presented/Format of the Meeting

Webinar Format: Intro, Overview, About, Community Benefits, State/County Feedback, Site Plan, Timeline, Q&A

Overall Impression/Tone of Meeting

Mixed. Many very opposed. Some very supportive. Chat function is very difficult to gauge volume of support or opposition

Main Points/Issues Raised by Citizens/Applicant's Response

Traffic and roadway safety - Concerns over Shadow Mountain Rd. Many claims of unsafe roadway conditions. Looking to the County and traffic study to see what mitigation will be required.

Wildlife - Elk migration and concerns of wildlife disruption. Applicants discuss 483 acre parcel will be able to mitigate these concerns.

Parking - Volume of visitors will be limited by trail lifts. Residents voiced some concern of commercial use in residential areas.

Fire - Concerns of wildfire. Applicant discussed State requirement of wildfire mitigation plan 200+ acres.

Water - Not discussed in detail or length.

Emergency Access/Evacuation - concerns that Mountain Biking is excessively dangerous. Studies discussed about injury compared to skiing injury are less, but more than zero.

Alcohol - concerns of overconsumption and driving

Compatibility of commercial use and residential area

REFERRAL COMMENTS

Dylan Monke

From: Kurz - CDPHE, David <david.kurz@state.co.us>
Sent: Thursday, May 30, 2024 3:38 PM
To: Dylan Monke
Cc: Mitch Brown; Emily Wong - CDPHE
Subject: --{EXTERNAL}-- Re: FW: 23-102980 RZ: Shadow Mountain Bike Park

This Message Is From an External Sender

This message came from outside your organization.

Report Suspicious

Dylan,

Regarding the Shadow Mountain Bike Park, second referral documents, the general comments from the CDPHE local referral response are still appropriate. We also have some comments worth noting regarding the wastewater treatment design and reviews. A number of the descriptions could indicate a possible misunderstanding of later needs for the wastewater treatment system.

As the wastewater treatment system is now projected to have a capacity of greater than 2,000 gpd, the treatment system will meet the definition of a domestic wastewater treatment works under the Colorado Water Quality Control Act.

Section 3.3 of the Stantec Engineering Report, revised April 2024 (filename SMBP - OWTS - Second Referral Response.PDF), notes in part:

Design and construction of the OWTS will be in accordance with Jefferson County OWTS requirements including site application and design approval (\$25-8-702, C.R.S.) and the discharge permit requirements in the Water Quality Control Act (\$25-8-501, et seq. C.R.S.). (emphasis added)

To clarify, the site location application and design review requirements of §25-8-702 C.R.S. are state requirements elaborated in Regulation 22 Site Location and Design Regulations for Domestic Wastewater Treatment Works, 5 CCR 1002-22. This is likely known by the applicant since the "site application and design" phrase is included, but it is worth noting to avoid misunderstanding. Although the county may have some permitting requirements, the review of the site location application and design for the domestic wastewater treatment works will be conducted at the state level.

Similarly, section 4.4 of the Stantec report notes in part:

Wastewater Discharge will be permitted through Jefferson County and the associated OWTS design and construction process. And the State Discharge Permit process. (emphasis added)

As noted above, the design review of a domestic wastewater treatment works will be conducted at the state level.

Sections 3.9 and 5.3 of the Stantec report indicate the wastewater treatment system is expected to consist of a septic tank and leach field with the anticipated cost of \$18,500 (section 5.5). Please note that the domestic wastewater treatment works must meet effluent limits in the subsequent state issued discharge permit. Advanced treatment beyond a septic tank and leach field is likely to be needed to meet expected effluent limits in a state discharge permit. In addition, there are fees

associated with the state review process for the site location application and design. Cost estimates may not be critical at this point in time, but worth noting for clarity.

Hope this is helpful. Please let me know if you need additional information or have any questions.
Thanks, David

David Kurz, P.E.
Lead Wastewater Engineer
Engineering Section



P 303.692.3552 | F 303.758.1398
4300 Cherry Creek Drive South, Denver, CO 80246
david.kurz@state.co.us | <https://cdphe.colorado.gov/water-quality> [cdphe.colorado.gov]

24-hr Environmental Release/Incident Report Line: 1.877.518.5608

On Tue, May 21, 2024 at 2:08 PM Dylan Monke <dmonke@co.jefferson.co.us> wrote:

Hello,

I was referred to you by our Public Health Department.

Could you please take a gander at the attached and let me know if your agency has any comments?

Thanks,

Dylan Monke

Jefferson County Planning and Zoning

Permitting Supervisor

303-271-8718

dmonke@jeffco.us | planning.jeffco.us

Help us shape the future of Jefferson County by visiting the Together Jeffco website!

Click the image below to visit our website: <https://togetherjeffco.com>



We encourage scheduling an appointment to see staff during our office hours Monday - Thursday. Please schedule [appointments](#) and submit [applications](#) online. Go to planning.jeffco.us for more information.

From: Dylan Monke
Sent: Monday, May 20, 2024 8:57 AM
To: cdphe_localreferral@state.co.us
Subject: 23-102980 RZ: Shadow Mountain Bike Park
Importance: High

Hello,

We're in the referral process for a Special Use to allow a lift-assisted Bike Park in the Conifer Area. The proposed uses will service more than 2,000 persons and while I believe it will require a Public Water System, I'm unaware of more comprehensive comments from your agency.

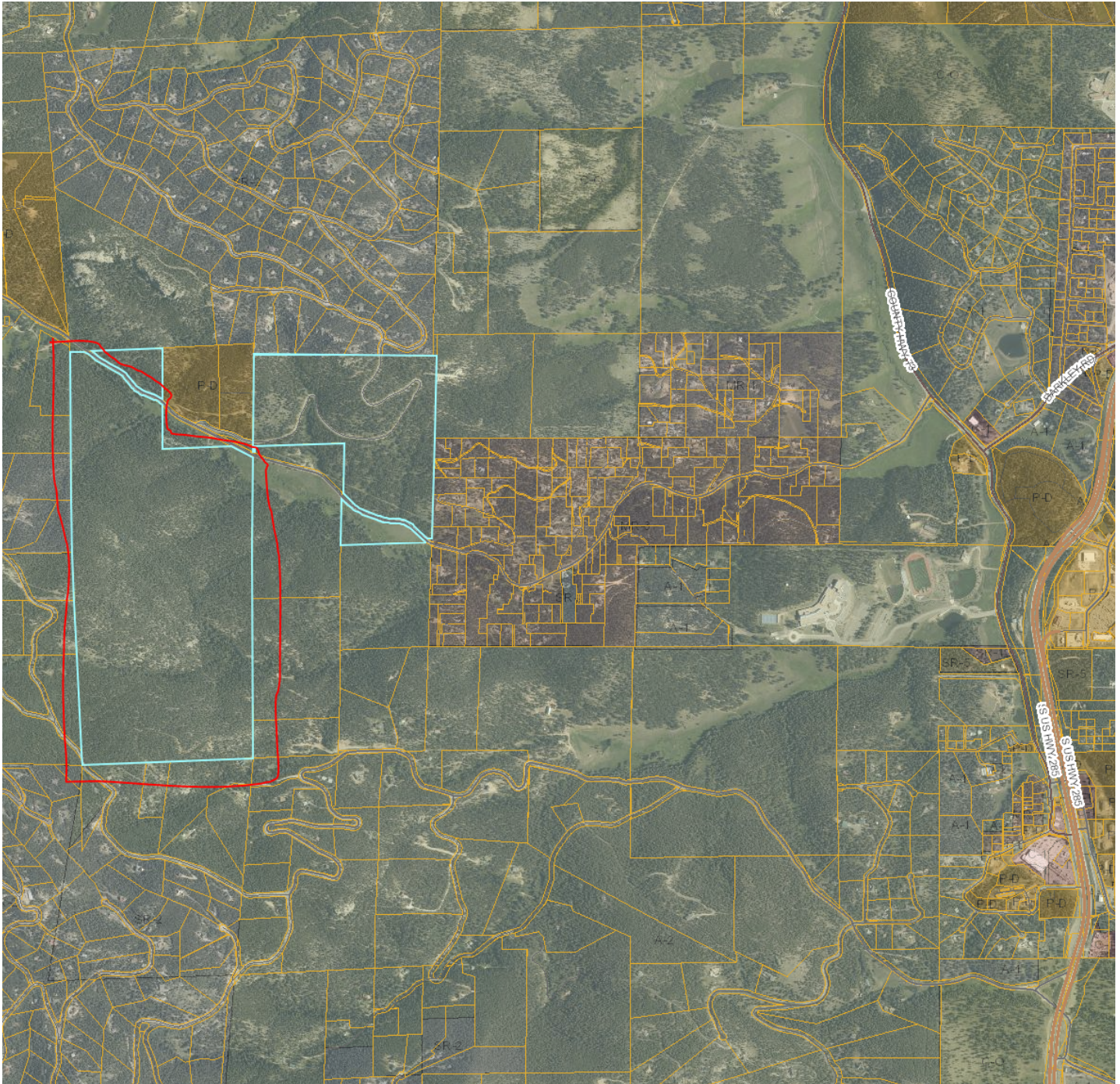

Parcel shown above

Could you please provide comments on the attached at your earliest convenience?

Thanks,

J E F F E R S O N



COUNTY COLORADO

Boards and Commissions

Historical Commission

Memorandum

May 28, 2024

Rezoning Shadow Mountain Bike Park (Case #23-102980 RZ) Third Referral

Project:

FSBR, LLC is applying to develop a portion of the property (235 ac of 306 ac) as a bike park - a "Class III commercial recreation facility" - which is a Special Use in the Agricultural zone district. The Property is zoned Agricultural Two ("A2"), currently undeveloped, and occasionally used for agricultural and grazing purposes. The project is located within the State Land Board's (SLB) Shadow Mountain parcel. The Property will remain under the ownership of the Colorado SLB. The Colorado SLB and the applicant will agree on a permit to enable operations.

The applicant included the following project information: "The project will maintain much of the natural landscape. The low-impact concept will open more than 300 acres of forest to the public and deliver wide-ranging benefits to the community. The proposal will also protect the property from more disruptive forms of development that conform to its current zoning. The project has been designed to respect the natural character of Shadow Mountain to the maximum extent possible by concentrating infrastructure development to the base area and the lift corridor. Additionally, a low-impact trail system will be dispersed throughout the property in a manner which will be shielded from Shadow Mountain Drive. Infrastructure includes a lift, single-access driveway, parking lot, an access road from main base to top terminal area, a day lodge, maintenance building, utilities, water storage tank, on-site wastewater management, buried power and powerline spur to top."

The applicant conducted a cultural and historical file search through the Colorado Office of Archaeology and Historic Preservation. The search identified 0 sites and 0 surveys within the project area. The applicant also consulted with the Conifer Historical Society via email on October 10, 2023 and followed up again on October 11 and November 19 to gather more information. The Conifer Historical Society to this date has not provided the applicant with specific information on the parcel, and in this correspondence referenced History Colorado as a resource. This information will be used to assess the resources near and in the project area and for formulating recommendations on the third referral.

Resources near the Project Area:

There are no recorded cultural resource surveys and sites in Section 16, T6S, R71W. Within a mile of Section 16, there is a prehistoric camp, a prehistoric lithic scatter, a stone circle, 3 historic trash scatters, 14 isolated historic features and finds, a historic homestead, and Staunton Ranch.

The Conifer Historical Society provided a document titled "Shadow Mountain History" that describes the history in the Conifer area and the project area beginning in 1873. "Shadow Mountain was the location of

the first homesteads granted in the Conifer area 150 years ago, and is considered to be its oldest neighborhood.”

“Homesteaders on Shadow Mountain engaged in agriculture, logging, and haying. There was work available at the Junction Hotel and Ranch. Many of the owners and their family members worked as hoteliers, storekeepers, or Postmaster. Small one-room schoolhouses, including the Junction School and the Hutchinson School, were built nearby. In 1894, the post office name was changed to Conifer. By the turn of the century, the Bradford Ranch in Conifer was well known as a community hub.”

“William Orr and his family were the last people to homestead on Shadow Mountain; their patent was proved in 1923. They mistakenly built their home in Section 16 instead of Section 9, land belonging to the State of Colorado. When Colorado became a state in 1876, the Enabling Act gave all federal public land in Sections 16 & 36 of every township to the state to benefit public schools. The Colorado State Land Trust was established to fulfill this mission. The Orr land became embroiled in litigation and was not settled for many years. Today, the land of Section 16 remains relatively untouched, one of the most pristine areas of wilderness in the area.”

“There have been significant archeological findings within a mile of the Section 16 parcel, establishing that Conifer has a long history predating modern settlement.”

The Conifer Historical Society requested that a cultural resource survey be completed in the project area, “which will provide tangible and lasting evidence of those who came before us, helping to identify, designate and protect the cultural resources of their community.”

Resources in the Project Area:

The cultural and historical file search through the Colorado Office of Archaeology and Historic Preservation identified 0 sites and 0 surveys within the project area.

Project Determination of Effect: No determination of effect is provided, since there are no known cultural resources recorded in the project area.

Mitigation Measures: No mitigation requirements are identified, since there are no known cultural resources recorded in the project area.

Other Information

The Jefferson County Historical Commission (JCHC) and the applicant met on March 13, 2024 to discuss the recommendations from the second referral dated January 22, 2024. The applicant formally replied on April 12, 2024 as part of the third referral. Below are the replies to JCHC recommendations:

Recommendation 1. A Historical, Archaeological and Paleontological Report/(Plan) shall be prepared in accordance with Land Development Regulation, Section 31 and shall address the alternatives for protection of any historical, archaeological and/or paleontological sites. Once the Historical, Archaeological and Paleontological Plan is completed and approved, if historical, archaeological and paleontological resources are present or discovered during site preparation, the applicant shall notify the Jefferson County Planning and Zoning Division to determine the disposition and necessary protection, excavation, or recovery of the resource(s).

Recommendation 3. Although the applicant is not required to conduct an on-the-ground survey, JCHC believes it is the most reliable approach for identifying cultural resources and reducing potential impacts to them during planning and not during development, which can result in project delays and unnecessary damage to cultural resources.

The applicant committed to an on-the-ground survey in certain parts of the project area and suggested delaying the preparation of an Historical, Archaeological, and Paleontological Report/Plan until the design/development phase, since a report would be prepared to describe the project area and survey results at that point. JCHC was willing to consider these next steps and accept a response letter instead of a Report/Plan for the third referral.

The applicant committed to the following:

- We will prepare a Historical, Archaeological, and Paleontological Report/Plan in accordance with Land Development Regulation, Section 31. The information required according to LDR Section 31 will be included in the report that follows cultural surveys as required per Section 106 compliance.
- We are committed to conducting cultural surveys in areas with higher levels of ground disturbance, which includes: the driveway, parking lot/base area, and area around the top of the chairlift.
- We would like to invite a member of JCHC to assist in the flagging of trail alignments during the design and development phase to determine the presence (or likelihood therein) of cultural resources, if necessary.
- If historical, archaeological and paleontological resources are discovered during site preparation or construction, all construction in the immediate vicinity shall cease and the applicant shall notify the Jefferson County Planning and Zoning Division and the proper authorities to determine the disposition and necessary protection, excavation, or recovery of the resource(s).

Recommendation 2. The mountain and historic landscape are basically intact throughout the project area. JCHC will work with the applicant to consider this landscape during project design and developing mitigation measures.

The applicant did not respond to this recommendation.

Kris Laubis, Shadow Mountain resident (Email, 4/23/2024)

“The developers of the Shadow Mountain Bike Park recently submitted their response to Jeffco P&Z. I have read their response to the recommendations that JCHC made and I am perplexed. There was mention in the 3/4/24 minutes that the developers were seeking a meeting. However, the 4/1/24 minutes of JCHC have not yet been posted on the website.

Did the commission in fact meet with the developers? Is the attached report that they submitted to P&Z accurate?

This paragraph was particularly troubling:

In response to these recommendations, we scheduled a meeting with the JCHC to better understand their expectations and establish next steps. In the meeting, we discussed our commitment to an on-the-ground survey in certain parts of the project area and suggested delaying the preparation of an Historical, Archaeological, and Paleontological Report/Plan until the design/development phase, since a report would be prepared to describe the project area and survey results at that point anyway. In the meeting, JCHC was willing to consider these next steps and accept a response letter (this letter) instead of a Report/Plan in this referral.

I understand that JCHC's hands are tied because they are not an CLG and the most they can do is “recommend”. However, it sounds like the developers persuaded JCHC to “kick the can down the road” until **after** the development is approved by the JCBC. Shouldn't the JCBC have the benefit of knowing this information before they make their decision? At what point in development phase would this survey take place? The toothpaste can't be put back in the tube. Once this commercial project commences, irreparable damage could be done to the potential indigenous finds, landscape, wildlife habitat, traffic, etc. Who will be monitoring the developers as they conduct this survey? If you were the developer and

you discovered an artifact or arrowhead with millions of dollars at stake, would that discovery end up in your pocket or be made known to the JCHC? Why are they only committing to a survey in certain parts of the proposed development?

As a 40+ year resident of Conifer, past board member of CHSM, and 30-year resident on Shadow Mountain I am deeply saddened that more can't be done to preserve and protect our unique, rural mountain heritage. It makes no sense to plop a commercial development in the center of a residential area, adjacent to a conservation easement.

JCHC public meeting (5-6-24)

Concerned residents from Shadow Mountain attended the public meeting to further express their concerns and strongly expressed the need to conduct the cultural resource survey before a decision is reached on the rezoning application.

Jefferson County Historical Commission Conclusion and Recommendation:

JCHC appreciates the applicant's willingness and commitment to conduct a cultural resource survey as part of the Historical, Archaeological, and Paleontological Report/Plan. This documentation can be submitted as part of the land development application. JCHC is open to receiving this information as early as possible for review. JCHC has the following recommendations:

Recommendation 1. Cultural resource professionals permitted by the Colorado Office of Archaeology and Historic Preservation, as per CRS 24-80-401 to 410 and approved by the State Land Board will conduct the cultural resource survey and provide recommendations on the eligibility of and effects to identified cultural resources. The cultural resource professionals will also be directly involved with identifying mitigation measures and treating any discoveries.

Recommendation 2. The cultural resource survey will include areas that are earth-disturbing and can damage cultural resources directly and indirectly, including the 16 miles of trails planned for the development.

Recommendation 3. The historic mountain landscape is basically intact throughout the project area. The mountain landscape and rural setting need to be considered during project design and developing mitigation measures. The proposal should choose building materials and design the site to consider and complement the surrounding environment, landscape, and mountain view. This approach will preserve the historical integrity and natural beauty of the rural mountain landscape, ensuring it remains a valuable heritage asset for future generations.

Tugce Ucar Maurer
Planner II, Long Range Planning
Jefferson County Planning and Zoning

May 28, 2024

Dear Tugce,

The Historical Preservation and Landmarks Committee of the Jefferson County Historical Commission (JCHC) has reviewed *Rezoning Shadow Mountain Bike Park (Case #23-102980 RZ) Third Referral*. The attached memo contains more details about the review. JCHC has the following recommendations:

Recommendation 1. Cultural resource professionals permitted by the Colorado Office of Archaeology and Historic Preservation, as per CRS 24-80-401 to 410 and approved by the State Land Board will conduct the cultural resource survey and provide recommendations on the eligibility of and effects to identified cultural resources. The cultural resource professionals will also be directly involved with identifying mitigation measures and treating any discoveries.

Recommendation 2. The cultural resource survey will include areas that are earth-disturbing and can damage cultural resources directly and indirectly, including the 16 miles of trails planned for the development.

Recommendation 3. The historic mountain landscape is basically intact throughout the project area. The mountain landscape and rural setting need to be considered during project design and developing mitigation measures. The proposal should choose building materials and design the site to consider and complement the surrounding environment, landscape, and mountain view. This approach will preserve the historical integrity and natural beauty of the rural mountain landscape, ensuring it remains a valuable heritage asset for future generations.

Please forward our review and recommendations to the case manager.

Sincerely Yours,

//s// Dan Haas, Richard Scudder

Co-Chairs, Historical Preservation and Landmarks Committee
Jefferson County Historical Commission

Attachment: JCHC Memo

MEMO

TO: Dylan Monke
 Jefferson County Planning and Zoning Division

FROM: Tracy Volkman
 Jefferson County Environmental Health Services Division

DATE: May 22, 2024

SUBJECT: Case #23-102980 RZ
 Shadow Mountain Bike Park
 Philip Bouchard
 61-163-00-001

PROPOSAL SUMMARY

Special Use Application for Development of a day-use lift-served bike park as a Class III Commercial Recreation Facility for 1200 guests per day at maximum occupancy.

COMMENTS

Jefferson County Public Health (JCPH) provided comments regarding this proposal on November 18, 2020, June 1, 2022, March 22, 2023, and on January 8, 2024. We reviewed the proposed documents submitted by the applicant for the third referral for the rezoning/special use process and have the following updated comments:

The applicant must submit the following documents or take the following actions prior to a ruling on the proposed rezoning/special use of this property. NOTE: Items marked with a “✓” indicate that the document has been submitted or action has been taken. **Please read the entire document for requirements and information. Please note additional documentation may be required. Failure to provide the required documentation may delay the planning process.**

REZONING REQUIREMENTS (Well and OWTS requirements)

✓	Date Reviewed	Required Documentation/Actions	Refer to Sections
		Obtain written documentation that this site can support a conforming state permitted onsite wastewater treatment system (OWTS) from the Colorado Department of Public Health and Environment (CDPHE), Water Quality Division. The applicant must obtain Site Approval at the time of site development from the CDPHE for the onsite wastewater treatment system(s) as the design flow of the OWTS exceeds 2000 gallons per day.	Wastewater

✓	Date Reviewed	Required Documentation/Actions	Refer to Sections
	At the time of site development, including the development of bike trails only for systems less than 2000 gpd.	Obtain valid OWTS permits from JCPH for any OWTS, including closed vault systems, that have a design capacity of less than 2000 gallons per day at the time the site is developed, including the development of bike trails only at the time the site is developed.	Wastewater
✓	03/21/2023	Submit a notarized Environmental Questionnaire and Disclosure Statement in accordance with the Jefferson County Zoning Resolution and Land Development Regulation (LDR) Section 30.	Environmental Site Assessment

WATER (LDR 21)

The Jefferson County Zoning Resolution (Section 9 C.21) and the Land Development Regulation (LDR) Section 21.B.2.a (1) requires proof of legal water, such documentation may include, but is not limited to, a copy of the well permit or water court decree. The Colorado Division of Water Resources (CDWR) is the governing authority for wells. As such, the applicant should contact the CDWR at 303.866.3581 who will determine if the applicant has a legal right to the water supply.

Please note that the well(s) will serve as a drinking water supply that serves a population of at least 25 people per day for at least 60 days per year and is not a non-transient, non-community water system or a community water system. As such, the water supply would meet the definition of a transient, non-community water system as defined in the Colorado Primary Drinking Water Regulations. **The applicant must contact the Water Quality Control Division, Colorado Department of Public Health and Environment (CDPHE) at 303.692.3500 for a PWSID number and or permit as required as this well water supply will be regulated by the CDPHE, Water Quality Control Division.**

JCPH advises all parties to note that the long-term dependability of any water supply in Colorado, be it surface water, ground water, or a combination of surface water and ground water, cannot be guaranteed. All ground water and surface water supplies are subject to fluctuations in precipitation. During periods of drought, it will be necessary to carefully manage all uses of water so that the basic water supply needs for human health can be met.

WASTEWATER (LDR 22)

Sanitation

This facility will require either a State or JCPH permitted onsite wastewater treatment system(s) (OWTS), which includes closed vault systems, for sanitation services.

Onsite Wastewater Report (Form 6001)

The applicant re-submitted a complete Onsite Wastewater Report (Form 6001) in accordance with LDR Section 22.B.2. (a) revised in April 2024 prepared by Stantec Consulting Services. The Shadow Mountain Bike Park (SMBP) Engineering Study Project No. 181711248 estimated the

total daily wastewater flow to be 4,320 gallons per day. This study did not include the proposed food service facility in the day lodge from the previous submittal.

4.2 Population and Employment

The applicant estimates that there will be up to 30 onsite employees in a given day. The maximum day guest population is estimated to be 1200.

4.3 Wastewater Demand

Wastewater is estimated to be 80% of water demand. The Shadow Mountain Bike Park wastewater treatment requirements is estimated to be 4320 gpd (5400 x 0.8). An OWTS constructed per Jefferson County requirements will be constructed to treat the wastewater prior to discharge through an anticipated leach field.

The submitted Shadow Mountain Bike Park Official Development Plan indicates that there will be up to a maximum of 1,200 guests per day and 30 onsite employees. Using Appendix A, Estimated Daily Wastewater Flow, of the current Jefferson County Onsite Wastewater Regulations and the amended number of guests from 300 to 1,200 per day, we estimate that approximately 6,450 gallons of wastewater will be generated per day by guests and at a minimum of 450 gallons per day (gpd) for employees. See following table:

Jefferson County Public Health Estimated Daily Wastewater Flow Per Day (Using Appendix A - Onsite Wastewater Treatment)

Use	# of persons per day	Gallons per person per Day (gpd) per JCPH OWTS Regulations	Total Gallons of Wastewater Per Day
Employees	30	15	450
Guests	1200	5	6000
Total			6450

State Permitted OWTS

Any OWTS that exceeds the average daily flow of 2,000 gallons per day or more per property must comply with the Colorado Water Control Act, Article 8, Title 25 of the Colorado Revised Statutes, and Regulations adopted by the Colorado Water Quality Control Commission. Site Approval from the CDPHE is required prior to the approval of this proposed development. JCPH will provide review and comment to the CDPHE on the site application as requested. The applicant must contact the CDPHE, Water Quality Division at 303.692.3500 for this permit and we request that the applicant obtain written documentation from CDPHE that the property can support a State permitted, conforming OWTS. It is JCPH's understanding that if a day lodge, maintenance building with restroom,

and or a restroom building, a Site Development Plan (SDP) will be required by Jefferson County Planning and Zoning. At that time, prior to supporting an SDP, the applicant must obtain Site Approval from the CDPHE for the OWTS.

JCPH (County) Permitted OWTS

If the applicant intends to build this project using a phased approach, for example, building bike trails and no day lodge, maintenance buildings, etc., the OWTS, including closed vaults, may not exceed the 2,000 gallons per day and then would require a JCPH (County) issued OWTS permit. The OWTS will require a totalizing flow meter and monthly flows will be required to be submitted monthly to JCPH for review. If the gallons per day exceed the OWTS design, the owner of the property will be required to install a conforming OWTS that complies with local and state regulations and policies.

Prior to installing, altering, upgrading, remediating, or repairing an OWTS the applicant must receive a valid permit from JCPH. The applicant must submit an OWTS application, associated documents, and applicable fees to this Department for an approved permit to install the OWTS. Contact Mitchell Brown at 303.271.5767 or mlbrown@jeffco.us for more information on this process.

The owner may be subject to penalties per 25-10-113, C.R.S. if this property is found to be operating an unpermitted OWTS.

Jefferson County Onsite Wastewater Regulations, Section 6 Enforcement:

6.1 Penalties Per §25-10-113, C.R.S.

- A. Any person who commits any of the following acts or violates any of the provisions of this section commits a Class 1 petty offense as defined in §18-1.3-503, C.R.S.:
1. Constructs, alters, installs, or permits the use of any OWTS without first having applied for and received a permit as provided for in §25-10-106, C.R.S.;

Sanitation for Food Service

Depending on the type of food service provided in the guest day lodge, the discharge to the OWTS may be required to be calculated into the total gallons of wastewater generated per day. This must be provided to the CDPHE, Water Quality Division as part of the Site Application or for a JCPH permitted system.

ENVIRONMENTAL ASSESSMENT (LDR 30)

JCPH has reviewed the Environmental Questionnaire and Disclosure Statement. The applicant checked "No" on all categories of environmental concern on the cover sheet. From this information, it does not appear that any recognized environmental conditions exist which would negatively impact the property.

REGULATED FACILITIES

The applicant indicated in March 2023 that food and beverages would be provided from Food Trucks at this site for retail food service for guests. The submitted Shadow Mountain Bike Park (SMBP) Official Development Plan states that food and beverage vendors will be an Accessory Use.

If a proposed retail food service establishment is proposed, **which includes “grab and go” food service** in the day lodge, it will be subject to a plan review, yearly licensing and routine inspections by this Department. Please email health_eh_rf_plan_review@jeffco.us for specific requirements. "Retail food establishment" means a retail operation that stores, prepares, or packages food for human consumption or serves or otherwise provides food for human consumption to consumers directly or indirectly through a delivery service, whether such food is consumed on or off the premises or whether there is a charge for such food Colorado Revised Statutes 25-4-1602(14).

The SMBP Sensory Impact Assessment – Noise report states that the food service will be provided from Food Trucks at the bike park. Each Food Truck must have a valid Colorado Retail Food Establishment License for Mobile Units. Licenses issued by the City and County of Denver are not valid outside of Denver. If the Food Truck holds only a Denver County retail food service license, contact publichealthtemporaryfoodservice@jeffco.us for more information on licensing requirements to operate in Jefferson County.

MAINTENANCE FACILITIES

Above ground storage fuel tanks with total tank capacity of 660 to 40,000 gallons are regulated by the Colorado Department of Labor and Employment, Division of Oil and Public Safety. They may also be regulated by the local fire department. Above ground storage tanks should also have secondary containment systems to prevent leakage of fuel or chemicals onto the ground. If underground piping for fuel is associated with the above ground storage tank, this may also be regulated by CDLE. Contact the CDLE, Division of Oil and Public Safety at 303.318.8500 and the jurisdictional fire department for registration, permitting, inspection and monitoring requirements.

Hazardous materials (oil, maintenance equipment fluids, etc.) or industrial waste that is generated from this operation cannot be disposed of into the onsite wastewater treatment system(s). Onsite disposal is prohibited. Any waste of this type must be recycled or disposed of at the proper waste disposal site, in accordance with local, state, and federal regulations.

Any waste materials generated from repair operations must be properly contained and stored on the site prior to transporting to an approved recycling or disposal facility. On-site disposal of any such materials is prohibited. Sufficient control measures to prevent any spillage from impacting the area should be in place.

AIR

Land development projects that are greater or equal to 25 contiguous acres and/or 6 months in duration typically require the submission of an Air Pollutant Emission Notice (APEN) and may require an air permit. Furthermore, Regulation No. 1 of the Colorado Air Quality Control Commission requires the developer to follow a Fugitive Dust Control Plan to mitigate dust problems during demolition, land clearing and construction activities. This department will investigate any reports of fugitive dust emissions from the project site. If confirmed, a notice of violation will be issued with appropriate enforcement action taken by the State.

NOISE

Since this facility is essentially surrounded by residential properties, noise levels emitted from this property are more stringent and must comply with the Colorado Revised Statutes (Sections 25-12-101 through 108) which stipulates that the maximum residential noise levels must comply with the following 25 feet from the property line:

- 55dB(A) between 7:00 a.m. and 7:00 p.m.
- 50dB(A) at all other times.

The SMBP Sensory Impact Assessment – Noise dated March 21, 2023, prepared by Stantec Consulting Services, Project Number: 195602713 concluded the following:

The results of the noise modelling for operational noise predict that noise levels at the nearby sensitive noise receivers will comply with the Jefferson County requirements.

Additionally, construction noise impacts from equipment predicted to be required for the construction of the Shadow Mountain Bike Park are expected to be below the applicable construction noise limits.

This assessment was completed using the preliminary site layout and equipment locations provided by the SE group. Locations of equipment and equipment selection may change and additional construction equipment, not considered in this assessment, such as impact pile drivers may be required during construction. Stantec recommends that this study be updated when final design is completed to evaluate compliance with applicable noise criteria and validate the assumptions made for this assessment.

Colorado Revised Statute 25-12-103 classifies noise that exceeds the maximum permissible noise level as a public nuisance, which is a civil matter between the property owner and the complainant. Please note: JCPH and the Colorado Department of Public Health and Environment do not enforce noise complaint nuisances.

NOTE: These case comments are based solely upon the submitted application package. They are intended to make the applicant aware of regulatory requirements. Failure by Jefferson County Public Health to note any specific item does not relieve the applicant from conforming to all County regulations. Jefferson County Public Health reserves the right to modify these comments, request additional documentation, and or add appropriate additional comments.



Planning & Property Department
809 Quail Street, Building 4
Lakewood, Colorado 80215
(303) 982-2584

May 17, 2024

Dylan Monke, Permitting Supervisor
Jefferson County Planning and Zoning Department
100 Jefferson County Pkwy, Ste. 3550
Golden, Colorado 80419

RE: 23-102980RZ Shadow Mountain Bike Park

Dear Dylan,

Thank you for information regarding the referenced case currently under review. Jeffco Public Schools sees no direct impact on its facilities from this case.

Should you need additional information, please contact me.

Sincerely,

Jeffco Public Schools

Chad Bridges
Planner, Facilities Planning & Property

R:\FAC\CMFPD\GIS\Subdivisions\2024 Referrals\Jefferson
County\ShadowMountainBikePark\20240517_ShadowMountainBikePark.docx

PLANNING ENGINEERING MEMORANDUM

TO: Dylan Monke, Case Manager
FROM: Nathan Seymour, Planning Engineering
DATE: May 30, 2024

RE: 23-102980RZ; Special Use Application for Shadow Mountain Bike Park at 61-163-00-001 adjacent to Shadow Mountain Drive, Conifer CO 80433

SPECIAL USE COMMENTS

1. Transportation: No additional comments.
2. Phase I Drainage Report and Plan: No additional comments.

OTHER CONSIDERATIONS

1. Site Development Plan: The applicant needs to be aware that prior to the issuance of a building permit, a Site Development Plan Approval is required; please see the Zoning Resolution, Section 9 for more details on the requirements for the Site Development Plan.
2. Floodplain Development Permit: A Jefferson County Flood-prone area is located on the northern portion of the property along North Turkey Creek. Construction, including grading and/or access in this area will require a Floodplain Development Permit through Jefferson County Planning & Zoning. This should be submitted at the same time as the Site Development Plan.

CONCLUSION

These comments are based on the requirements of the Jefferson County Land Development Regulation (LDR), the Jefferson County Zoning Resolution (ZR), the Jefferson County Storm Drainage Design and Technical Criteria (SDD&TC) and the Jefferson County Transportation Design & Construction Manual (TD&CM). The comments are intended to make the applicant aware of regulatory requirements. Failure by Jefferson County Planning and Zoning to note any specific item does not relieve the applicant from conforming to all County regulations. Jefferson County Planning and Zoning reserves the right to modify these comments, request additional documentation, and or add appropriate additional comments.

If there are any questions, please contact Nathan Seymour at 303-271-8751.

NRS
Attachment/Enclosure
c: File

Memorandum

To: Dylan Monke
Planner

From: Patrick O'Connell
Engineering Geologist

Date: May 28, 2024

Re: Shadow Mountain Bike Park, Case No. 23-102980RZ

I have reviewed the submitted documents for the subject project. I have the following comments:

1. The site is not within a zoned or unzoned geologic hazard area and reports are not required with the rezoning process.
2. The property is located within the Mountain Ground Water Overlay District. Based the uses (bike park, lodge, maintenance building) on 306 acres, it appears the water requirement will not exceed the 0.28 acre feet per acre per year threshold as described in Section 21 of the LDR. If the water requirement exceeds 0.28 acre feet per acre per year, an Aquifer Test in accordance with Section 21 of the LDR is required with the rezoning application. If the water requirement exceeds 0.10 acre feet per acre per year, an Aquifer Test in accordance with Section 21 of the LDR is required with the SDP application. The estimated water requirement is 0.04 acre feet per acre per year.
3. The applicant has submitted a plan (April 17, 2024) that describes the process to obtain legal rights to the water supply and the number of guests has been updated (1200 max). Adequate legal water rights will be required with the SDP process.
4. The Water Availability Analysis (WAA) has been revised based on water demand requirements provided by the applicant and County staff. The use is unique and a bike park is not listed in multiple references, therefore, County staff utilized 4 gallons per day (gpd) per guest (1200 guests based on revised ODP). The value utilized in Stantec's October 23, 2023 Engineering Study was 4 gpd, however, no source data was provided. I discussed this with the applicant's representative. Based on the values and ODP, the estimated total annual withdrawal is ~4.72 af and a consumptive use of ~0.8 af.
5. Grading within the Jefferson County Floodplain Overlay District (flood prone area) will require a separate Floodplain Development Permit.



March 20, 2023

Dylan Monke
Jefferson County Planning and Zoning
Transmission via email: dmonke@co.jefferson.co.us

Re: Shadow Mountain Bike Park Rezoning
Case Number 23-102980 RZ
Pt. W½ Sec. 16, T6S, R71W, 6th P.M.
Water Division 1, Water Districts 9 & 80

Dear Mr. Monke:

We have reviewed the above referenced application for Rezoning/Special Use for a chairlift-accessed mountain bike park. The submitted material does not qualify as a “subdivision” as defined in section 30-28-101(10)(a), C.R.S. Therefore, pursuant to the State Engineer’s March 4, 2005 and March 11, 2011 memorandums to county planning directors, this office will only perform a cursory review of the referral information and provide comments regarding the proposed water supply. The comments will not state an opinion on the adequacy of the water supply or the ability of the water supply plan to satisfy any County regulations or requirements, and cannot be used to guarantee the physical availability of water or the issuance of a well permit.

The applicant proposes to construct and operate a mountain bike park on a 235-acre portion of a 306-acre parcel owned by the Colorado State Land Board. The facility will have a chairlift to access approximately 16 miles of mountain biking trails for varying ability levels. A lodge and parking area for up to 300 vehicles will be located near the base of the chairlift. The lodge is anticipated to provide guest services including indoor seating, ticketing, restrooms, changing rooms, bike and equipment rentals, and a deck for outdoor guest space and seating. The lodge will not contain a kitchen space. Instead, the applicant plans to partner with local food truck vendors to meet food and beverage needs for guests. The property will also contain a maintenance building with an additional restroom and 20 employee parking spaces. The proposed source of water supply for the property is a well to be constructed onsite.

At full build-out, water requirements for the property are estimated to total 1.57 acre-feet per year based on an estimated water requirement of 4 gallons per guest per day and an average of 300 guests per day, and an estimated water requirement of 10 gallons per day per employee and an average of 20 employees per day, 365 days per year. To allow for variability in water use, including during potential special events, the applicant is proposing to use a water requirement of 2 acre-feet of water per year. The applicant does not anticipate needing this full amount of water during the first few years of construction and operation. Therefore, the applicant proposes to obtain a commercial exempt well permit for initial operation. This type of well permit would allow for the withdrawal of up to ⅓ acre-foot of water per year for use in drinking and sanitary facilities inside a commercial business. The well would be required to be equipped with a totalizing flow meter with



meter readings reported to this office on a monthly basis. A commercial exempt well may also be permitted for fire-fighting use, including to fill a storage tank for this purpose so long as the outlet to the storage tank is kept capped and locked and available only for use in fighting fires. The applicant has stated that they are aware that they would need to pursue obtaining a non-exempt commercial well permit as visitation grows, and a plan for augmentation. A non-exempt well permit would be required to withdraw more than 1/3 acre-foot of water per year, and could only be issued if the well were first included in a plan for augmentation decreed by the water court or a substitute water supply plan approved by the state engineer. The ability for the applicant to obtain well permit(s) and the allowed use(s) will be determined at the time permit application(s) are submitted to and reviewed by the State Engineer's Office.

A detention pond is proposed to be constructed in the southeast portion of the site to capture runoff from the lodge and parking area. Water from the detention pond will be discharged to North Turkey Creek. The applicant should be aware that, unless the structure can meet the requirements of a "storm water detention and infiltration facility" as defined in section 37-92-602(8), C.R.S., the structure may be subject to administration by this office. The applicant should review the Division of Water Resources' Administrative Statement Regarding the Management of Storm Water Detention Facilities and Post-Wildland Fire Facilities in Colorado, available at <https://dwr.colorado.gov/services/water-administration/rainwater-storm-water-graywater>, to ensure that the notification, construction and operation of the proposed structure meets statutory and administrative requirements. The applicant is encouraged to use the Colorado Stormwater Detention and Infiltration Facility Notification Portal, located at <https://maperture.digitaldataservices.com/gvh/?viewer=cswdif>, to meet the notification requirements.

The applicant may need to obtain a permit from the U.S. Army Corps of Engineers prior to the commencement of any construction or other activities that may temporarily disturb or permanently fill any wetlands on site.

Should you or the applicant have any questions, please contact me at 303-866-3581 ext. 8249 or sarah.brucker@state.co.us for assistance.

Sincerely,



Sarah Brucker, P.E.
Water Resources Engineer

Cc: Referral file no. 30302



ELK CREEK FIRE PROTECTION DISTRICT

11993 South Blackfoot Road P.O. Box 607 Conifer, CO 80433

January 16, 2024

Jefferson County Planning and Zoning
Attn: Dylan Monke
100 Jefferson County Parkway
Suite 3550
Golden, Colorado 80419-3550

RE: 23-102980-RZ – 2ND REFERRAL SHADOW MOUNTAIN BIKE PARK

Dylan Monke:

The Elk Creek Fire Protection District has reviewed the re-zoning submittal for the above-mentioned project. Below are my comments based on the information submitted:

- Fire apparatus access roads would be required in accordance with the International Fire Code, Section 503.
 - The culverted crossing needs to be designed and built to handle the weight of fire apparatus.
 - The parking lot and work road needs to be designed and built to handle fire and EMS apparatus.
- The day lodge, maintenance shop and any other future permanent buildings need to meet the minimum fire code requirements:
 - The proposed water supply meets the minimum requirements of the adopted Fire Code with amendments. Water supply may be increased based on the design of the building.
 - Fire hydrant, fire pump, and fire alarm comments from the first referral have been addressed in the December 8, 2023 First Referral Response – Summary of Referral Comments – SMBP.pdf.
- These comments are based on currently available information. If plans or conditions change in the future, there may be additional requirements. A more detailed plan review would be conducted as more details become available.

Please contact me if I can be of further assistance.

Sincerely,

Rachel Rush
Fire Marshal
Elk Creek Fire Protection District

Dylan Monke

From: Justin Gutierrez <JGutierrez@Summitutilitiesinc.com>
Sent: Wednesday, January 3, 2024 7:22 AM
To: Dylan Monke
Subject: --{EXTERNAL}-- RE: [EXTERNAL EMAIL] 23-102980RZ - ELECTRONIC REFERRAL - EXTERNAL - Rezoning

This Message Is From an External Sender

This message came from outside your organization.

Report Suspicious

Good morning Dylan,

The Shadow Mountain Bike Park, 80433 is located in Colorado Natural Gas service territory. There are gas lines and appurtenances in surrounding roadway R.O.W.s and service lines and meter sets to surrounding homes. However, Colorado Natural Gas does not have any assets in the property and has no objections to the Rezoning for Shadow Mountain Bike Park, 80433.

Please call 811 prior to digging!

Thanks,

Justin Gutierrez
Engineer
Summit Utilities, Inc.
jgutierrez@SummitUtilitiesInc.com
Office: (720) 981-2123 [x1187]

From: AUTOMAILER@JEFFCO.US <AUTOMAILER@JEFFCO.US>
Sent: Tuesday, January 2, 2024 5:08 PM
To: CDPHE_LOCALREFERRAL@STATE.CO.US; MARK.LAMB@STATE.CO.US; JOHN.WHITE@COLOSTATE.EDU; Justin Gutierrez <JGutierrez@Summitutilitiesinc.com>; RPARKER@ELKCREEKFIRE.ORG; RRUSH@ELKCREEKFIRE.ORG; JWARE@ELKCREEKFIRE.ORG; PLATREVIEW@LUMEN.COM; GREG.OCHIS@STATE.CO.US; ALFONZO_MARTINEZ@CABLE.COMCAST.COM; DONNA.L.GEORGE@XCELENERGY.COM; SARAH.BRUCKER@STATE.CO.US; JOANNA.WILLIAMS@STATE.CO.US; PLATREFERRAL@UNITEDPOWER.COM; CDOT_R1ACCESS_GROUPE@STATE.CO.US; BKAUFMAN@IREA.COOP; OAHF@STATE.CO.US; KIEL.G.DOWNING@USACE.ARMY.MIL
Cc: DMONKE@JEFFCO.US; MSCHUSTE@JEFFCO.US; KMILLER@JEFFCO.US
Subject: [EXTERNAL EMAIL] 23-102980RZ - ELECTRONIC REFERRAL - EXTERNAL - Rezoning



ELECTRONIC REFERRAL

This e-mail is to inform you that the application referenced below is now beginning the 2nd Referral. Please review and provide comments on the referral documents found in the [Case Folder \[jeffcogov.sharepoint.com\]](#) in the **Current Referral Documents** sub-folder. Comments should be submitted electronically to the Case Manager by the due date below.

Case Number: 23-102980 RZ

Case Type: Rezoning

Address: Shadow Mountain Bike Park, 80433

Description: Special Use Application for Development of a day-use lift-served bike park as a Class III Commercial Recreation Facility.

Case Manager: Dylan Monke

Case Manager Contact Information: dmonke@co.jefferson.co.us 303-271-8718

Comments Due: **16-JAN-24**

If you have any questions related to the processing of this application, please contact the Case Manager.

If you received this message in error, please do not read, copy, or share it. Instead, please notify the sender immediately and permanently delete all copies in your possession.



Right of Way & Permits

1123 West 3rd Avenue
Denver, Colorado 80223
Telephone: **303.571.3306**
Facsimile: 303. 571. 3284
donna.l.george@xcelenergy.com

January 10, 2024

Jefferson County Planning and Zoning
100 Jefferson County Parkway, Suite 3550
Golden, CO 80419

Attn: Dylan Monke

Re: Shadow Mountain Bike Park – 2nd referral, Case # 23-102980RZ

Public Service Company of Colorado's Right of Way & Permits Referral Desk has reviewed the second referral rezone and special use documentation for **Shadow Mountain Bike Park** and has **no apparent conflict**.

Donna George
Right of Way and Permits
Public Service Company of Colorado dba Xcel Energy
Office: 303-571-3306 – Email: donna.l.george@xcelenergy.com

Dylan Monke

From: United Power Plat Referral <platreferral@UnitedPower.com>
Sent: Thursday, January 4, 2024 3:45 PM
To: Dylan Monke
Subject: --{EXTERNAL}-- FW: 23-102980RZ - ELECTRONIC REFERRAL - EXTERNAL - Rezoning

This Message Is From an External Sender

This message came from outside your organization.

Report Suspicious

Good afternoon,

Thank you for inviting United Power, Inc. to review and comment on **23-102980 RZ- Rezoning- Shadow Mountain Bike Park, 80433**.

Unfortunately, this is outside our service territory, and we are unable to comment.

Sincerely,



500 Cooperative Way Brighton, CO 80603 [\[unitedpower.com\]](https://www.unitedpower.com)



[\[facebook.com\]](https://www.facebook.com) [\[twitter.com\]](https://www.twitter.com) [\[linkedin.com\]](https://www.linkedin.com) [\[youtube.com\]](https://www.youtube.com) [\[instagram.com\]](https://www.instagram.com)

Zayda Vargas

Right of Way Administrative Assistant

Office: 303-637-1389 | zvargas@unitedpower.com

Working Hours: Monday-Friday 8:00-4:30

United Power | www.unitedpower.com

[\[unitedpower.com\]](https://www.unitedpower.com)

500 Cooperative Way Brighton, CO 80603

*Powering Lives, Powering Change, Powering the Future—
The Cooperative Way*

From: AUTOMAILER@JEFFCO.US <AUTOMAILER@JEFFCO.US>

Sent: Tuesday, January 2, 2024 5:08 PM

To: CDPHE_LOCALREFERRAL@STATE.CO.US; MARK.LAMB@STATE.CO.US; JOHN.WHITE@COLOSTATE.EDU; JGUTIERREZ@SUMMITUTILITIESINC.COM; RPARKER@ELKCREEKFIRE.ORG; RRUSH@ELKCREEKFIRE.ORG; JWARE@ELKCREEKFIRE.ORG; PLATREVIEW@LUMEN.COM; GREG.OCHIS@STATE.CO.US; ALFONZO_MARTINEZ@CABLE.COMCAST.COM; DONNA.L.GEORGE@XCELENERGY.COM; SARAH.BRUCKER@STATE.CO.US; JOANNA.WILLIAMS@STATE.CO.US; United Power Plat Referral <platreferral@UnitedPower.com>; CDOT_R1ACCESS_GROUPE@STATE.CO.US; BKAUFMAN@IREA.COOP; OAHP@STATE.CO.US; KIEL.G.DOWNING@USACE.ARMY.MIL

Cc: DMONKE@JEFFCO.US; MSCHUSTE@JEFFCO.US; KMILLER@JEFFCO.US

Subject: 23-102980RZ - ELECTRONIC REFERRAL - EXTERNAL - Rezoning



CAUTION: This email originated from outside of United Power. Do not click links or open attachments unless you recognize the sender and know the content is safe.

ELECTRONIC REFERRAL

This e-mail is to inform you that the application referenced below is now beginning the 2nd Referral. Please review and provide comments on the referral documents found in the [Case Folder \[jeffcogov.sharepoint.com\]](#) in the **Current Referral Documents** sub-folder. Comments should be submitted electronically to the Case Manager by the due date below.

Case Number: 23-102980 RZ

Case Type: Rezoning

Address: Shadow Mountain Bike Park, 80433

Description: Special Use Application for Development of a day-use lift-served bike park as a Class III Commercial Recreation Facility.

Case Manager: Dylan Monke

Case Manager Contact Information: dmonke@co.jefferson.co.us 303-271-8718

Comments Due: **16-JAN-24**

If you have any questions related to the processing of this application, please contact the Case Manager.

Disclaimer

The information contained in this communication from the sender is confidential. It is intended solely for use by the recipient and others authorized to receive it. If you received this message in error, please contact the sender and delete the message. Any disclosure, copying, review reproduction, or distribution in relation to any of the contents of this information is strictly prohibited.

Dylan Monke

From: AUTOMAILER@JEFFCO.US
Sent: Friday, March 24, 2023 10:16 AM
To: Dylan Monke
Cc: Keith Dean
Subject: 23 102980 RZ - Agency Response

Case Number: 23 102980 RZ

Case Type: Rezoning

Case Name: Shadow Mountain Bike Park

Review: Road & Bridge

Results: Comments Sent (request re-review)

Review Comments:

Road and Bridge has no issues with the rezoning. However the traffic study does not include the impact it will have on the intersections of CR 73 and Pleasant Park Road or Barkley Road and the on and off ramp of Hwy 285(Conifer Road, S. Wolf Street, Main Street, Aspen Road). This will affect these intersections and improvements will need to be made to handle the influx in traffic.

Scheduled End Date: 04/07/2023

Reviewer: Keith Dean

Description: Special Use Application for Development of a day-use lift-served bike park as a Class III Commercial Recreation Facility.

Dylan Monke

From: AUTOMAILER@JEFFCO.US
Sent: Monday, April 10, 2023 2:39 PM
To: Dylan Monke
Cc: EOBRIEN@JEFFCO.US
Subject: 23 102980 RZ - Agency Response

Case Number: 23 102980 RZ

Case Type: Rezoning

Case Name: Shadow Mountain Bike Park

Review: Open Space

Results: No Comment (no further review)

Review Comments:

Scheduled End Date: 04/07/2023

Reviewer: Elizabeth Stoner

Description: Special Use Application for Development of a day-use lift-served bike park as a Class III Commercial Recreation Facility.

Dylan Monke

From: Hiett, Hillary <Hillary.Hiett@colostate.edu>
Sent: Wednesday, January 3, 2024 3:30 PM
To: Dylan Monke
Subject: --{EXTERNAL}-- RE: 23-102980RZ - ELECTRONIC REFERRAL - EXTERNAL - Rezoning

This Message Is From an External Sender

This message came from outside your organization.

Report Suspicious

Hi Dylan,

Regarding this case (**23-102980RZ**) CSFS has the following response:

X **The Colorado State Forest Service does not need to receive any further referrals on this case.** No site visit or forest management plan is necessary for the proposed action on this property. Either we have no concerns, or our concerns for the proposed action on this property would be addressed with the defensible space requirements of a County building permit. See additional comments below.

_____ A Wildfire Mitigation Plan (Forest Management Plan) is **NOT** necessary for the proposed action on this property. However, the **Colorado State Forest Service will need to further review this case and/or visit the site to develop specific recommendations to address wildfire hazard mitigation and/or forest health needs for the property.** A \$200 review fee must be submitted for CSFS costs associated with this further review.

_____ **A Wildfire Mitigation Plan (Forest Management Plan), prepared by an individual meeting Jefferson County standards, is recommended for this case.** A \$300 review fee must be submitted for CSFS costs associated with the review of the Plan. Please give the applicant a copy of the Jefferson County Planning & Zoning Department's **Wildfire Mitigation Plan** requirements, and have them contact the Colorado State Forest Service - Golden Field Office at 303-279-9757 to discuss plan needs.

Additional Comments: A Wildfire Hazard Mitigation Plan has already been approved for this project.

Hillary Hiett
Forester
Colorado State Forest Service
1504 Quaker Street, Golden, CO 80401
303-279-9757 ext 307
Hillary.hiett@colostate.edu
csfs.colostate.edu [csfs.colostate.edu]





COLORADO

Parks and Wildlife

Department of Natural Resources

Northeast Regional Office
6060 Broadway
Denver, CO 80216
P 303.291.7227

August 16, 2024
Attention: Dylan Monke
Jefferson County Planning & Zoning Division
100 Jefferson County Parkway, Suite 3550
Golden, CO 80419
Phone: (303) 271-8718

Re: Shadow Mountain Bike Park, Case #23-102980 RZ

Dear Dylan,

Thank you for providing Colorado Parks and Wildlife (CPW) the opportunity to comment on the Special Use Document for the proposed Shadow Mountain Bike Park development that incorporates approximately 235 acres of the 306-acre Colorado State Land Board parcel identified as ID 61-163-00-001, commonly referred to as the Shadow Mountain Parcel, in Conifer, CO. This property is located within Game Management Unit (GMU) 39 in Jefferson County, Colorado.

The mission of CPW is to perpetuate the wildlife resources of the state, to provide a quality state parks system, and to provide enjoyable and sustainable outdoor recreation opportunities that educate and inspire current and future generations to serve as active stewards of Colorado's natural resources. CPW has a statutory responsibility to manage all wildlife species in Colorado and to promote a variety of recreational opportunities throughout Colorado. One way we achieve this goal is by responding to referral comment requests.

The Shadow Mountain Parcel is approximately 305 acres of mostly contiguous undeveloped land surrounded by residential mountain development. CPW District Wildlife Managers have conducted site visits of the property and have developed many years of on-the-ground working knowledge of the wildlife values of the property. The proposed property includes a riparian corridor along the lower elevations, rocky outcroppings at higher elevations, and a series of draws in heavily wooded timber. The Shadow Mountain Parcel also plays an important role in mitigating habitat fragmentation by connecting wildlife habitat on CPW and United States Forest Service (USFS) lands to the west with wildlife habitat on Jefferson County Open Space and Denver Mountain Parks lands to the east.



Jeff Davis, Director, Colorado Parks and Wildlife

Parks and Wildlife Commission: Dallas May, Chair · Richard Reading, Vice-Chair · Karen Bailey, Secretary · Jessica Beaulieu
Marie Haskett · Jack Murphy · Gabriel Otero · Duke Phillips, IV · James Jay Tutchton · Eden Vardy

CPW appreciates the consultation because the location of this proposed project is identified as “Category 4 Crucial Big Game Habitat” whose primary threat is residential and commercial development and subsequent habitat fragmentation. Specifically, the location of the proposed project overlaps with wildlife habitat for numerous species, as described below by CPW’s Species Activity Maps:

1. Black bear overall range, fall concentration area, summer concentration area, human conflict area, and adjacent to black bear migration pattern.
2. Mountain lion overall range and human conflict area.
3. Elk overall range, summer range, winter range, winter concentration area, and adjacent to elk resident population area.
4. Mule deer overall range, resident population area, concentration area, summer range, winter range, and adjacent to mule deer winter concentration area.
5. Moose overall range, summer range, and migration pattern.

District Wildlife Managers have observed elk and mule deer use on the Shadow Mountain Parcel year round. The property is identified as summer range for elk, provides winter range habitat for bull elk, and is used by elk during the breeding season. Resident herds of elk in the area also intermittently use the property throughout the year. The property is identified as summer range for mule deer, provides connectivity to nearby winter range habitat, and mule deer have been observed using the property for fawning habitat. The riparian corridor on the property has been used increasingly by moose and is currently one of the eastern most locations where CPW receives regular moose sightings in west Jefferson County. Mountain lions, bobcats, foxes, and coyotes use the property year round. District Wildlife Managers have observed significant use by these species along the rocky outcroppings at higher elevations, and have documented coyotes denning in the same area. District Wildlife Managers have also observed regular use of the property by black bears in the area.

CPW acknowledges the developers’ inclusion of previous CPW recommendations in the proposed project’s Special Use Document, including the “Fencing,” “Trash Management,” and “Wildlife” sections of the document’s written restrictions. If development of the proposed project and associated Special Use Document were approved, CPW makes the following recommendations based on CPW-documented wildlife habitat and wildlife conflicts in this area:

1. Implement a seasonal closure on construction activity and commercial operation from January 1 through July 1 to limit disturbance on wintering and newly born wildlife.
2. Include North Turkey Creek as an identified wetland in the map contained within the Shadow Mountain Bike Park Special Use Document.
3. Prohibit all development in wetland / riparian areas to limit disturbance to wildlife movement and production areas.

CPW recognizes that there is important wildlife value in maintaining this parcel of undeveloped land and protecting it from development and regular use by human recreation, which the proposed Shadow Mountain Bike Park development would exaggerate. In an area that is becoming increasingly fragmented by a combination of development, infrastructure, traffic,

and growing recreational use of natural landscapes, the Shadow Mountain Parcel in its current undeveloped state provides habitat connectivity and refuge from human interaction that has become difficult for wildlife to find in Jefferson County.

If the timing or scope of this project changes and / or if you have additional questions regarding wildlife concerns for this property, please contact Jake Sonberg, District Wildlife Manager at jacob.sonberg@state.co.us

Sincerely,

Mark Lamb

Area Wildlife Manager, Area 1

CC: MLeslie, Region file, JSonberg, JNicholson, Area file

Dylan Monke

From: Dixon - CDOT, David <david.dixon@state.co.us>
Sent: Friday, March 24, 2023 2:33 PM
To: Dylan Monke
Subject: --{EXTERNAL}-- Re: 23-102980RZ - ELECTRONIC REFERRAL - EXTERNAL - Rezoning

This Message Is From an External Sender

This message came from outside your organization.

Report Suspicious

Good Afternoon Dylan,

This property is off the State Highway System. I have no objections or concerns. Thank you!

Very Respectfully,

David Dixon
Assistant Access Manager



720-541-0441
2829 W. Howard Pl. 2nd Floor, Denver, CO 80204
david.dixon@state.co.us | www.codot.gov [codot.gov] | www.cotrip.org [cotrip.org]

On Fri, Mar 17, 2023 at 2:38 PM <AUTOMAILER@jeffco.us> wrote:



ELECTRONIC REFERRAL

This e-mail is to inform you that the application referenced below is now beginning the 1st Referral. Please review and provide comments on the referral documents found in the [Current Referral Documents](#) sub-folder. Comments should be submitted electronically to the Case Manager by the due date below.

Case Number: 23-102980 RZ
Case Type: Rezoning
Address: Shadow Mountain Bike Park, 80433

Description: Special Use Application for Development of a day-use lift-served bike park as a Class III Commercial Recreation Facility.

Case Manager: Dylan Monke

Case Manager Contact Information: dmonke@co.jefferson.co.us 303-271-8718

Comments Due: **03/24/2023**

If you have any questions related to the processing of this application, please contact the Case Manager.



Jefferson County encrypted email system

If you received this disclaimer all email between Jefferson County and your organization is TLS encrypted.

Jefferson County Colorado

Dylan Monke

From: ColoradoES, FW6 <ColoradoES@fws.gov>
Sent: Tuesday, June 13, 2023 3:25 PM
To: Dylan Monke
Subject: --{EXTERNAL}-- RE: [EXTERNAL] FW: 23-102980 RZ - Shadow Mountain Bike Park - Request for Public Comment

This Message Is From an External Sender

This message came from outside your organization.

[Report Suspicious](#)

Hello Dylan Monke,

Thank you for contacting the U.S. Fish and Wildlife Service. The Service has reviewed your Shadow Mountain bike park project in Jefferson County and has no concerns with this project resulting in impacts to species listed as proposed, threatened, or endangered. We appreciate your efforts to ensure the conservation of threatened and endangered species.

Project Number: 2023-0081775

Respectfully,

Kyle LeMaire (he/him)
Fish and Wildlife Biologist
kyle_lemaire@fws.gov
USFWS/ES/Colorado Field Office
134 Union Blvd, Suite 670, Lakewood, CO 80228

From: Dylan Monke <dmonke@co.jefferson.co.us>
Sent: Monday, May 8, 2023 11:23 AM
To: ColoradoES, FW6 <ColoradoES@fws.gov>; george_sanmiguel@fws.gov
Subject: [EXTERNAL] FW: 23-102980 RZ - Shadow Mountain Bike Park - Request for Public Comment

This email has been received from outside of DOI - Use caution before clicking on links, opening attachments, or responding.

Hello,

We have been asked to request formal comments from the Colorado State Patrol on a recent Special Use Permit requesting a lift-served bike park on several hundred acres adjacent to Shadow Mountain Drive. I'm unclear who would be best suited in your agency to field this request, so I've started here and hope you'll forward this along to whomever might supervise that district.

Formal application documents can be reviewed here:

<https://permitsearch.jeffco.us/amandaltol/PublicDocs/Rezoning/23-102980RZ%2029611%20Shadow%20Mountain%20Drive/3.%20Review%20Process%20-%20Agency%20Comments/1st%20Referral/1%20Referral%20Documents/>

Thanks,

Dylan Monke

Jefferson County Planning and Zoning

Planner

303-271-8718

dmonke@jeffco.us | planning.jeffco.us

Beginning June 1, 2020 Jefferson County offices, including Planning and Zoning, will be open Monday through Thursday. County offices will be closed on Friday. Monday through Thursday, Planning and Zoning will have limited staff in the office due to social distancing requirements. *For the best service please schedule [appointments \[jeffco-planning-and-zoning-hqorx.appointlet.com\]](http://jeffco-planning-and-zoning-hqorx.appointlet.com) and submit [applications](#) online. Please go to planning.jeffco.us for more information.*



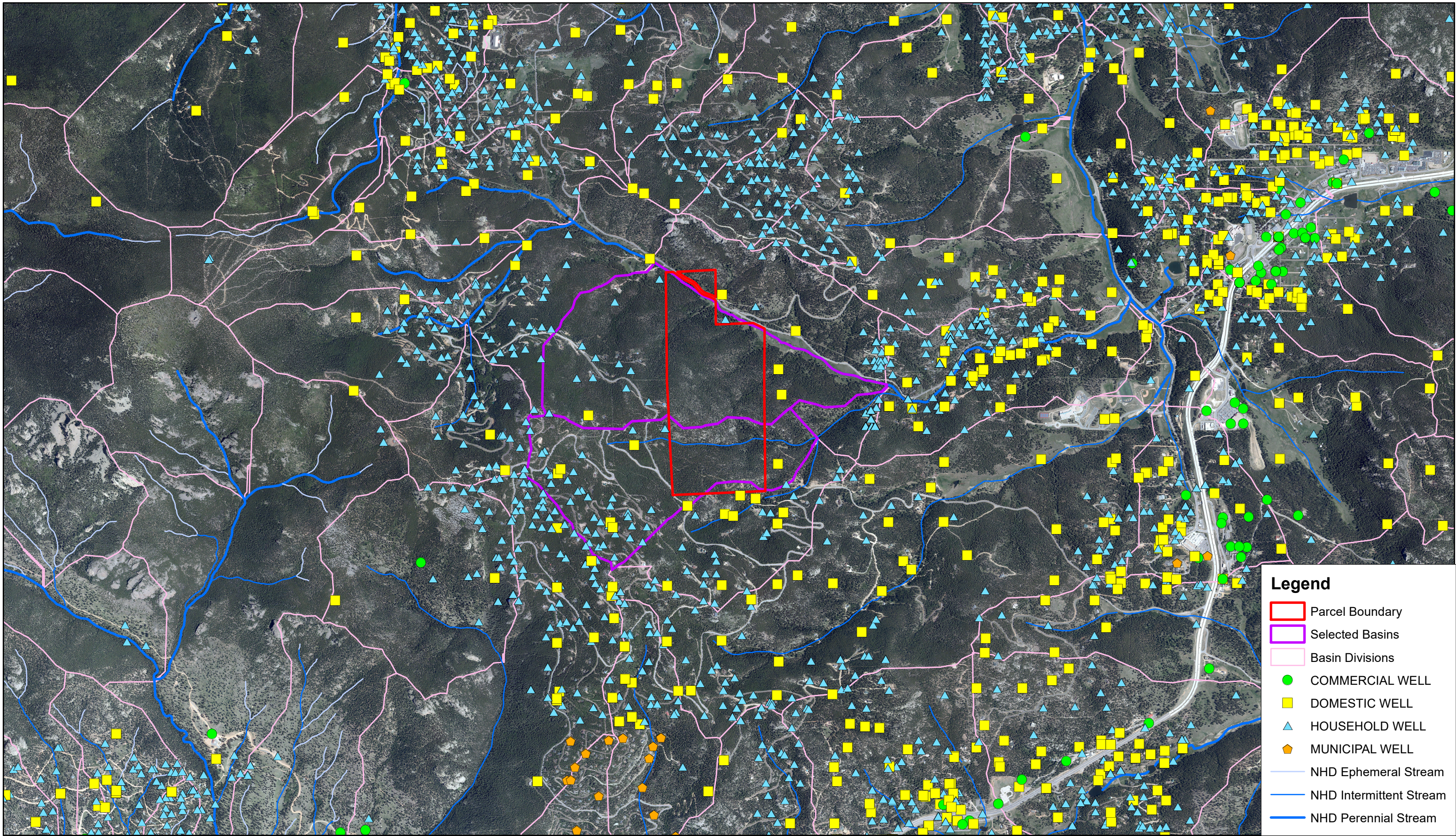

Legend

- Parcel Boundary
- Selected Basins
- Basin Divisions
- COMMERCIAL WELL
- DOMESTIC WELL
- HOUSEHOLD WELL
- MUNICIPAL WELL
- NHD Ephemeral Stream
- NHD Intermittent Stream
- NHD Perennial Stream

NOTIFICATION SUMMARY

+

PUBLIC / HOA COMMENTS

Public Comments exceed the formatting capacity of current software.

All public Comments have been added as Addendum A to this Board Packet.

CURRENT ZONING

Section 33 - Agricultural District

(orig. 3-26-13)

A. Intent and Purpose

1. The Agricultural Zone Districts are intended to provide for limited farming, ranching and agriculturally related uses while protecting the surrounding land from any harmful effects. (orig.3-26-13)
2. Contained in this section are the allowed land uses, building and lot standards (including minimum setbacks) and other general requirements for each specific agricultural zone district. (orig.3-26-13)
3. The Agricultural Zone Districts are divided as follows: (orig.3-26-13)
 - a. Agricultural-One (A-1)
 - b. Agricultural-Two (A-2)**
 - c. Agricultural-Thirty-Five (A-35)
4. A revision in March, 1972, increased the minimum land area for the Agricultural-One district to 5 acres. (orig.3-26-13)
5. A revision in March, 1972, increased the minimum land area for the Agricultural-Two district to 10 acres. (orig.3-26-13)

B. Permitted Uses (orig. 3-26-13; am. 7-17-18)

Uses	A-1	A-2	A-35
Single Family Dwelling, Barn, Stable, Silo, Corral, Pens, and Runs.	X	X	X
General Farming, including grains, fruit, vegetables, grasses, hay, livestock raising, and the keeping and boarding of horses. See general requirements below.	X	X	X
Poultry hatcheries and farms, fish hatcheries and dairy farms.	X	X	X
Greenhouse and nursery, including both wholesale and retail, provided products sold are raised on the premises.	X	X	X
Forestry farming, including the raising of trees for any purpose.	X	X	X
Fur farm and raising of rabbits, chinchillas and other similar animals.	X	X	X
Public Park, Class I public recreation facilities, Class II public recreation facilities are permitted only if the site is in compliance with the current minimum lot size requirement.	X	X	X
Veterinary hospital	X	X	X
Cemetery, mausoleum, mortuary and related uses.	X	X	X
Beekeeping operations	X	X	X
Oil and gas drilling and production subject to the Drilling and Production of Oil and Gas Section of this Zoning Resolution, except where located within a subdivision platted and recorded in the records of the Clerk and Recorder.	X	X	X
Telecommunications Land Uses shall comply with the provisions of the Telecommunications Uses Section of this Zoning Resolution.	X	X	X
Energy Conversion Systems (ECS) land uses shall comply with the provisions of the Alternative Energy Resources Section of the Zoning Resolution.	X	X	X
Water supply reservoir and irrigation canal	X	X	X

C. Accessory Uses (orig. 3-26-13; am. 7-17-18)

Uses	A-1	A-2	A-35
Accessory structures including private garage, and storage sheds	X	X	X
Roadside stand for operation during not more than 6 months in each year for the sale of farm products raised or produced on the premises, provided such stands are located no less than 30 feet distance from any street, highway, or right-of-way line.	X	X	X
Private building and kennels for housing dogs, cats or similar domestic pets. On legal non-conforming lots or parcels smaller than the minimum lot size, the maximum total number of dogs, cats and similar domesticated pets which may be kept shall be 3. Litters of puppies or kittens may be kept until weaned.	X	X	X
Temporary storage of defensible space equipment and debris associated fuel break and forest management thinning in accordance with defensible space, fuel break and forest management programs as specified in this Zoning Resolution and Land Development Regulation.	X	X	X
Home Occupations provided the requirements and conditions of the Board of Adjustment or the Home Occupations Section of this Zoning Resolution are met.	X	X	X
Accessory uses per the Accessory Use Section of the Zoning Resolution.	X	X	X

D. Special Uses (orig. 3-26-13; am. 7-17-18)

Uses	A-1	A-2	A-35
Sewage treatment plant	X	X	X
Religious Assemblies and related uses, rectory, parish house and schools.	X	X	X
Radio, television and microwave transmission and relay towers and equipment; meteorological data collection towers and equipment; low power, micro-cell and repeater telecommunications facilities, including antenna and towers.	X	X	X
Cable television reception station	X	X	X
A group living facility, other than homes for social rehabilitation, or a home where up to 6 unrelated individuals are living together, that is occupied by more than one registered sex offender.	X	X	X
Group, foster or communal home, residential treatment center, community residential home, home for social rehabilitation, assisted living residence, personal care boarding home, specialized group facility, receiving home for more than 4 foster home residents, residential child care facility or shelter from domestic violence, licensed or certified by state if applicable, in which 7 or more residents who are not legally related live and cook together as a single housekeeper unit not located within 750 ft of another similar type home or shelter.	X	X	X
State licensed daycare center or preschool or nursery.	X	X	X
Arborist or tree service	X	X	X
Natural resource transportation and conveyance systems	X	X	X
Public Kennel or cattery	X	X	X
Public riding academy or stable	X	X	X
Camps, campgrounds, picnic grounds, and lodges or other similar facilities. Specific conditions and limitations for use, including maximum periods of visitor occupancy and types or maximum numbers of occupied vehicles or sites, will be established as terms of the Special Use approval.	X	X	X
Oil and gas drilling and production, where located within a subdivision platted and recorded in the records of the Clerk and Recorder. Such operations shall conform to the standards contained in the Drilling and Production of Oil and Gas Section of the Zoning Resolution, except as modified in the resolution approving the Special Use.	X	X	X
Class I, II, III Commercial Recreational Facilities. Class II public recreational facilities on sites which do not meet the current minimum lot size requirement. Class III public recreational facilities.	X	X	X

Uses	A-1	A-2	A-35
Limited sawmill operation use in support of defensible space, associated, fuel break, forest insect and disease control, and forest management programs as required under the Zoning Resolution and Land Development Regulations.	X	X	X
Trap, skeet or rifle range		X	X
Recycling transfer station, Type I or Type II: the facility shall only accept trees and slash generated from local efforts associated with regulatory/ voluntary defensible space, fuel break and forest management plans, and Pine Beetle control programs.		X	X
Dangerous and wild animal ranching, training, sales and exhibition provided that the property is 10 acres or greater and such use is in compliance with the General Provisions and Regulations Section of this Zoning Resolution.		X	X

E. Lot and Building Standards (orig. 3-26-13; am. 7-17-18)

Districts	Front Setback		
	Primary Structure/All Garages		All Other Accessory Structures
A-1, A-2, A-35	50 ft.		Livestock – 75 ft. Pens/Runs/Structures ¹ – 100 ft. All Other Accessory Building – 50 ft.
Districts	Side Setback		
	Primary Structure/All Garages		All Other Accessory Structures
	Side	Side to Street	
A-1, A-2, A-35	30 ft.	50 ft.	Livestock – 75 ft. Pens/Runs/Structures ¹ – 100 ft. All Other Accessory Building – 50 ft.
Districts	Rear Setback		
	Primary Structure/All Garages		All Other Accessory Structures
A-1, A-2, A-35	50 ft.		50 ft.

¹ Applied to all pens, runs, and structures utilized for fur farms, poultry farms, kennels and catteries.

Districts	Building Height	Lot Size (see a & b below)
A-1	35 ft.	5 Acre (217,800 s.f.)
A-2	35 ft.	10 Acre (435,600 s.f.)
A-35	35 ft.	35 Acre (1,524,600 s.f.)

1. Lot Standards

- a. The minimum lot area for any use permitted in this district shall be the lot size stated above unless the lot falls within the provisions set forth in the Non-Conforming Lot Size provision below. (orig.3-26-13; am. 7-17-18)
- b. The minimum lot area for a lot developed through the rural cluster process shall be as set forth in the Land Development Regulation. (orig.3-26-13)

F. Fences

1. Maximum Fence Height: 7 feet. (orig.3-26-13)
2. Fences over 42 inches in height are allowed within the front setback. (orig. 7-17-18)

3. Electric fences are permitted provided the electrical fence device is in compliance with Colorado State Department of Agriculture specifications. No electric fence is allowed as boundary or perimeter fence on lot lines abutting residential zone districts. (orig.3-26-13)
4. On adjacent lots where allowed fence heights differ, the lower height restriction shall govern. (orig.3-26-13)

G. General Requirements

1. Corner lots must comply with the vision clearance triangle requirements as specified in the Definitions Section of this Zoning Resolution. (orig.3-26-13)
2. No structure may be erected placed upon or extend over any easement unless approved in writing by the agency or agencies having jurisdiction over such easement. (orig.3-26-13)

H. Animals

1. Manure shall not be allowed to accumulate so as to cause a hazard to the health, safety or welfare of humans and/or animals. The outside storage of manure in piles shall not be permitted within 100 feet of the front lot line and 50 feet of the side and rear lot lines. (orig.3-26-13)
2. Stallions shall be kept in a pen, corral or run area enclosed by a 6 foot chain link fence, or material equal or greater in strength, except when it is necessary to remove them for training, breeding or other similar purposes. (orig.3-26-13)
3. On legal non-conforming lots or parcels smaller than the minimum lot size, the following is the density per acre limitation for horses, mules, donkeys, sheep, cattle, goats, swine, buffalo, and other large domesticated animals: (orig.3-26-13; am. 7-17-18)
 - a. The minimum square footage of open lot area, available to animals, shall be 9,000 square feet for the first animal and 6,000 square feet for each additional animal. The total number of such animals that may be kept shall not exceed 4 per 1 acre. (orig.3-26-13; am. 7-17-18)
 - b. Offspring of animals on the property may be kept until weaned. (orig.3-26-13)

I. Non-conforming Lot Size

1. Planning and Zoning shall only permit the use of any unplatted Agricultural-One, Agricultural-Two, or Agricultural-Thirty-Five zoned tract or parcel that is less than 5 acres, 10 acres, or 35 acres respectively, provided that all of the following provisions are met. (orig. 9-6-77; am. 11-6-79; am. 6-16-80; am. 7-2-97; am. 12-17-02; am. 3-3-15; reloc. & am. 7-17-18)
 - a. The parcel, tract or lot existed in its current configuration prior to March 6, 1972. (orig. 9-6-77; am. 6-16-80; reloc. & am. 7-17-18)
 - b. The property is 1 acre in size or greater. (orig. 6-16-80; reloc. 7-17-18)
 - c. Use of the property shall conform with current use regulations in effect for the respective Agricultural-One, Agricultural-Two, and Agricultural-Thirty-Five Zone Districts. (orig. 9-6-77; am. 7-2-97; reloc. & am. 7-17-18)
 - d. Any new construction or structural alteration shall conform with current setback and height regulations in effect for the respective Agricultural-One, Agricultural-Two, and Agricultural-Thirty-Five Zone Districts. (orig. 9-6-77; am. 7-2-97; reloc. 7-17-18)
 - e. Requirements of Public Health for water and sanitation shall be complied with prior to the Building Permit being issued. (orig. 9-6-77; am. 12-17-02; am. 4-20-10; reloc. 7-17-18)

2. Planning and Zoning shall only permit the use of any Agricultural-One, Agricultural-Two, or Agricultural-Thirty-Five zoned lot which was platted without County approval provided that the provisions of paragraphs I.1.a through I.1.e above, are complied with. (orig. 6-16-80; am. 7-2-97; am. 12-17-02; am. 3-26-13; am. 3-3-15; reloc. & am. 7-17-18)
3. Planning and Zoning shall only permit the use of any Agricultural-One, Agricultural-Two, or Agricultural-Thirty-Five zoned lot which was platted with County approval prior to time said lot was zoned, provided that the provisions of paragraphs I.1.b. through I.1.e. above, are complied with. (orig. 6-16-80; am. 7-2-97; am. 12-17-02; am 3-26-13; am. 3-3-15; reloc. & am. 7-17-18)
4. Planning and Zoning shall only permit the use of any zoned lot which was platted with County approval subsequent to the date it was zoned provided that the provisions of paragraphs I.1.c. through I.1.e. above, are complied with. (orig. 6-16-80; am. 7-2-97; am. 12-17-02; am 3-26-13; am. 3-3-15; reloc. & am. 7-17-18)

ADDITIONAL CASE DOCUMENTS



Shadow Mountain Bike Park Sensory Impact Assessment - Noise

Final Report

March 21, 2023

Prepared for:
SE Group
323 W Main St.
Frisco CO 80443

Prepared by:
Stantec Consulting Services Inc.
733 Marquette Avenue, Suite 1000
Minneapolis, MN 55402

Project Number:
195602713

Limitations and Sign-off

The conclusions in this report Titled Shadow Mountain Bike Park Sensory Impact Assessment – Noise, are Stantec’s professional opinion, as of the time of the Report, and concerning the scope described in the Report. The opinions in the document are based on conditions and information existing at the time the scope of work was conducted and do not take into account any subsequent changes. The Report relates solely to the specific project for which Stantec was retained and the stated purpose for which the Report was prepared. The Report is not to be used or relied on for any variation or extension of the project, or for any other project or purpose, and any unauthorized use or reliance is at the recipient’s own risk.

Stantec has assumed all information received from SE Group (the “Client”) and third parties in the preparation of the Report to be correct. While Stantec has exercised a customary level of judgment or due diligence in the use of such information, Stantec assumes no responsibility for the consequences of any error or omission contained therein.

This Report is intended solely for use by the Client in accordance with Stantec’s contract with the Client. While the Report may be provided to applicable authorities having jurisdiction and others for whom the Client is responsible, Stantec does not warrant the services to any third party. The report may not be relied upon by any other party without the express written consent of Stantec, which may be withheld at Stantec’s discretion.

Prepared by: _____
Signature
Samuel Arnold, P.Eng., MAsC.
Acoustical Engineer

Printed Name and Title

Reviewed by: _____
Signature
Jacob Poling, INCE
Senior Acoustician

Printed Name and Title

Approved by: _____
Signature
JoAnne Blank
Senior Associate Scientist

Printed Name and Title



Table of Contents

Limitations and Sign-off	i
Abbreviations	iii
Executive Summary	iv
1 Introduction	1
2 Noise Terminology	2
3 Facility Description	3
4 Noise Sources	4
5 Noise Sensitive Areas	5
6 Assessment Criteria	6
7 Methodology	7
7.1 Operational Noise Analysis	7
7.2 Construction Noise Assessment	9
7.2.1 Construction Noise Mitigation	10
8 Operational Noise Assessment	11
9 Conclusion	14

List of Tables

Table 5.1: Noise Sensitive Location Summary	5
Table 6.1: Jefferson County LDR Noise Criteria ¹	6
Table 7.1: Equipment Sound Power Levels	7
Table 7.2: Modelling Assumption Summary	8
Table 7.3: Construction Noise Limits	9
Table 7.4: Construction Equipment Noise Levels ¹	9
Table 8.1: Noise Impact Summary Table – LA ₂₅ Stationary Noise Sources	11
Table 8.2: Noise Impact Summary Table – LA ₀ Stationary Noise Sources	12
Table 8.3: Noise Impact Summary Table – LA ₀ Mobile Noise Sources	13

List of Agencies

Appendix A Figures

Figure A.1	Site Location Map
Figure A.2	NSA MAP
Figure A.3	Zoning Map
Figure A.4	Daytime Stationary Noise Contours LA ₂₅ 4.5 m AG (15 ft. aG)
Figure A.5	Nighttime Stationary Noise Contours LA ₂₅ 4.5 m AG (15 ft. Ag)
Figure A.6	Daytime Stationary Noise Contours LA ₀ 4.5 m AG (15 ft. Ag)
Figure A.7	Nighttime Stationary Noise Contours LA ₀ 4.5 m AG (15 ft. Ag)
Figure A.8	Daytime Mobile Noise Contours L ₀ 4.5 M AG (15 ft. AG)



Abbreviations

dB	Decibel
dBA	Decibel (A-weighted)
GA	Ground absorption
Hz	Hertz
ISO	International Standards Organization
L_{eq}	Equivalent continuous sound level
L_0	Sound level exceeded for 0% of the time
L_{10}	Sound level exceeded for 10% of the time
L_{25}	Sound level exceeded for 25% of the time
L_{50}	Sound level exceeded for 50% of the time
L_{90}	Sound level exceeded for 90% of the time
L_{max}	Maximum sound level
L_{min}	Minimum sound level
LDR	Land Development Regulations
SIA	Sensory Impact Assessment
SLM	Sound level meter
SMBP	Shadow Mountain Bike Park



Executive Summary

The SE Group has retained Stantec Consulting Services Inc. (Stantec) to complete a Sensory Impact Assessment (SIA) to evaluate noise impacts generated by the proposed Shadow Mountain Bike Park (SMBP). The proposed location of the SMBP is along Shadow Mountain Drive in Conifer, Jefferson County, Colorado (the Site). The proposed SMBP will consist of a downhill mountain bike park with lift services, 320 parking spaces, a day lodge building, and a maintenance building.

This SIA was completed in accordance with the requirements of the Jefferson County Colorado Land Development Regulation (LDR), amended December 6, 2022, which requires that proposed Developments not create sensory impacts including noise, odor, and visual impacts at nearby sensitive receptors such as parks, schools, or residential buildings. The scope of this SIA is limited to the evaluation of the impacts of noise resulting from the operation of the proposed SMBP only.

Operational noise from the SMBP was modelled using CADNA/A acoustic modelling software (version 2021 MR2) published by Datakustik GmbH, configured to implement ISO-9613-2 environmental noise propagation algorithms. Operational noise sources from Stantec's database were used for this assessment as final equipment selections and final design of the SMBP have yet to be completed at the time of writing of this report.

Stantec recommends that this study be updated when final design of the SMBP is complete to validate the assumptions of this SIA.

Predicted sound levels indicate that the noise generated by the proposed SMBP at nearby noise sensitive areas and highest impacted/worst case property line locations is below the applicable daytime and nighttime noise limits for nearby residential receptors. The results of this SIA demonstrate that the SMBP is expected to comply with the Jefferson County LDR noise limits.



1 Introduction

The SE Group has retained Stantec Consulting Services Inc. (Stantec) to complete a Sensory Impact Assessment (SIA) to evaluate noise impacts generated by the Shadow Mountain Bike Park (SMBP). The proposed location of the SMBP is along Shadow Mountain Drive in Conifer, Jefferson County, Colorado (The Site). The proposed SMBP will consist of a downhill mountain bike park with lift services, 320 parking spaces, a day lodge building, and a maintenance building.

This SIA was prepared in accordance with Section 26 of the Jefferson County Land Development Regulations (LDR) amended December 6, 2022.

Figure A.1 included in **Appendix A** shows the location of the Site.



2 Noise Terminology

Sound is caused by vibrations that generate waves of minute pressure fluctuations in the surrounding air. Sound levels are measured using a logarithmic decibel (dB) scale. Human hearing varies in sensitivity for different sound frequencies, and the frequency sensitivity changes based on the overall sound level. The ear is most sensitive to sound at frequencies between 800 and 8,000 hertz (Hz) and is least sensitive to sound at frequencies below 400 Hz or above 12,500 Hz. Consequently, several different frequency weighting schemes have been used to approximate the way the human ear responds to various frequencies at different sound levels. The A-weighted decibel, or dBA, scale is the most widely used for regulatory requirements, as it discriminates against low frequency noise similar to the response of the human ear at the low to moderate sound levels typical of environmental sources. Sound levels without a frequency weighting applied, referred to as unweighted or linear, are generally reported as dB or dBZ.

The sound power level (PWL or L_w) of a noise source is the strength or intensity of noise that the source emits regardless of the environment in which it is placed. Sound power is a property of the source, and therefore is independent of distance. The radiating sound power then produces a sound pressure level (SPL or L_p) at a point of which human beings can perceive as audible sound. The sound pressure level is dependent on the acoustical environment (e.g., indoor, outdoor, absorption, reflections) and the distance from the noise source. Unless otherwise stated, sound levels in this report are sound pressure levels.

Numerous metrics and indices have been developed to quantify the temporal characteristics (changes over time) of community noise. The equivalent continuous sound level, L_{eq} , metric is the level of a hypothetical steady sound that would have the same energy as the fluctuating sound level over a defined period of time. The L_{eq} represents the time average of the fluctuating sound pressure level. The maximum and minimum sound levels, or L_{max} and L_{min} , are the loudest and quietest instantaneous sound levels occurring during a period of time. The L_{max} is particularly useful for evaluating loud, impulsive noise events.

Other statistical metrics useful to understanding environmental sound levels include the n-percent exceedance sound percentile levels, or L_n . This report includes the L_{25} metric, or the noise level that is exceeded 25% of the time and the L_0 which is the sound level exceeded 0% of the time. The L_0 can be considered equivalent to the L_{max} or maximum sound level. The L_{10} can be approximated as the sound level between L_{max} and L_{25} .

A change in sound levels of 3 decibels is generally considered to be the threshold of perception, whereas a change of 5 decibels is clearly perceptible, and a change of 10 decibels is perceived as a doubling or halving of loudness.



3 Facility Description

The proposed SMBP will consist of a four-passenger chairlift to transport guests and bikes to the top terminal area for gravity flow and downhill trails. The SMBP will operate during daytime hours, as defined by Section 26 of the Jefferson County LDR, between 7 a.m. to 7 p.m. The chairlift will require one terminal in the base area and the terminal area at the top of Shadow Mountain. Chairlift construction will require a 40-foot-wide corridor to accommodate the associated infrastructure. The corridor will be cleared during the construction phase of the project. The chairlift will require power at the bottom and top terminal areas as well as communication lines along the lift infrastructure.

The SMBP will provide approximately 16 miles of trails with varying levels of difficulty. Trails will be constructed of earth, wood, steel, and other materials. All trails will be setback a minimum of 50 feet from property lines.

Parking for approximately 300 guest vehicles will be provided near the base area using the access road along Shadow Mountain Drive. A day lodge will be constructed in the base area of the SMBP to provide guest services including indoor seating, ticketing, restrooms, changing rooms, bike and equipment rentals, and outdoor guest space and seating. Water will be supplied by a commercial water well and sewage will be handled by an onsite wastewater system.

There will be no permanent kitchen space in the day lodge. To address the food and beverage needs of guests, food truck vendors will be brought on site during operational hours.

A maintenance building will be constructed along the maintenance access road for facility operations. Parking for approximately 20 employees will be provided adjacent to the maintenance building.



4 Noise Sources

Based on the facility description, the primary sources of noise from the SMBP are assumed to be the following:

- Chairlift terminals at the base area and top of Shadow Mountain.
- HVAC equipment at the day lodge, maintenance building, and chairlift buildings.
- Vehicle noise from movements in the parking lot.
- Vehicle noise along the maintenance road from the maintenance shop to the mountain top.
- Speakers near the day lodge outside dining area.
- A food truck idling adjacent to the day lodge.

The primary noise sources expected to operate at the proposed SMBP are consistent with the definition of steady state or quasi steady state impulsive sound. Steady state or quasi steady state impulsive sound can generally be defined as a sequence of impulsive sound emitted from the same source having a time interval of less than 0.5 seconds between successive impulsive sounds. Impulsive sound can be generally defined as a single pressure pulse or a single burst of pressure pulses with a time interval of equal or greater than 0.5 seconds. Examples of impulsive sound can include dump truck gate banging or impact pile driver operation.

Other potential sources of noise on site such as human or electric powered mountain bikes travelling along the proposed SMBP trails or noise along the chairlift line are assumed to have an insignificant impact to nearby sensitive noise receptors.



5 Noise Sensitive Areas

Noise sensitive areas (NSAs) were identified around the SMBP based on a review of satellite imagery and zoning. Thirteen NSA locations were selected to evaluate the noise impact from steady state noise SMBP sources at residences. Five (5) additional locations were selected near the property lines of the Site as representative worst-case locations. Property line locations were assessed 25 feet from the property limits of the proposed SMBP consistent with the evaluation requirements of the Jefferson County LDR. A summary of NSAs is provided in **Table 5.1**. A location map of NSAs is included as **Figure A.2** in **Appendix A**. A zoning map for the area surrounding the site is included as **Figure A.3** in **Appendix A**.

Table 5.1: Noise Sensitive Location Summary

Noise Sensitive Area ID	Description and Approximate Street Address ¹	UTM NAD 83 Coordinates		
		Zone	Easting	Northing
NSA01	Residence at 30812 Shadow Mountain Drive	13S	469462	4376303
NSA02	Residence at 10188 Christopher Drive	13S	469795	4375463
NSA03	Residence at 10178 Christopher Drive	13S	469781	4375299
NSA04	Residence at 10218 Christopher Drive	13S	469621	4375781
NSA05	Residence at 29795 Kennedy Gulch Road	13S	470473	4374826
NSA06	Residence at 30241 Shadow Mountain Drive	13S	470491	4376172
NSA07	Residence at 29611 Shadow Mountain Drive	13S	470742	4375981
NSA08	Residence at 29365 Kennedy Gulch Road	13S	471070	4375165
NSA09	Residence at 30772 Shadow Mountain Drive	13S	469711	4376453
NSA10	Residence at 30192 Shadow Mountain Drive	13S	470205	4376076
NSA11	Residence at 29455 Kennedy Gulch Road	13S	470684	4374893
NSA12	Residence at 29405 Kennedy Gulch Road	13S	470988	4374980
NSA13	Residence at 29152 Shadow Mountain Drive	13S	471269	4375568
NSA14	25 ft. from West Property Line	13S	469810	4375391
NSA15	25 ft. from North Property Line	13S	470170	4376056
NSA16 ²	50 ft. from Northeast Property Line	13S	470456	4376057
NSA17	25 ft. from East Property Line	13S	470525	4375820
NSA18	25 ft. from East Property Line	13S	470523	4375937

¹ All residences conservatively assumed to be two-story residences. Property line assessment height assumed to be one story.

² NSA16 has been assessed at approximately 50 ft. from the northeast property line as 25 ft. from the northeast property line is in the center of Shadow Mountain Drive within the public right-of-way. The assessment point at 50 ft. from the northeast property line is located along a pathway which is more representative of a noise sensitive assessment location.



6 Assessment Criteria

The December 6, 2022, revision of the Jefferson County, Colorado LDR regulates the development of lands in the County with consideration given to protecting land, environment, and natural resources. Section 26 of the LDR regulates sensory impacts from a Development which can include noise, odor, and visual impacts. This assessment is limited to assessing the noise impact of the proposed SMBP.

The applicable criteria for the project under Section 4, Subsection A is:

“Noise generated from the proposed development shall not exceed the dBA levels set forth in Section 25-12-103, C.R.S. or as may be amended from time to time. The dBA levels are depicted in the dBA Table: (reloc. 7-12-05; am. 4-4-06)”

The table referenced in the LDR is provided as **Table 6.1**.

Table 6.1: Jefferson County LDR Noise Criteria¹

dBA Table					
Time	7 a.m. to 7 p.m.	7 a.m. to 7 p.m.	7 a.m. to 7 p.m.	7 p.m. to 7 a.m.	7 p.m. to 7 a.m.
Frequency	L ₂₅	L ₀	Periodic/Impulsive	L ₀	Periodic/Impulsive
Park/School, Residential	55	65	50	50	45
Commercial	60	70	55	55	50
Light Industrial	70	80	65	65	60
Industrial	80	90	75	75	70

¹ Source Jefferson County Colorado Land Development Regulation December 2022

The area surrounding the proposed SMBP is zoned primarily residential or agricultural with existing residences. Stantec has adopted the steady state (i.e., non-periodic/impulsive) noise limits for residential areas and property line evaluation locations for this assessment. The applicable limits for residential areas are L₂₅ of 55 dBA or L₀ of 65 dBA during daytime hours and L₀ of 50 dBA during nighttime hours for steady state noise sources measured 25 ft. from the property limits of the SMBP.

The SMBP is not expected to have any significant sources of periodic or impulsive noise and operations will be limited to daytime hours only, with the exception of HVAC units. The L₁₀ noise level of a noise source can typically be estimated by adding 3 dBA to the LA_{eq} noise level¹ and, by definition, the L₂₅ noise level for a piece of equipment will be lower than the L₁₀ noise level. For this study, the L₂₅ noise level was conservatively estimated by adding a 3 dBA correction factor to modelled LA_{eq} noise levels. The L₀ noise level, which is higher than both the L₁₀ and L₂₅, was conservatively estimated by adding a 6 dBA correction factor to modelled LA_{eq} noise levels.

¹ Federal Highway Administration Roadway Construction Noise Model (RCNM) User's Guide. January 2006.



7 Methodology

7.1 Operational Noise Analysis

The proposed SMBP will include several sources of steady state noise as described in **Section 4**. As final equipment selections have not been completed at the time of writing of this report, Stantec has selected representative sound power levels to model the predicted impact of the SMBP.

The representative equipment sound power levels used in the analysis are summarized in **Table 7.1**.

Table 7.1: Equipment Sound Power Levels

Equipment Type	Type	Octave Band Sound Power Level (dB)									Total Sound Power Level (dBA)
		31.5 Hz	63 Hz	125 Hz	250 Hz	500 Hz	1,000 Hz	2,000 Hz	4,000 Hz	8,000 Hz	
Chair Lift Terminal	Leq	73	78	93	90	93	88	96	83	78	98
Vehicle Passby	Lmax	64	59	65	58	55	54	50	45	40	90
HVAC Unit	Leq	85	86	82	78	76	73	69	64	56	78
Truck Idle	Leq	30	94	96	94	88	85	81	78	74	91
Speaker	Leq	86	93	91	86	90	95	91	87	81	98



Table 7.2 summarizes the modelling assumptions used for equipment quantities, operating parameters including speed and operating time, and other modelling parameters.

Table 7.2: Modelling Assumption Summary

Equipment Type	Quantity	Operation Time	Operational Notes
Chair Lift Terminal	2	7 a.m. to 7 p.m.	Operations at the top terminal area and at the base terminal area. Operating continuously during daytime hours only. Top terminal area to be located 150 ft. from west property line.
Transport Truck	1	7 a.m. to 7 p.m.	One truck per hour along the maintenance road connecting the top terminal to the maintenance building. Speed assumed to be 10 mph and operating during daytime hours only.
HVAC Unit	6	24-hour operation	One HVAC unit at the top terminal chairlift, one at the bottom terminal chairlift, two at the day lodge building, and two at the maintenance building. All operating continuously over a 24-hour period
Truck Idle	1	7 a.m. to 7 p.m.	One food truck idling along the southwest side of the lodge building operating continuously during daytime hours only.
Speaker	1	7 a.m. to 7 p.m.	One speaker adjacent to the outdoor seating area at the southwest side of the lodge building operating continuously during daytime hours only
Vehicle Parking Noise	241	7 a.m. to 7 p.m.	A worst case 241 vehicles per hour entering and exiting the site in the parking lot area has been assumed.

Noise modeling was completed using the Datakustik CadnaA environmental noise modeling software. The operational noise modeling followed typical modeling standards, input parameters, and assumptions, namely:

- The ISO 9613-2 standard² algorithm for outdoor sound propagation was used.
- Ground absorption factor of G=0.8 was used.
- Ground elevations were included in the model using equal height contour lines.
- Meteorology parameters were set to 10 degrees Celsius and 70 percent relative humidity.
- Receptor height of 4.5 m (15 ft.) to be representative of a two-storey residence.
- No sound attenuation from vegetation (foliage) to simulate a worst-case condition when leaves have fallen off trees.
- Meteorological conditions are conducive to sound propagation with all receptors located downwind of all noise sources.

² ISO 9613-2: 1996. Acoustics – Attenuation of sound during propagation outdoors. Part 2: General method of calculation.



7.2 Construction Noise Assessment

Construction activities related to the Development of the proposed SMBP will occur in phases and generally consist of site preparation including tree clearing and road construction, installation of the chair lift, construction of the lodge, and installation of utilities. Construction activities will typically be limited to daytime only.

In accordance with the Jefferson County Regulatory Policy – Noise Abatement adopted April 24, 2007 (“Policy No. Part 3, Regulations, Chapter 1, Noise, Section 1”) construction activities are subject to the noise limits summarized in **Table 7.3**.

Table 7.3: Construction Noise Limits

Time Period	Limits ¹
7 a.m. to 7 p.m.	80 dB(A)
7 p.m. to 7 a.m.	75 dB(A)

¹ Noise limits are applicable 25 ft. from the property line of the Development.

At this stage of the proposed SMBP development, detailed construction phasing including equipment selections and timelines have not been finalized. In general, noise impacts from construction equipment will vary by type, age of equipment, overall condition, and operators. During construction of the proposed SMBP, noise from construction activities may be audible at nearby sensitive receptors; however, not all construction equipment required for the construction of the SMBP will be operating at the same time. Additionally, activities will be spread across the Project area and be temporary in duration which will reduce the overall noise impact of construction activities.

The minimum setback distance of noise sensitive areas identified in **Section 5** is approximately 200 feet from major project components such as the chairlift, parking lot, and day lodge. A summary of representative noise levels for anticipated construction equipment is provided in Table 7.4 at 50 ft. Maximum sound levels from equipment is expected to be below the applicable construction noise limits identified in **Table 7.3**; however, Stantec recommends that the construction equipment list and setback distances be reviewed and confirmed prior to construction.

Table 7.4: Construction Equipment Noise Levels¹

Equipment	Noise Level at 50 feet from Source (dBA L _{max})	Noise Level at 200 feet from Source (dBA L _{max})
Bulldozer	85	73
Crane	85	73
Chainsaw	85	73
Excavator	81	69
Front end loader	79	67
Concrete batch plant	83	71
Drill Rig Truck	79	67



Equipment	Noise Level at 50 feet from Source (dBA L _{max})	Noise Level at 200 feet from Source (dBA L _{max})
Grader	85	73
Haul/Dump Truck	84	72
Flat Bed Truck	74	62
Pneumatic Tools	85	73
Backhoe	80	68

¹ Source: Federal Highway Administration Roadway Construction Noise Model (RCNM) User's Guide. January 2006.

7.2.1 Construction Noise Mitigation

Construction noise is typically mitigated by implementing best practices such as ensuring construction equipment and associated mufflers are in good working order, limiting the loudest construction activities to daytime hours, using alternative quieter construction methods and/or scheduling work to minimize concurrent use of the loudest equipment, and establishing a noise complaint resolution process. Placement of noise barriers around work sites can be considered for activities in the near vicinity of noise-sensitive land uses.



8 Operational Noise Assessment

Operational noise modelling was completed for the proposed SMBP with the modelling assumptions and methodology outlined in **Section 7.1**. With the exception of HVAC equipment, on-site noise sources will operate during daytime hours only. Due to the varying nature of vehicle passbys as they travel along a modelled path, Stantec has conservatively evaluated vehicle passbys using the LA₀ noise metric. As all other sources of noise are stationary, they have been evaluated using the LA₂₅ noise metric.

Predicted project-generated noise levels at the noise sensitive areas and property lines are summarized in **Table 8.1** and **Table 8.2** for stationary noise sources. Predicted project-generated noise levels at the noise sensitive areas and representative property line locations are summarized in **Table 8.3** for mobile noise sources. Mobile noise source impacts were evaluated as a result of vehicle passbys along the maintenance road and parking lot. The LA₂₅ is the noise level exceeded 25 percent of the time and the LA₀ is the maximum noise level.

Table 8.1: Noise Impact Summary Table – LA₂₅ Stationary Noise Sources

Noise Sensitive Area ID	Description	Daytime Project Noise Level (LA ₂₅ dBA) ¹	Nighttime Project Noise Level (LA ₂₅ dBA) ¹	Day Limit (LA ₂₅ dBA) ¹	Night Limit (LA ₂₅ dBA) ¹	Complies with Limits?
NSA01	Residence at 30812 Shadow Mountain Drive	25	13	55	-	Yes
NSA02	Residence at 10188 Christopher Drive	50	31	55	-	Yes
NSA03	Residence at 10178 Christopher Drive	41	24	55	-	Yes
NSA04	Residence at 10218 Christopher Drive	32	20	55	-	Yes
NSA05	Residence at 29795 Kennedy Gulch Road	22	10	55	-	Yes
NSA06	Residence at 30241 Shadow Mountain Drive	45	27	55	-	Yes
NSA07	Residence at 29611 Shadow Mountain Drive	40	23	55	-	Yes
NSA08	Residence at 29365 Kennedy Gulch Road	27	13	55	-	Yes
NSA09	Residence at 30772 Shadow Mountain Drive	31	20	55	-	Yes
NSA10	Residence at 30192 Shadow Mountain Drive	45	33	55	-	Yes
NSA11	Residence at 29455 Kennedy Gulch Road	27	14	55	-	Yes
NSA12	Residence at 29405 Kennedy Gulch Road	26	12	55	-	Yes
NSA13	Residence at 29152 Shadow Mountain Drive	31	16	55	-	Yes
NSA14	25 ft. from West Property Line	55	36	55	-	Yes
NSA15	25 ft. from North Property Line	44	34	55	-	Yes
NSA16	50 ft. from Northeast Property Line	53	32	55	-	Yes
NSA17	25 ft. from East Property Line	50	31	55	-	Yes
NSA18	25 ft. from East Property Line	53	31	55	-	Yes

¹ LA₂₅ estimated based on LA_{eq} sound level with +3 dBA correction factor.



Shadow Mountain Bike Park Sensory Impact Assessment - Noise

8 Operational Noise Assessment

March 21, 2023

Table 8.2: Noise Impact Summary Table – LA₀ Stationary Noise Sources

Noise Sensitive Area ID	Description	Daytime Project Noise Level (LA ₀ dBA) ¹	Nighttime Project Noise Level (LA ₀ dBA) ¹	Day Limit (LA ₀ dBA) ¹	Night Limit (LA ₀ dBA) ¹	Complies with Limits?
NSA01	Residence at 30812 Shadow Mountain Drive	27	16	65	50	Yes
NSA02	Residence at 10188 Christopher Drive	53	34	65	50	Yes
NSA03	Residence at 10178 Christopher Drive	44	27	65	50	Yes
NSA04	Residence at 10218 Christopher Drive	34	23	65	50	Yes
NSA05	Residence at 29795 Kennedy Gulch Road	24	12	65	50	Yes
NSA06	Residence at 30241 Shadow Mountain Drive	48	30	65	50	Yes
NSA07	Residence at 29611 Shadow Mountain Drive	43	26	65	50	Yes
NSA08	Residence at 29365 Kennedy Gulch Road	30	15	65	50	Yes
NSA09	Residence at 30772 Shadow Mountain Drive	34	23	65	50	Yes
NSA10	Residence at 30192 Shadow Mountain Drive	48	36	65	50	Yes
NSA11	Residence at 29455 Kennedy Gulch Road	29	15	65	50	Yes
NSA12	Residence at 29405 Kennedy Gulch Road	29	14	65	50	Yes
NSA13	Residence at 29152 Shadow Mountain Drive	33	18	65	50	Yes
NSA14	25 ft. from West Property Line	58	38	65	50	Yes
NSA15	25 ft. from North Property Line	46	36	65	50	Yes
NSA16	50 ft. from Northeast Property Line	54	35	65	50	Yes
NSA17	25 ft. from East Property Line	53	34	65	50	Yes
NSA18	25 ft. from East Property Line	54	34	65	50	Yes

¹ LA₀ estimated based on LA_{eq} sound level with +6 dBA correction factor.



Table 8.3: Noise Impact Summary Table – LA₀ Mobile Noise Sources

Noise Sensitive Area ID	Description	Daytime Project Noise Level (LA ₀ dBA) ¹	Nighttime Project Noise Level (LA ₀ dBA) ¹	Day Limit (LA ₀ dBA) ¹	Night Limit (LA ₀ dBA) ¹	Complies with Limits?
NSA01	Residence at 30812 Shadow Mountain Drive	20	-	65	50	Yes
NSA02	Residence at 10188 Christopher Drive	49	-	65	50	Yes
NSA03	Residence at 10178 Christopher Drive	39	-	65	50	Yes
NSA04	Residence at 10218 Christopher Drive	28	-	65	50	Yes
NSA05	Residence at 29795 Kennedy Gulch Road	27	-	65	50	Yes
NSA06	Residence at 30241 Shadow Mountain Drive	35	-	65	50	Yes
NSA07	Residence at 29611 Shadow Mountain Drive	31	-	65	50	Yes
NSA08	Residence at 29365 Kennedy Gulch Road	19	-	65	50	Yes
NSA09	Residence at 30772 Shadow Mountain Drive	27	-	65	50	Yes
NSA10	Residence at 30192 Shadow Mountain Drive	46	-	65	50	Yes
NSA11	Residence at 29455 Kennedy Gulch Road	26	-	65	50	Yes
NSA12	Residence at 29405 Kennedy Gulch Road	20	-	65	50	Yes
NSA13	Residence at 29152 Shadow Mountain Drive	20	-	65	50	Yes
NSA14	25 ft. from West Property Line	52	-	65	50	Yes
NSA15	25 ft. from North Property Line	56	-	65	50	Yes
NSA16	50 ft. from Northeast Property Line	56	-	65	50	Yes
NSA17	25 ft. from East Property Line	38	-	65	50	Yes
NSA18	25 ft. from East Property Line	54	-	65	50	Yes

¹ LA₀ estimated based on LA_{eq} sound level with +6 dBA correction factor.

The above tables demonstrate that Project sound levels are predicted to be below the applicable daytime and nighttime noise criteria at all nearby existing sensitive receptors and 25 feet from the property line of the SMBP for NSA14, NSA15, NSA17, and NSA18.

The noise level at NSA16, representing the northeast property line, was assessed using a setback distance of 50 ft. rather than 25 ft. The location that is 25 ft. from the property line is situated at the center of Shadow Mountain Drive, which is not a noise sensitive location. The 50 ft. setback distance situates NSA16 along the pathway on the north side of Shadow Mountain drive which is a more representative noise sensitive location.

Stationary sound level contours at 15 feet above ground are presented in **Figure A.4** and **Figure A.5** for LA₂₅ noise levels and **Figure A.6** and **Figure A.7** for L₀ noise levels in **Appendix A**. Mobile sound level contours at 15 ft above ground from vehicle passbys are presented as **Figure A.8** in **Appendix A**. The sound level contours illustrate how sound is expected to propagate in the area surrounding the Project and account for the effects of local site topography. The sound level contours further show that Project noise levels are below the applicable limits at nearby receptors and at locations 25 feet from the property line of the proposed SMBP.



9 Conclusion

This sensory impact assessment was completed to evaluate the noise impact of the proposed Shadow Mountain Bike Park the Jefferson County Land Development Regulations. An operational noise model was developed and used to predict the noise impacts of proposed equipment on the Site.

The results of the noise modelling for operational noise predict that noise levels at the nearby sensitive noise receivers will comply with the Jefferson County requirements.

Additionally, construction noise impacts from equipment predicted to be required for the construction of the Shadow Mountain Bike Park are expected to be below the applicable construction noise limits.

This assessment was completed using the preliminary site layout and equipment locations provided by the SE group. Locations of equipment and equipment selection may change and additional construction equipment, not considered in this assessment, such as impact pile drivers may be required during construction. Stantec recommends that this study be updated when final design is completed to evaluate compliance with applicable noise criteria and validate the assumptions made for this assessment.



Appendices



Appendix A Figures





- Legend
- Site Limits
 - Site Limits (2km buffer)

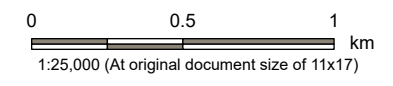

- Notes
1. Coordinate System: NAD 1983 UTM Zone 13N
 2. Base features produced under creative commons license with the Colorado Department of Transportation © 2022.
 3. Orthoimagery © 2024 Microsoft Corporation © 2024 Maxar © CNES (2024) Distribution Airbus DS

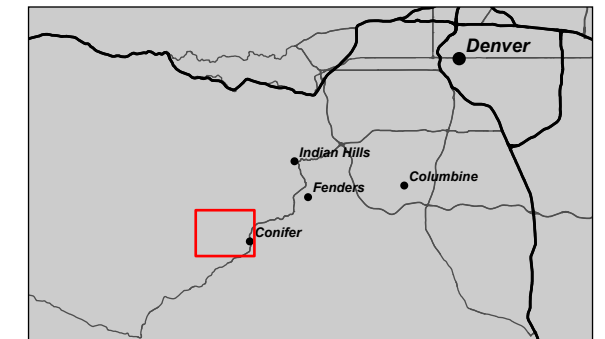

Project Location: 181711248 REVA
 Jefferson County, CO Prepared by MDA on 2024-03-20
 Technical Review by BCC on 2023-11-30

Client/Project
 SE Group
 Shadow Mountain Sensory Impact Study - Noise

Figure No.
A.1

Title
Site Plan

\va0004-ppes\work_group\01609\active_Other_POC_Active_009_G0181711248\03_data\figs\emr\noise\report_figures\noise_181711248_noise_is_spr\181711248_fig01_SitePlan_Reviewed: 2024-03-20 By: malcazaren





470000

471000



Legend

-  Site Limits
-  Noise Receptor

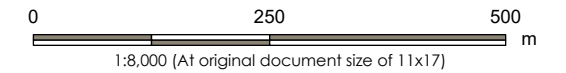

- Notes**
1. Coordinate System: NAD 1983 UTM Zone 13N
 2. Base features produced under creative commons license with the Colorado Department of Transportation © 2022.
 3. Orthoimagery © 2024 Microsoft Corporation © 2024 Maxar © CNES (2024) Distribution Airbus DS

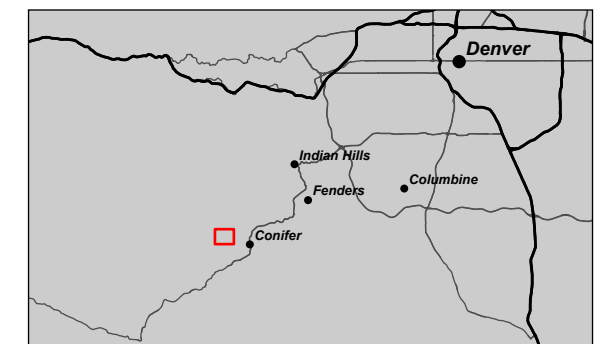

Project Location: Jefferson County, CO
 Prepared by MDA on 2024-03-20
 Technical Review by BCC on 2023-11-30

Client/Project: SE Group
 Shadow Mountain Sensory Impact Study - Noise

Figure No.: **A.2**
 Title: **Noise Source Plan**

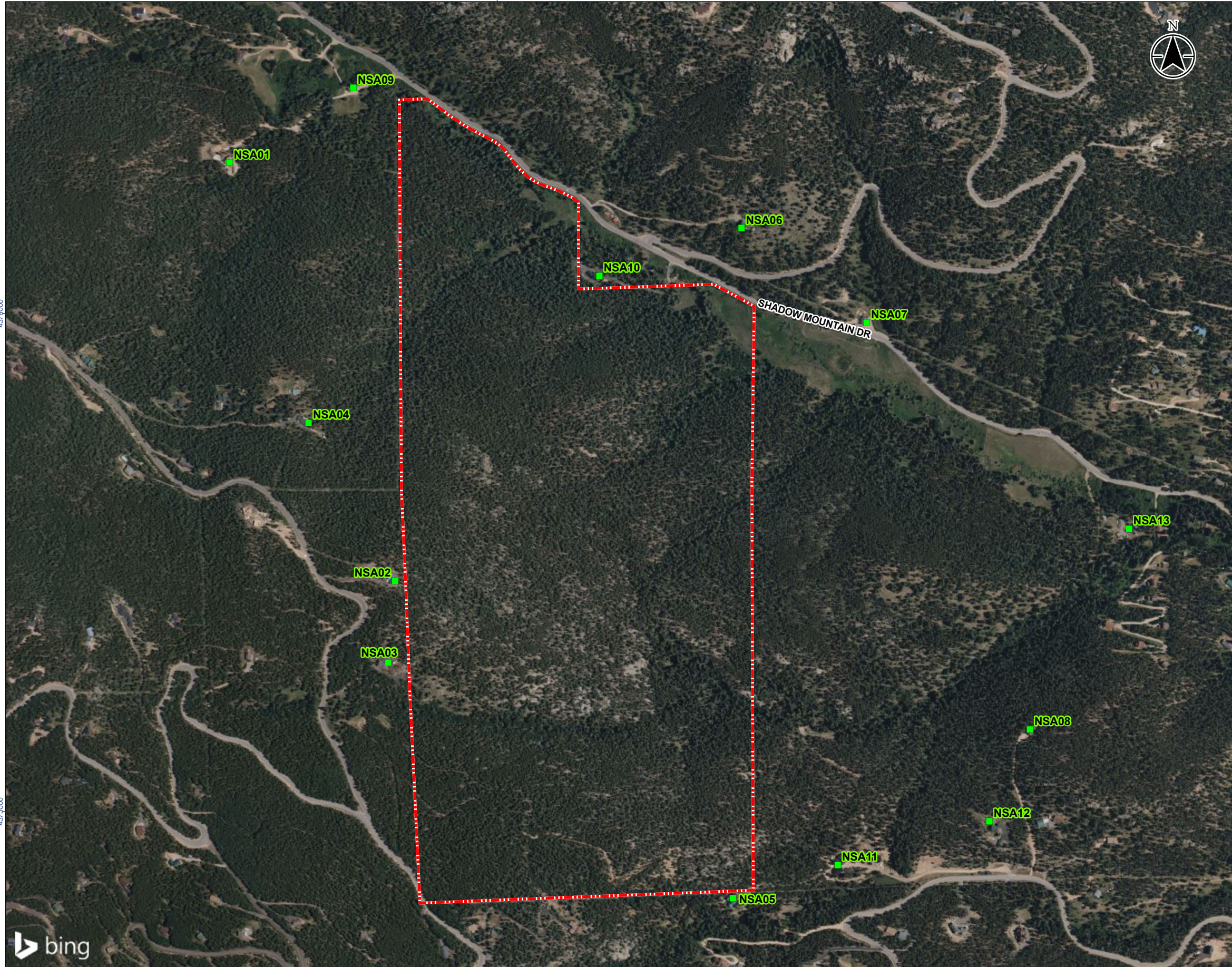

470000

471000



\\va0004-ppes\work_group\01609\active_Other_POC_Active\009_GIS\181711248\03_data\gis_cad\gis_md\noise\report_figures\noise_181711248_noise_181711248_fig02_NSPlan_Review_2024-03-20_By:malcazaren

Disclaimer: Stantec assumes no responsibility for data supplied in electronic format. The recipient accepts full responsibility for verifying the accuracy and completeness of the data. The recipient releases Stantec, its officers, employees, consultants and agents, from any and all claims arising in any way from the content or provision of the data.

Jefferson County, Colorado

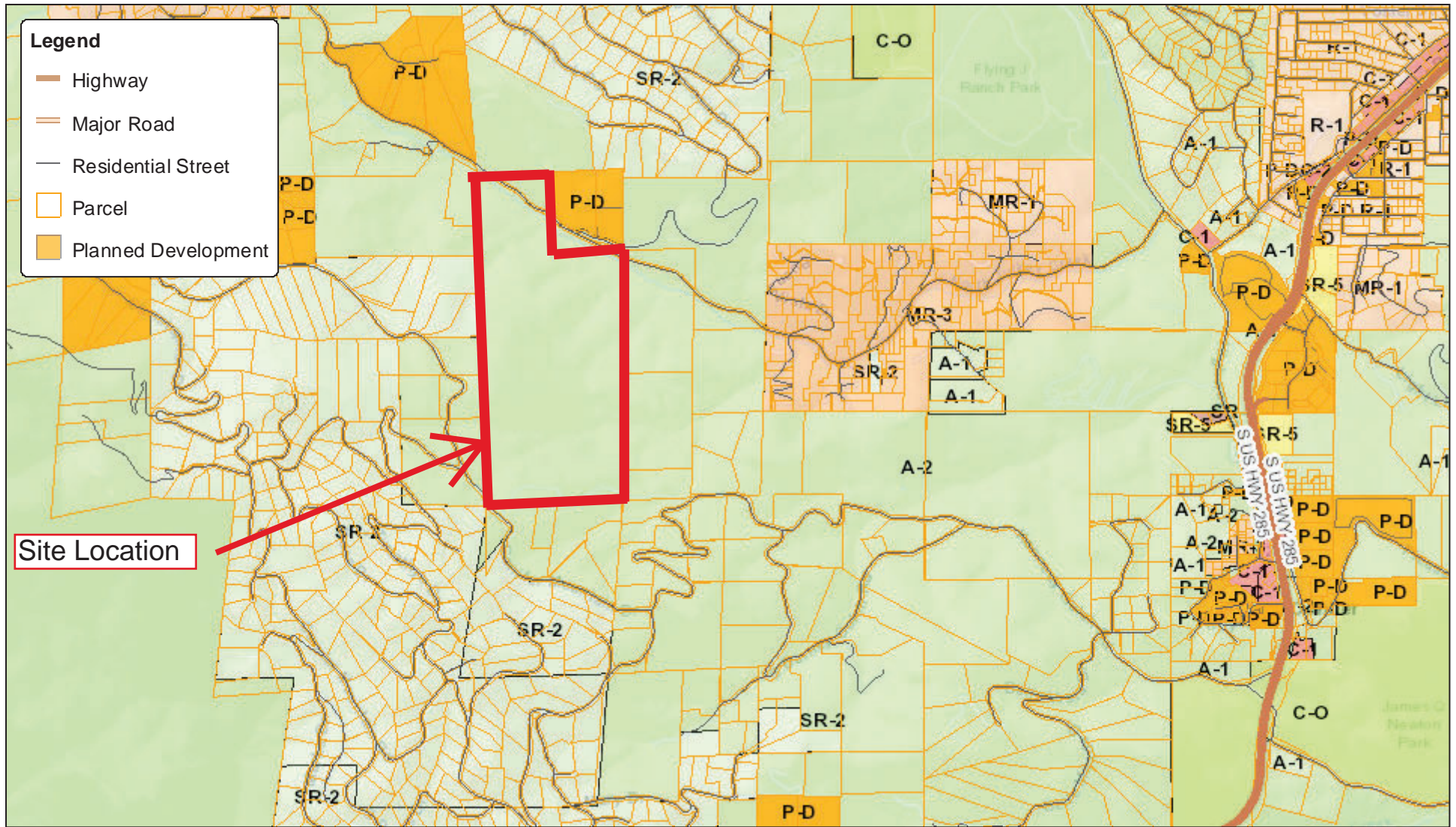

Site Location



Jefferson County offers this service for informational purposes only for the convenience of the user and assumes no liability whatsoever associated with the use or misuse of this data. This data is provided "as is" and Jefferson County disclaims all representations and warranties expressed or implied, including without limitation all representations and warranties as to the completeness, accuracy, correctness, merchantability and fitness for a particular purpose of any data and any and all warranties of title related thereto.

Sources: Esri, HERE, Garmin, USGS, Intermap, INCREMENT P, NRCan, Esri Japan, METI, Esri China (Hong Kong), Esri Korea, Esri (Thailand), NGCC, (c) OpenStreetMap contributors, and the GIS User Community

Author: ArcGIS Web AppBuilder
Date: 11/27/2023





Figure A.3 Zoning Map

470000

471000



Legend

-  Site Limit
-  Noise Receptor
-  Point Source
-  Line Source
-  Daytime Noise Contour 4.5m (15ft.) AG

4375000

4375000

4375000

4375000

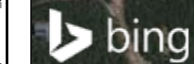

470000

471000

4376000

4375000

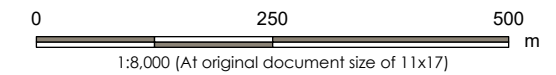

- Notes**
1. Coordinate System: NAD 1983 UTM Zone 13N
 2. Base features produced under creative commons license with the Colorado Department of Transportation © 2022.
 3. Orthoimagery © 2024 Microsoft Corporation © 2024 Maxar © CNES (2024) Distribution Airbus DS

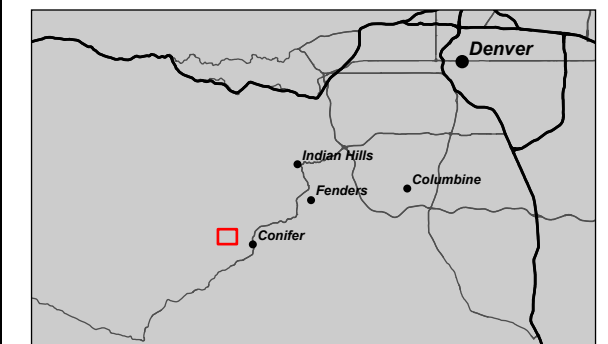

Project Location: Jefferson County, CO
 Prepared by MDA on 2024-03-19
 Technical Review by BCC on 2023-11-30

Client/Project: SE Group
 Shadow Mountain Sensory Impact Study - Noise





Figure No.: **A.4**
 Title: **Daytime Stationary Noise Contour LA₂₅ 4.5m (15 ft. AG)**

470000

471000



Legend

-  Site Limit
-  Noise Receptor
-  Point Source
-  Line Source
-  Nighttime Noise Contour 4.5m (15 ft.) AG

470000

471000

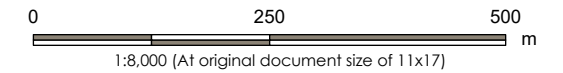
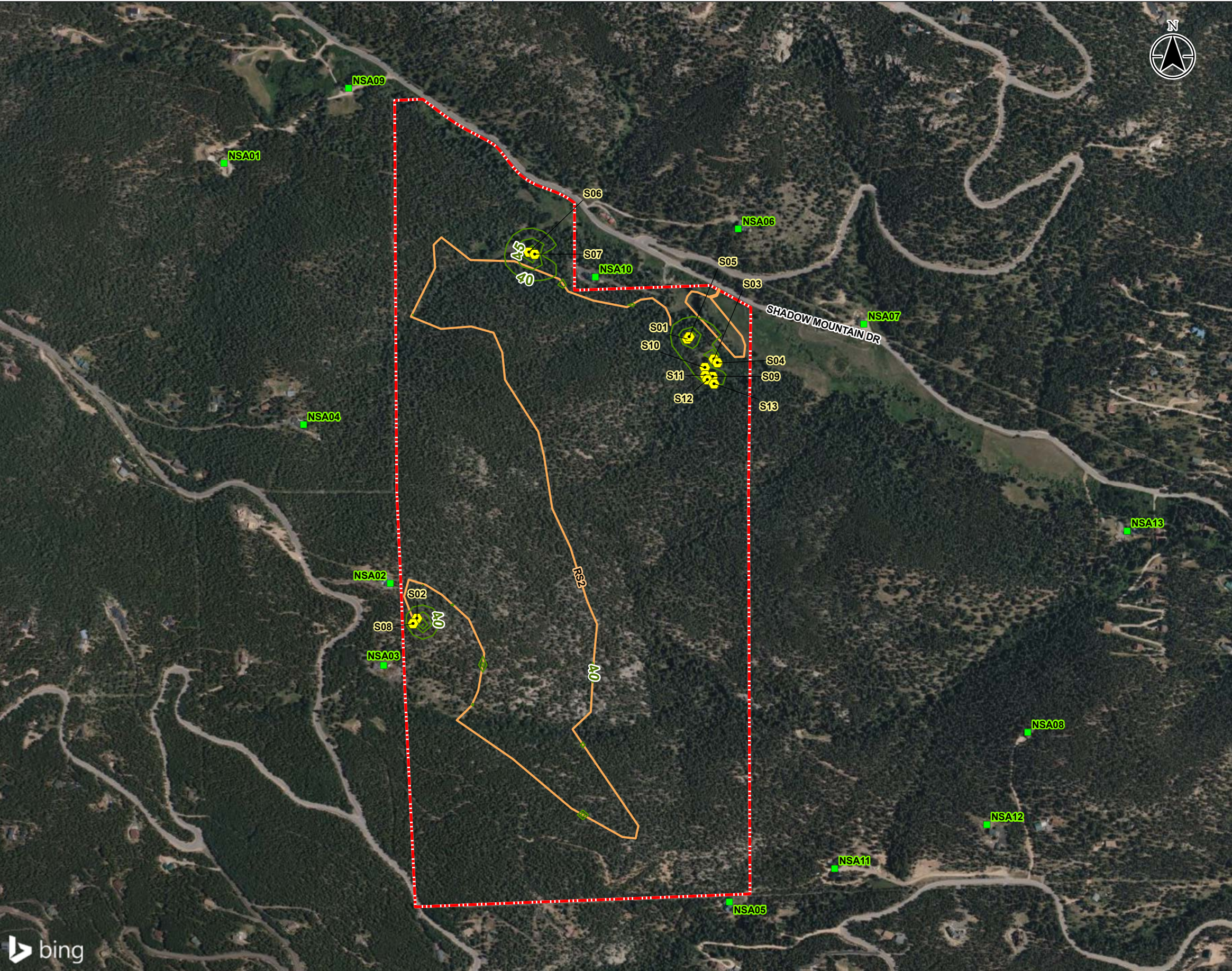

- Notes**
1. Coordinate System: NAD 1983 UTM Zone 13N
 2. Base features produced under creative commons license with the Colorado Department of Transportation © 2022.
 3. Orthoimagery © 2024 Microsoft Corporation © 2024 Maxar © CNES (2024) Distribution Airbus DS

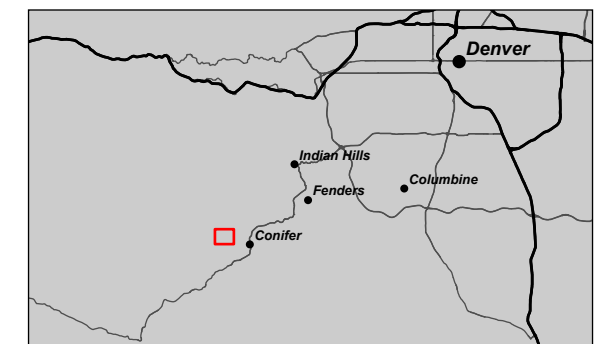

Project Location: Jefferson County, CO
 Prepared by MDA on 2024-03-19
 Technical Review by BCC on 2023-11-30

Client/Project: SE Group
 Shadow Mountain Sensory Impact Study - Noise

Figure No.: **A.5**
 Title: **Nighttime Stationary Noise Contour LA₂₅ 4.5m (15 ft. AG)**







\va0004-ppes\work_group\01609\active_Other_PCo_Active\009_GIS\181711248\03_data\figs\cat\figs\noise\report_figures\noise_181711248_noise_181711248_nighttime
 Revised: 2024-03-19 By: malcazaren
 4375000
 4375000

470000

471000



Legend

-  Site Limit
-  Noise Receptor
-  Point Source
-  Line Source
-  Daytime Noise Contour 4.5m (15ft.) AG

4375000

4375000

4375000

4376000

4375000

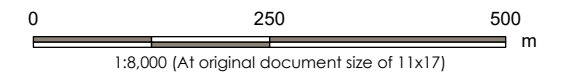

- Notes**
1. Coordinate System: NAD 1983 UTM Zone 13N
 2. Base features produced under creative commons license with the Colorado Department of Transportation © 2022.
 3. Orthoimagery © 2024 Microsoft Corporation © 2024 Maxar © CNES (2024) Distribution Airbus DS

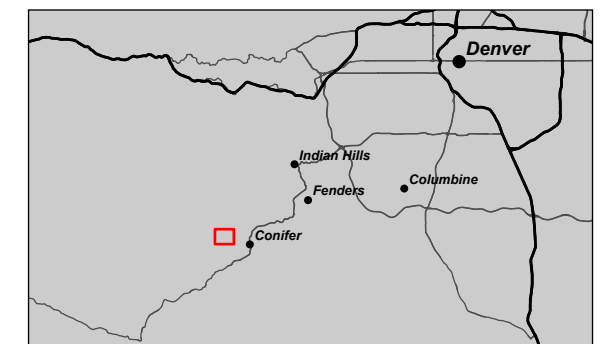

Project Location: Jefferson County, CO
 Prepared by MDA on 2024-03-20
 Technical Review by BCC on 2023-11-30

Client/Project: SE Group
 Shadow Mountain Sensory Impact Study - Noise

Figure No.: **A.6**
 Title: **Daytime Stationary Noise Contour LA₀ 4.5m (15 ft. AG)**

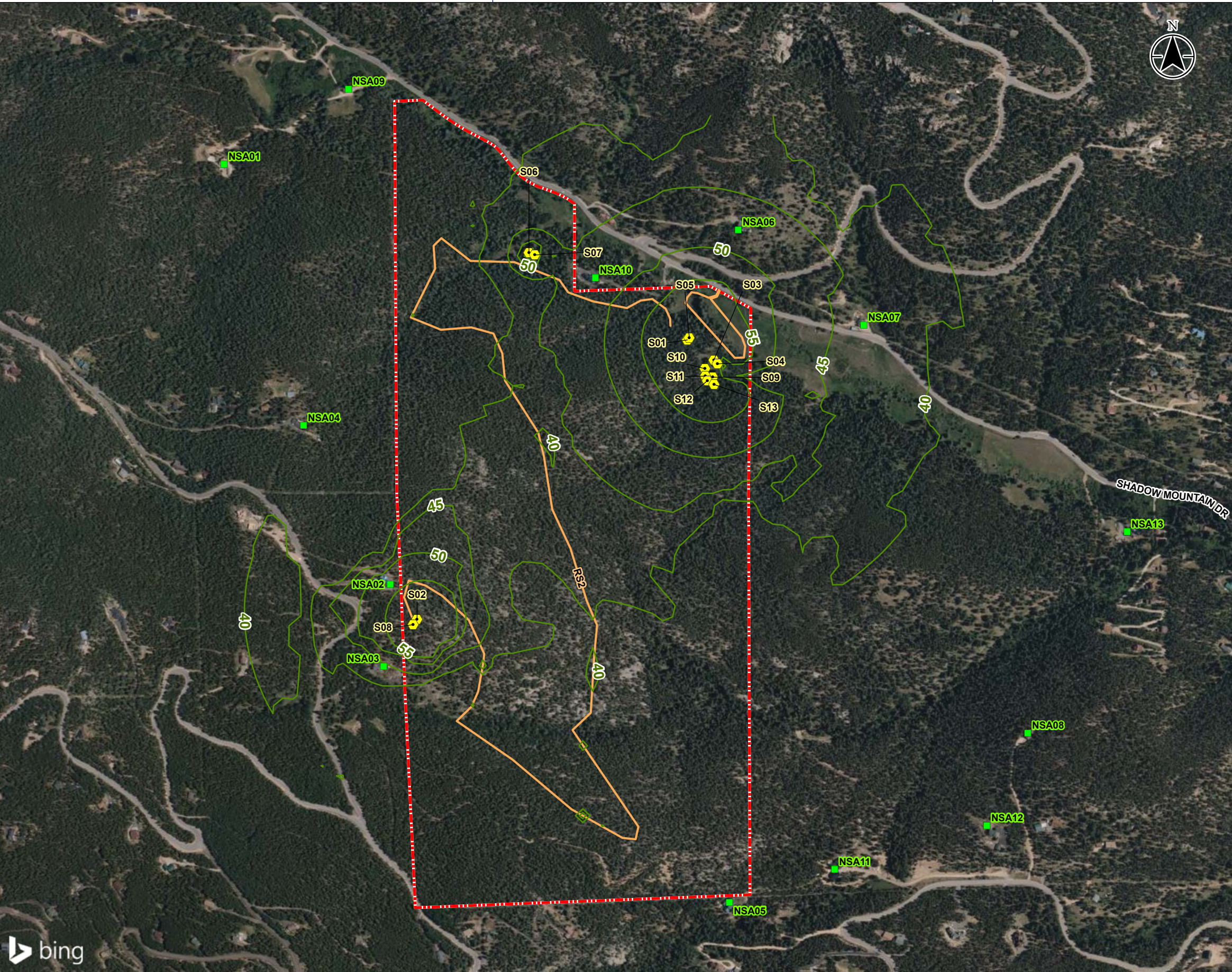

470000





471000

470000

471000



Legend

-  Site Limit
-  Noise Receptor
-  Point Source
-  Nighttime Noise Contour 4.5m (15 ft.) AG
-  Line Source

470000

471000

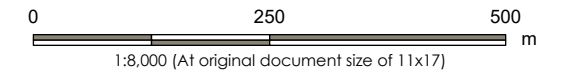
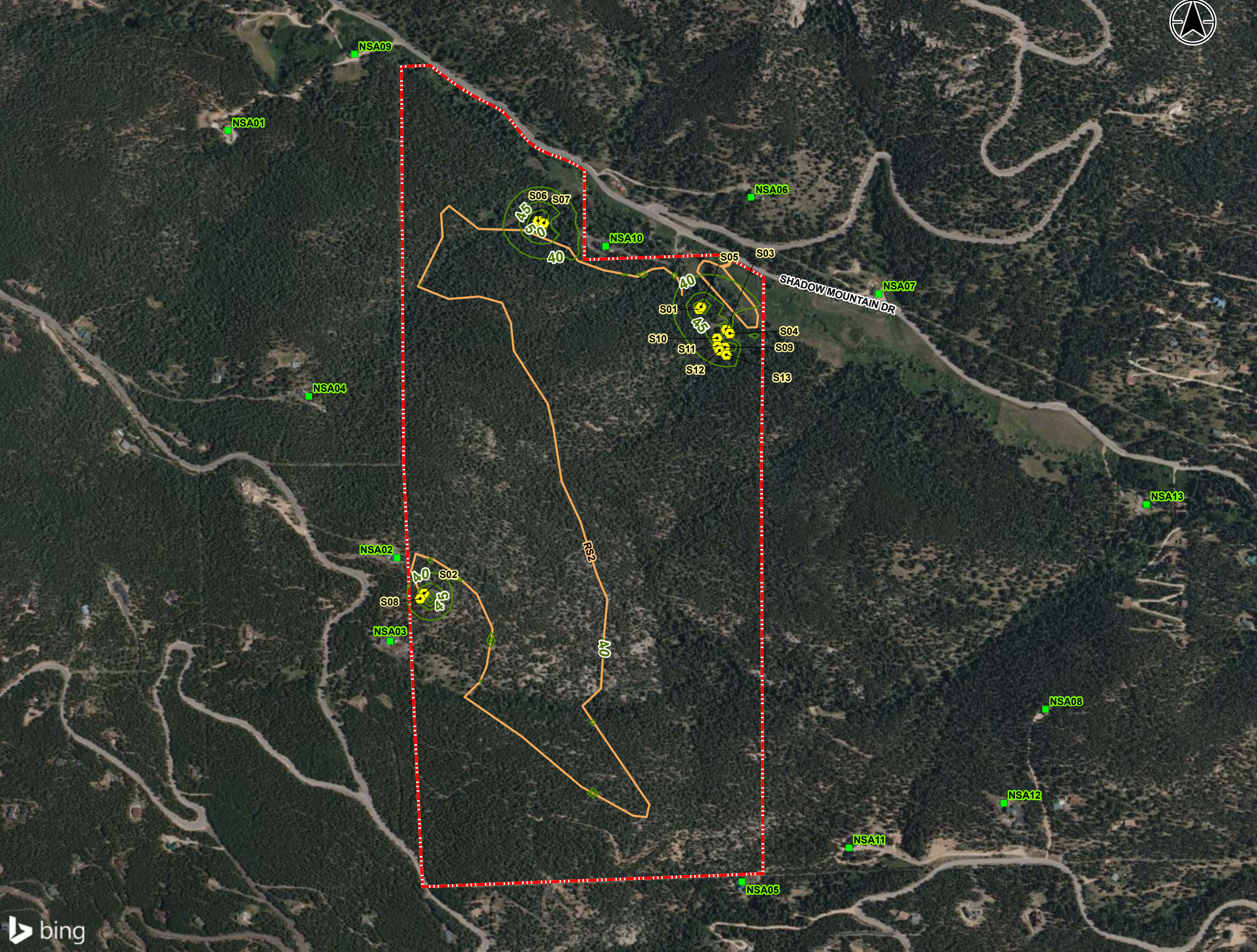

- Notes**
1. Coordinate System: NAD 1983 UTM Zone 13N
 2. Base features produced under creative commons license with the Colorado Department of Transportation © 2022.
 3. Orthoimagery © 2024 Microsoft Corporation © 2024 Maxar © CNES (2024) Distribution Airbus DS

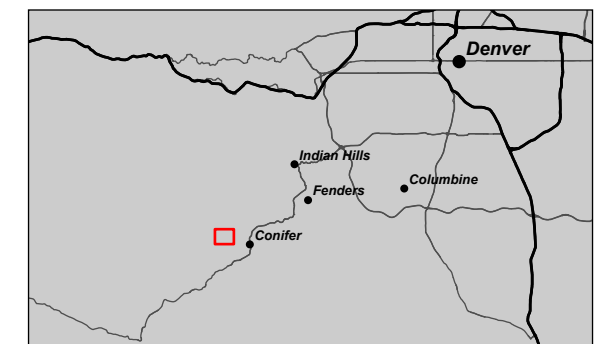

Project Location: Jefferson County, CO
 Prepared by MDA on 2024-03-19
 Technical Review by BCC on 2023-11-30

Client/Project: SE Group
 Shadow Mountain Sensory Impact Study - Noise

Figure No.: **A.7**
 Title: **Nighttime Stationary Noise Contour LA₀ 4.5m (15 ft. AG)**







V:\0004-ppes\04work_group\01609\active_Other_PCo_Active\009_GIS\181711248\03_data\figs\noise\report_figures\noise_181711248_noise_is_spr\181711248_fig07_nightime
 Revised: 2024-03-20 By: malcazaren
 4375000
 4375000

470000

471000



Legend

-  Site Limit
-  Noise Receptor
-  Point Source
-  Line Source
-  Daytime Noise Contour Lmax (dBA)

4375000

4375000

4375000

4375000

4375000

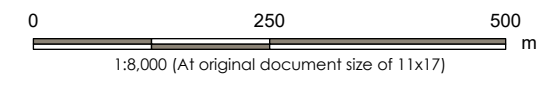
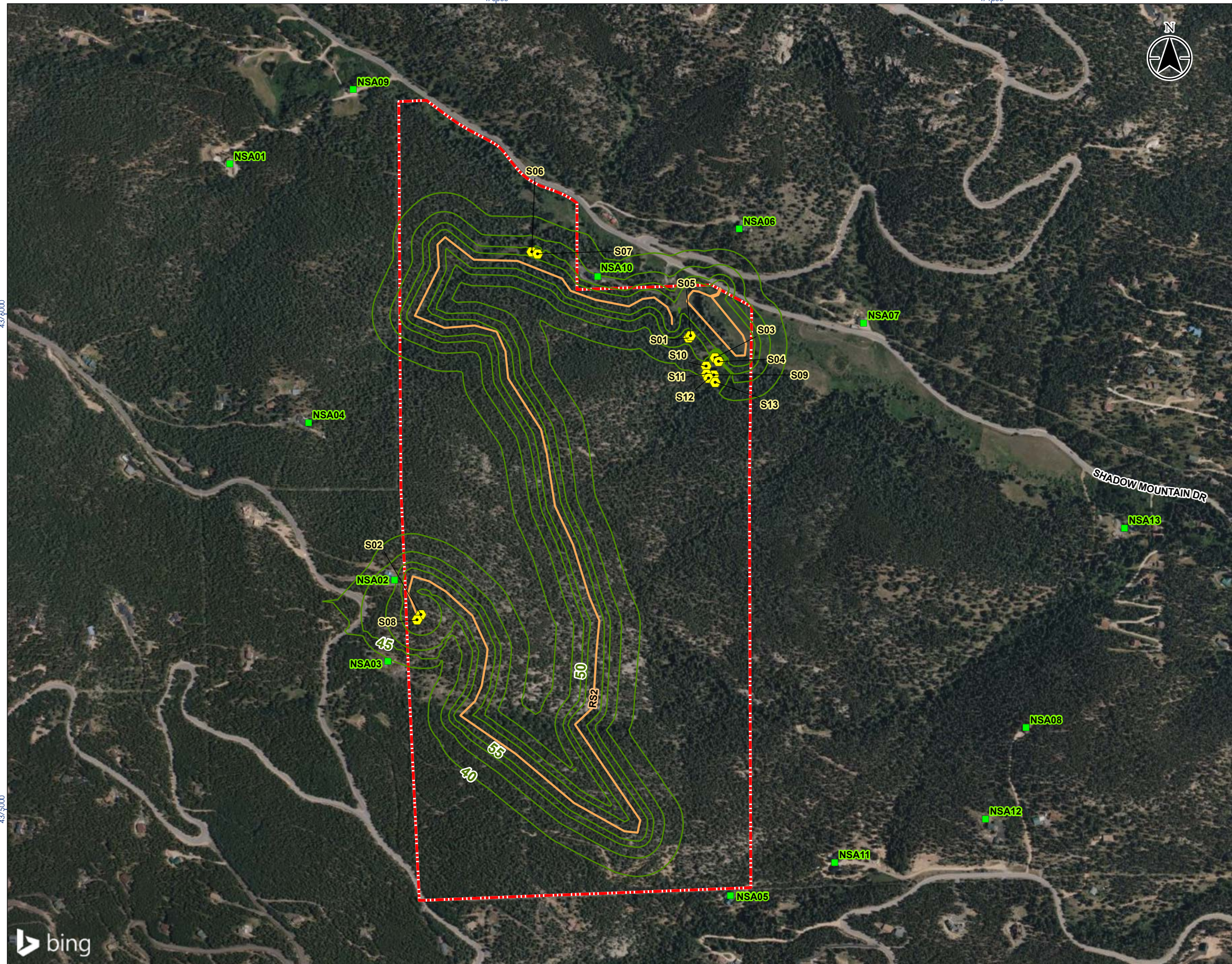

- Notes**
1. Coordinate System: NAD 1983 UTM Zone 13N
 2. Base features produced under creative commons license with the Colorado Department of Transportation © 2022.
 3. Orthoimagery © 2024 Microsoft Corporation © 2024 Maxar © CNES (2024) Distribution Airbus DS

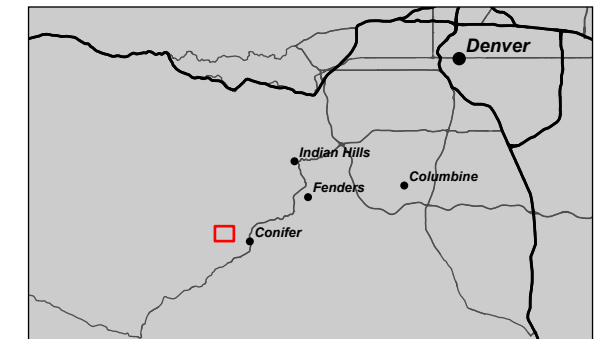

Project Location: Jefferson County, CO
 Prepared by MDA on 2024-03-19
 Technical Review by BCC on 2023-11-30

Client/Project: SE Group
 Shadow Mountain Sensory Impact Study - Noise

Figure No.: **A.8**
 Title: **Daytime Mobile Noise Contour LA₀ 4.5 AG (15 ft. AG)**



470000

471000

Disclaimer: Stantec assumes no responsibility for data supplied in electronic format. The recipient accepts full responsibility for verifying the accuracy and completeness of the data. The recipient releases Stantec, its officers, employees, consultants and agents, from any and all claims arising in any way from the content or provision of the data.



LSC TRANSPORTATION CONSULTANTS, INC.

1889 York Street
Denver, CO 80206
(303) 333-1105
FAX (303) 333-1107
E-mail: lsc@lscdenver.com

April 3, 2024

Mr. Travis Beck
SE Group
tbeck@segrou.com

Re: Shadow Mountain
Bike Park
Jefferson County, CO
LSC #220850

Dear Mr. Beck:

In response to your request, LSC Transportation Consultants, Inc. has prepared this updated traffic impact analysis for the proposed Shadow Mountain Bike Park development to address County comments. As shown on Figure 1, the site is located south of Shadow Mountain Drive about two miles west of County Highway 73 in Jefferson County, Colorado.

REPORT CONTENTS

The report contains the following: the existing roadway and traffic conditions in the vicinity of the site including the lane geometries, traffic controls, posted speed limits, etc.; the existing weekday, Saturday, and Sunday peak-hour traffic volumes; the existing daily traffic volumes in the area; the typical weekday, Saturday, and Sunday site-generated traffic volume projections; the assignment of the projected traffic volumes to the area roadways; the projected long-term background and resulting total traffic volumes on the area roadways; the site's projected traffic impacts; and any recommended roadway improvements to mitigate the site's traffic impacts or the impacts from growth in background traffic.

LAND USE AND ACCESS

The site is proposed to include a downhill mountain bike park with lift service. The site is proposed to have about 300 parking spaces and with about 20 employees. Full movement access is proposed from Shadow Mountain Drive as shown in the conceptual site plan in Figure 2.

The applicant plans to implement ticketing and parking technology to avoid guests arriving with nowhere to park to help reduce impacts to the surrounding area. This process is described as follows:

Parking Reservations

The applicant (SMBP) will implement a parking reservation system that will be available at the time that visitors purchase bike park passes. SMBP will strongly encourage visitors to purchase tickets online prior to arrival, with the goal of making sure visitors do not arrive at the bike

park without a parking reservation. SMBP has decided to implement this system to benefit the visitor experience and surrounding community in the following ways:

1. The parking reservation system will control the amount of riders the bike park sees on any given day, thereby limiting pressure on SMBP's trail network and ensuring the bike park is never over visitor capacity. Limiting visitor capacity will also limit pressure on local roadways, thereby benefitting the surrounding neighborhood as well. The reservation system will allow visitors to relinquish their parking spot when they're done riding so that the parking reservation system stays up-to-date for incoming visitors.
2. The parking reservation system has the ability to reduce the potential for roadway congestion around morning and evening peak-hours because visitors will have a reservation and will have no incentive to rush to SMBP to find parking during opening hours or other peak times.
3. SMBP's parking reservation system will allow staff to closely manage the activity of bike park visitors, which will allow staff to quickly remedy any issues that arise between visitors and residential traffic using the roadways near SMBP.

Cell Phone Service

The base area, in its existing condition, has cell coverage. The rest of the project area has limited coverage. SMBP plans to provide Wifi from the day lodge and work with major providers to improve cell service in the project area for riders.

ROADWAY AND TRAFFIC CONDITIONS

Area Roadways

The major roadways in the site's vicinity are shown on Figure 1 and are described below.

- **County Highway 73** is a north-south, two-lane major collector roadway east of the site. The intersection with Shadow Mountain Drive is stop-sign controlled. The posted speed limit in the vicinity of the site is 40 mph.
- **Shadow Mountain Drive** is an east-west, two-lane collector roadway north of the site. The intersection with County Highway 73 is stop-sign controlled. The posted speed limit in the vicinity of the site is 40 mph but reduces to 30 mph to the east closer to County Highway 73.
- **Barkley Road** is an east-west, two-lane major collector roadway east of the site. The intersection with County Highway 73 is stop-sign controlled. The posted speed limit in the vicinity of the site is 30 mph.

Existing Traffic Conditions

Figure 3a shows the existing lane geometries, traffic controls, and traffic volumes in the site's vicinity on a typical weekday afternoon peak-hour and the daily traffic volumes for five consecutive days. Figures 3b and 3c show the typical peak-hour and daily traffic volumes on a

Saturday and Sunday, respectively. The peak-hour traffic volumes and daily traffic counts are from the attached traffic counts conducted by Counter Measures in August, 2022.

2025 and 2043 Background Traffic

Figure 4a shows the estimated 2025 weekday background traffic which assumes an annual growth rate of one-half percent on Shadow Mountain Drive and one percent on Highway 73 and Barkley Road to maintain a conservative analysis. DRCOG (Denver Regional Council of Governments) shows minimal growth is expected on Shadow Mountain Drive over time. Figure 4b shows the estimated 2025 Saturday background traffic which assumes an annual growth rate of one-half percent on Shadow Mountain Drive and one percent on Highway 73 and Barkley Road to maintain a conservative analysis. Figure 4c shows the estimated 2025 Sunday background traffic which assumes an annual growth rate of one percent. The Sunday daily volumes are based on multiplying the Sunday peak-hour rates by the ratio of Saturday peak-hour trips to Saturday daily trips.

Figure 5a shows the estimated 2043 weekday background traffic; Figure 5b shows the estimated 2043 Saturday background traffic; and Figure 5c shows the estimated 2043 Sunday background traffic. These 2043 background volumes assume an annual growth rate of one percent.

Existing, 2025, and 2043 Background Levels of Service

Level of service (LOS) is a quantitative measure of the level of congestion or delay at an intersection. Level of service is indicated on a scale from “A” to “F.” LOS A is indicative of little congestion or delay and LOS F is indicative of a high level of congestion or delay. Attached are specific level of service definitions for unsignalized intersections.

The intersections in Figures 3a through 5c were analyzed as appropriate to determine the existing, 2025 background, and 2043 background levels of service using Synchro. Table 1a shows the existing and 2025 level of service analysis results and Table 1b shows the 2043 level of service results. The level of service reports are attached.

- 1. Shadow Mountain Drive/County Highway 73:** All movements at this unsignalized intersection currently operate at LOS “D” or better during all five scenarios and are expected to do so through 2025. By 2043, the intersection is planned to be converted to a modern roundabout and is expected to operate at an overall LOS “A” during all scenarios.
- 2. County Highway 73/Barkley Road:** All movements at this unsignalized intersection currently operate at LOS “D” or better during all five scenarios with the following exception: The southwestbound to southeastbound left-turn movement operates at LOS “F” during the weekday afternoon peak-hour and the Saturday mid-day peak-hour. By 2025, the southwestbound left-turn movement is expected to operate at LOS “E” or “F” during the weekday afternoon peak-hour, and the Saturday morning and mid-day peak-hour. By 2043, the intersection is planned to be converted to a modern roundabout and is expected to operate at an overall LOS “A” during all scenarios.
- 3. Shadow Mountain Drive/Site Access:** This unsignalized intersection was analyzed only in the total traffic scenarios.

TRIP GENERATION

Table 2 shows the estimated trip generation for the proposed site per the rates developed by LSC based on coordination with the applicant and project team.

The site is projected to generate about 520 vehicle-trips on the average weekday, with about half entering and half exiting during a 24-hour period. During the morning peak-hour, which generally occurs for one hour between 6:30 and 8:30 a.m., about 115 vehicles would enter and about 11 vehicles would exit the site. During the afternoon peak-hour, which generally occurs for one hour between 4:00 and 6:00 p.m., about 8 vehicles would enter and about 80 vehicles would exit.

On the average Saturday and Sunday, the site is projected to generate up to about 1,000 vehicle-trips with about half entering and half exiting during a 24-hour period. During the morning peak-hour, which generally occurs for one hour between 8:30 and 10:30 a.m., about 220 vehicles would enter and about 21 vehicles would exit the site. During the mid-day peak-hour, which generally occurs for one hour between 12:00 and 2:00 p.m., about 15 vehicles would enter and about 155 vehicles would exit.

The average daily traffic during the peak season is expected to be between 520 and 1,000 trips; most weekdays are expected to have 520 or fewer trips.

Details on Vehicle Turnover

This report assumes a vehicle/parking stall turnover estimate of 1.6 (i.e., a parking stall will have 1.6 vehicles parked each day). This estimate is based on a number of factors, including trail mileage, vertical relief, chairlift length, lap time, number of laps/visit, vehicular travel distance to bike park, ticket type (day pass vs. season pass), and length of stay. Specifically, based on these factors, it is estimated that an average lap would be approximately 30 minutes, the average number of laps would be 8 laps, and the amount of milling time (i.e., parking, ticketing, break time/lunch) would be approximately 1 hour. With this information, the average guest would stay approximately 5 hours. For an average operating time of 8 hours, the average vehicle turnover would be the average operating time divided by the average guest stay. This results in an average turnover of 1.6, meaning that on days with a full parking lot, about 60 percent of the spaces could be vacated and then replaced by another vehicle.

The average vehicle turnover is a planning metric used to inform traffic and parking estimates. In this study, it directly informs the average number of vehicles entering and exiting the parking lot and thus the average vehicle trips per day, however, has a less direct correlation with peak traffic patterns because it applies to the full day of operation. Because of the uniqueness of the operation and the variety of planning factors considered to determine the vehicular turnover, there is not an “industry-standard” planning metric.

Details on Visitation

The traffic study assumes 300 parking spaces with a 1.6 turnover ratio per day for a total of 480 guest vehicles per day. Each vehicle enters and exits the site once for a total of 960 daily trips. An additional 40 trips (20 vehicles) were added for employee trips to arrive at 1,000 daily

trips. A vehicle occupancy of 2.5 people per vehicle in 480 vehicles would result in 1,200 guests. There are also 20 employees for a total of 1,220 unique people per day. Our parking turnover assumptions mean these 1,220 people can't all be on the site at the same time. The most people on the site at any given time would be 300 vehicles x 2.5 people/vehicle for 750 guests plus 20 employees for a total of 770 people.

These assumptions are dependent on the assumed 2.5 vehicle occupancy which could vary slightly from day to day. As described above, the Applicant will implement a reservation system to carefully monitor the number of vehicles and guests visiting the site so as to not exceed stated maximums.

TRIP DISTRIBUTION

Figure 6 shows the estimated directional distribution of the site-generated traffic volumes on the area roadways. The estimates were based on the location of the site with respect to the regional population, employment, and activity centers; and the site's proposed land use.

TRIP ASSIGNMENT

Figure 7a shows the estimated weekday site-generated traffic volumes based on the weekday trip generation estimate (from Table 2) and the directional distribution in Figure 6.

Figure 7b shows the estimated Saturday/Sunday site-generated traffic volumes based on the Saturday/Sunday trip generation estimate (from Table 2) and the directional distribution in Figure 6.

2025 AND 2043 TOTAL TRAFFIC

Figure 8a shows the 2025 weekday total traffic which is the sum of the 2025 weekday background traffic volumes (from Figure 4a) and the weekday site-generated traffic volumes (from Figure 7a). Figure 8a also shows the recommended lane geometry and traffic control.

Figure 8b shows the 2025 Saturday total traffic which is the sum of the 2025 Saturday background traffic volumes (from Figure 4b) and the weekend site-generated traffic volumes (from Figure 7b). Figure 8b also shows the recommended lane geometry and traffic control.

Figure 8c shows the 2025 Sunday total traffic which is the sum of the 2025 Sunday background traffic volumes (from Figure 4c) and the weekend site-generated traffic volumes (from Figure 7b). Figure 8c also shows the recommended lane geometry and traffic control.

Figure 9a shows the 2043 weekday total traffic which is the sum of the 2043 weekday background traffic volumes (from Figure 5a) and the weekday site-generated traffic volumes (from Figure 7a). Figure 9a also shows the recommended lane geometry and traffic control.

Figure 9b shows the 2043 Saturday total traffic which is the sum of the 2043 Saturday background traffic volumes (from Figure 5b) and the weekend site-generated traffic volumes (from Figure 7b). Figure 9b also shows the recommended lane geometry and traffic control.

Figure 9c shows the 2043 Sunday total traffic which is the sum of the 2043 Sunday background traffic volumes (from Figure 5c) and the weekend site-generated traffic volumes (from Figure 7b). Figure 9c also shows the recommended lane geometry and traffic control.

PROJECTED LEVELS OF SERVICE

The intersections in Figures 8a through 9c were analyzed to determine the 2025 and 2043 total traffic levels of service. Table 1a shows the existing and 2025 total level of service analysis results and Table 1b shows the 2043 total level of service results. The level of service reports are attached.

- 1. Shadow Mountain Drive/County Highway 73:** All movements at this unsignalized intersection are expected to operate at LOS “D” or better during all five scenarios through 2043 with the following exception: The northeastbound left-turn movement is expected to operate at LOS “E” or “F” during three of the five scenarios by 2025. By 2043, the intersection is planned to be converted to a modern roundabout by Jefferson County and is expected to operate at an overall LOS “B” or better during all scenarios.
- 2. County Highway 73/Barkley Road:** All movements at this unsignalized intersection are expected to operate at LOS “D” or better during all five scenarios through 2043 with the following exception: The southwestbound left-turn movement is expected to operate at LOS “E” or “F” during four of the five scenarios in 2025 and 2043. By 2043, the intersection is planned to be converted to a modern roundabout by Jefferson County and is expected to operate at an overall LOS “C” or better during all scenarios.
- 3. Shadow Mountain Drive/Site Access:** All movements at this unsignalized intersection are expected to operate at LOS “A” during all five scenarios through 2043.

CONCLUSIONS AND RECOMMENDATIONS

Trip Generation

1. The site is projected to generate about 520 vehicle-trips on the average weekday, with about half entering and half exiting during a 24-hour period. During the morning peak-hour, about 115 vehicles would enter and about 11 vehicles would exit the site. During the afternoon peak-hour, about 8 vehicles would enter and about 80 vehicles would exit.
2. On the average Saturday and Sunday, the site is projected to generate up to about 1,000 vehicle-trips with about half entering and half exiting during a 24-hour period. During the morning peak-hour, about 220 vehicles would enter and about 21 vehicles would exit the site. During the mid-day peak-hour, about 15 vehicles would enter and about 155 vehicles would exit

Projected Levels of Service

3. All movements at the unsignalized intersections analyzed are expected to operate at LOS “D” or better through 2043 in all five scenarios with the following exceptions: The north-eastbound left-turn movement at the Shadow Mountain Drive/County Highway 73 and the southwestbound left-turn movement at the County Highway 73/Barkley Road inter-

section are expected to operate at LOS “E” or “F” during several of the five scenarios. By 2043, both intersections are planned to be converted to modern roundabouts and are expected to operate at an overall LOS “C” or better during all scenarios. It is important to note that minimal site traffic is expected to make the movements with poor levels of service.

Recommendations

- 4. The recommended improvements to mitigate poor levels of service are shown in Figure 10. These future roundabouts are planned by Jefferson County; the Applicant would work with the County to agree upon a contribution for these improvements. Figure 10 shows the peak season site-generated trips will comprise about 15 percent of Saturday peak-hour trips at the northern roundabout and about 12 percent at the southern roundabout. These percentages will be lower on weekdays and during the off-season.
- 5. The recommended improvements at the site access intersection are per feedback from Jefferson County and are shown in Figures 8a through 8c and 9a through 9c. The west-bound left-turn lane is a requirement per the County’s feedback. The potential acceleration lane will provide minimal benefit so should be discussed further with County staff as the project moves forward.

* * * * *

We trust our findings will assist you in gaining approval of the proposed Shadow Mountain Bike Park development. Please contact me if you have any questions or need further assistance.

Sincerely,

LSC TRANSPORTATION CONSULTANTS, INC.

By  _____
 Christopher S. McGranahan, PE
 Principal/Professional Engineer



CSM/wc 4-3-24

- Enclosures: Tables 1a through 2
 Figures 1 - 10
 Traffic Count Reports
 Level of Service Definitions
 Level of Service Reports

**Table 1a
Intersection Levels of Service Analysis - Existing and 2025
Shadow Mountain Bike Park
Jefferson County, CO
LSC #220850; April, 2024**

Intersection No. & Location	Traffic Control	Existing Traffic					2025 Background					2025 Total - Scenario 1 ⁽¹⁾⁽²⁾					2025 Total - Scenario 2 ⁽¹⁾⁽²⁾				
		Weekday	Saturday		Sunday		Weekday	Saturday		Sunday		Weekday	Saturday		Sunday		Weekday	Saturday		Sunday	
		Level of Service PM	Level of Service AM	Level of Service Mid-Day	Level of Service AM	Level of Service Mid-Day	Level of Service PM	Level of Service AM	Level of Service Mid-Day	Level of Service AM	Level of Service Mid-Day	Level of Service PM	Level of Service AM	Level of Service Mid-Day	Level of Service AM	Level of Service Mid-Day	Level of Service PM	Level of Service AM	Level of Service Mid-Day	Level of Service AM	Level of Service Mid-Day
1) <u>Shadow Mountain Drive/County Highway 73</u>	TWSC																				
NEB Left		D	C	D	B	C	D	C	D	B	C	F	E	E	D	D	F	E	E	D	D
NEB Right		B	B	B	B	B	B	B	B	B	B	B	B	C	B	B	B	B	C	B	B
NWB Left		A	A	A	A	A	A	A	A	A	A	B	A	A	A	A	B	A	A	A	A
Critical Movement Delay		30.4	17.2	30.7	14.7	22.6	31.7	17.5	32.4	14.9	23.5	50.6	36.8	39.0	30.4	26.8	50.6	36.8	39.0	30.4	26.8
2) <u>County Highway 73/Barkley Road</u>	TWSC																				
SEB Left		A	A	B	A	A	A	A	B	A	A	A	A	B	A	A	A	A	B	A	A
SWB Left		F	D	F	C	D	F	E	F	C	D	F	E	F	C	E	F	E	F	C	E
SWB Right		B	B	B	B	B	B	B	B	B	B	C	B	B	B	B	C	B	B	B	B
Critical Movement Delay		74.3	33.8	186.0	18.2	25.9	86.1	37.6	233.5	18.8	27.4	102.8	48.1	>240	20.8	49.8	102.8	48.1	>240	20.8	49.8
3) <u>Shadow Mountain Drive/Site Access</u>	TWSC																				
NB Approach		--	--	--	--	--	--	--	--	--	--	A	A	A	A	A	A	A	A	A	A
WB Left		--	--	--	--	--	--	--	--	--	--	A	A	A	A	A	A	A	A	A	A
Critical Movement Delay		--	--	--	--	--	--	--	--	--	--	8.7	8.9	9.8	8.9	9.7	7.6	7.9	7.5	7.9	7.5

(1) Scenario 1 assumes the construction of a WB left-turn lane on Shadow Mountain Road approaching the site access. Scenario 2 assumes the construction of a WB left-turn lane on Shadow Mountain Road approaching the site access and a right-turn acceleration lane on Shadow Mountain Road departing the site access.

(2) Intersection #3: The critical movement delay is for the NB approach in Scenario 1 and for the WB left in Scenario 2.

Table 1b
Intersection Levels of Service Analysis
Shadow Mountain Bike Park- 2043
Jefferson County, CO
LSC #220850; April, 2024

Intersection No. & Location	Traffic Control	2043 Background					2043 Total - Scenario 1 ⁽¹⁾⁽²⁾					2043 Total - Scenario 2 ⁽¹⁾⁽²⁾				
		Weekday	Saturday		Sunday		Weekday	Saturday		Sunday		Weekday	Saturday		Sunday	
		Level of Service PM	Level of Service AM	Level of Service Mid-Day	Level of Service AM	Level of Service Mid-Day	Level of Service PM	Level of Service AM	Level of Service Mid-Day	Level of Service AM	Level of Service Mid-Day	Level of Service PM	Level of Service AM	Level of Service Mid-Day	Level of Service AM	Level of Service Mid-Day
1) <u>Shadow Mountain Drive/County Highway 73</u>	Roundabout	B	A	B	A	A	B	A	B	A	A	B	A	B	A	A
SEB Approach		A	A	A	A	A	A	A	A	A	A	A	A	A	A	A
NWB Approach		A	A	A	A	A	A	A	B	A	A	A	A	B	A	A
NEB Approach		9.1	6.1	9.1	5.4	7.4	11.3	8.4	10.4	7.4	8.1	11.3	8.4	10.4	7.4	8.1
Entire Intersection Delay		A	A	A	A	A	B	A	B	A	A	B	A	B	A	A
Entire Intersection LOS																
2) <u>County Highway 73/Barkley Road</u>	Roundabout	B	A	B	A	A	B	A	C	A	A	B	A	C	A	A
SEB Approach		A	A	C	A	A	A	A	D	A	B	A	A	D	A	B
NWB Approach		B	A	A	A	A	B	B	A	A	A	B	B	A	A	A
SWB Approach		10.4	7.8	13.5	5.9	8.0	11.6	9.9	20.0	7.0	9.6	11.6	9.9	20.0	7.0	9.6
Entire Intersection Delay		B	A	B	A	A	B	A	C	A	A	B	A	C	A	A
Entire Intersection LOS																
3) <u>Shadow Mountain Drive/Site Access</u>	TWSC	--	--	--	--	--	A	A	A	A	A	A	A	A	A	A
NB Approach		--	--	--	--	--	A	A	A	A	A	A	A	A	A	A
WB Left		--	--	--	--	--	8.8	8.9	9.9	8.9	9.8	7.6	7.9	7.5	7.9	7.5
Critical Movement Delay																

(1) Scenario 1 assumes the construction of a WB left-turn lane on Shadow Mountain Road approaching the site access. Scenario 2 assumes the construction of a WB left-turn lane on Shadow Mountain Road approaching the site access and a right-turn acceleration lane on Shadow Mountain Road departing the site access.

(2) Intersection #3: The critical movement delay is for the NB approach in Scenario 1 and for the WB left in Scenario 2.

Table 2
ESTIMATED TRAFFIC GENERATION
Shadow Mountain Bike Park
Jefferson County, CO
LSC #220850; April, 2024

Trip Generating Category	Vehicle-Trips Generated									
	Weekday					Saturday & Sunday				
	Daily ⁽¹⁾	AM Peak-Hour ⁽²⁾		PM Peak-Hour ⁽²⁾		Daily ⁽¹⁾	AM Peak-Hour ⁽²⁾		PM Peak-Hour ⁽²⁾	
		In	Out	In	Out		In	Out	In	Out
Guests	480	105	11	8	75	960	210	21	15	150
Employees	40	10	0	0	5	40	10	0	0	5
Total ⁽³⁾ =	520	115	11	8	80	1,000	220	21	15	155

Notes:

- (1) Assumes 300 parking spaces and a 1.6 turn over ratio for a total of 480 round-trips on the weekend with half that usage on a typical weekday. Assumes 20 employees with 20 round-trips. A vehicle occupancy of 2.5 would result in 1,200 guests on a capacity day.
- (2) Assumes 70 percent of arrival trips occur during the weekday afternoon peak-hour or Saturday/Sunday morning peak-hour with ten percent being dropped off and 50 percent of departure trips occur during the weekend midday peak-hour with ten percent being dropped off. Assumes half of the employees arrive during the peak-hour and a quarter depart during the peak-hour.
- (3) The average daily traffic for the site during the peak season is expected to be between 520 and 1,000 trips considering most weekdays are expected to have 520 or fewer trips per day.

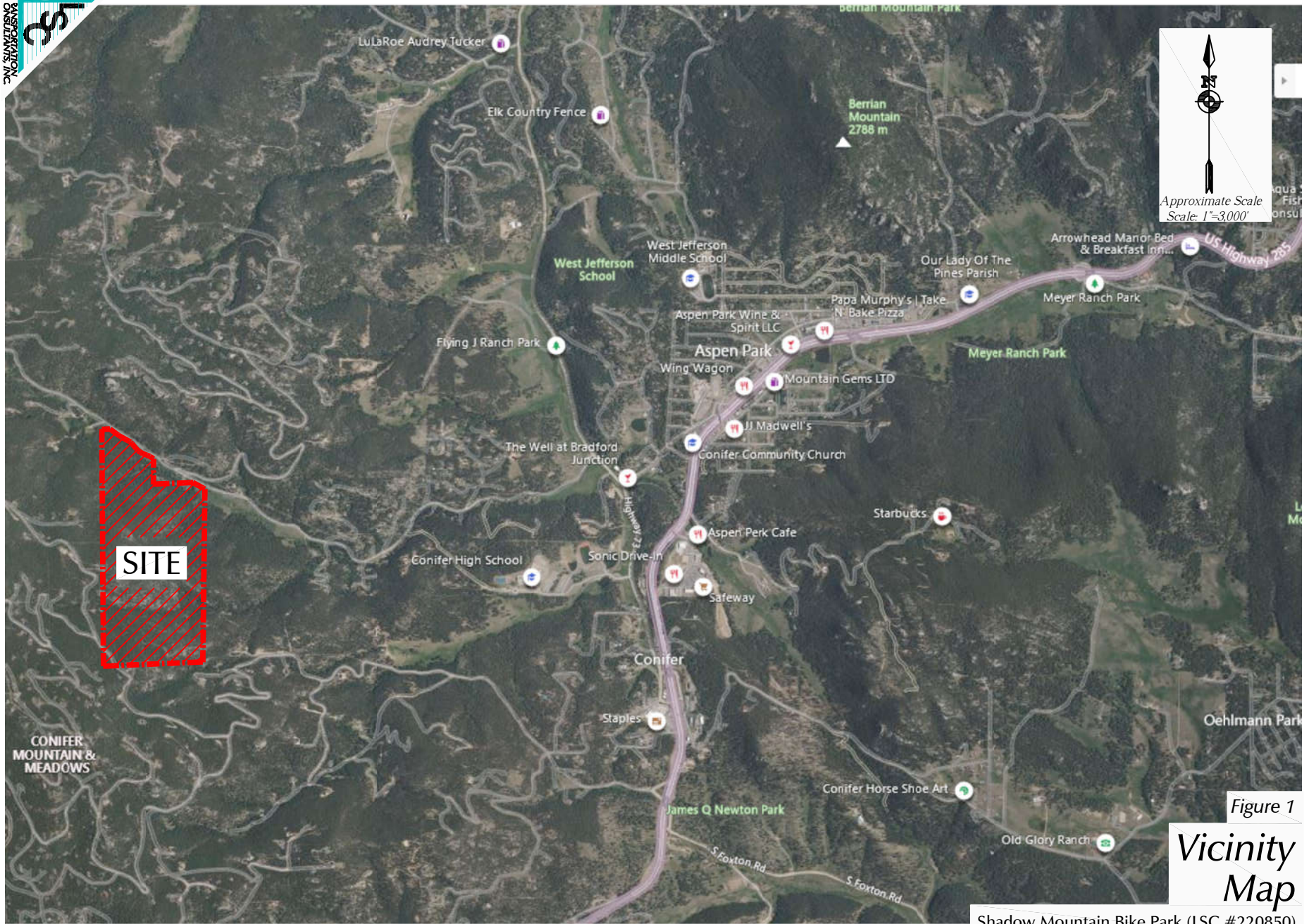

Approximate Scale
Scale: 1"=3,000'

Figure 1

Vicinity Map

Shadow Mountain Bike Park (LSC #220850)

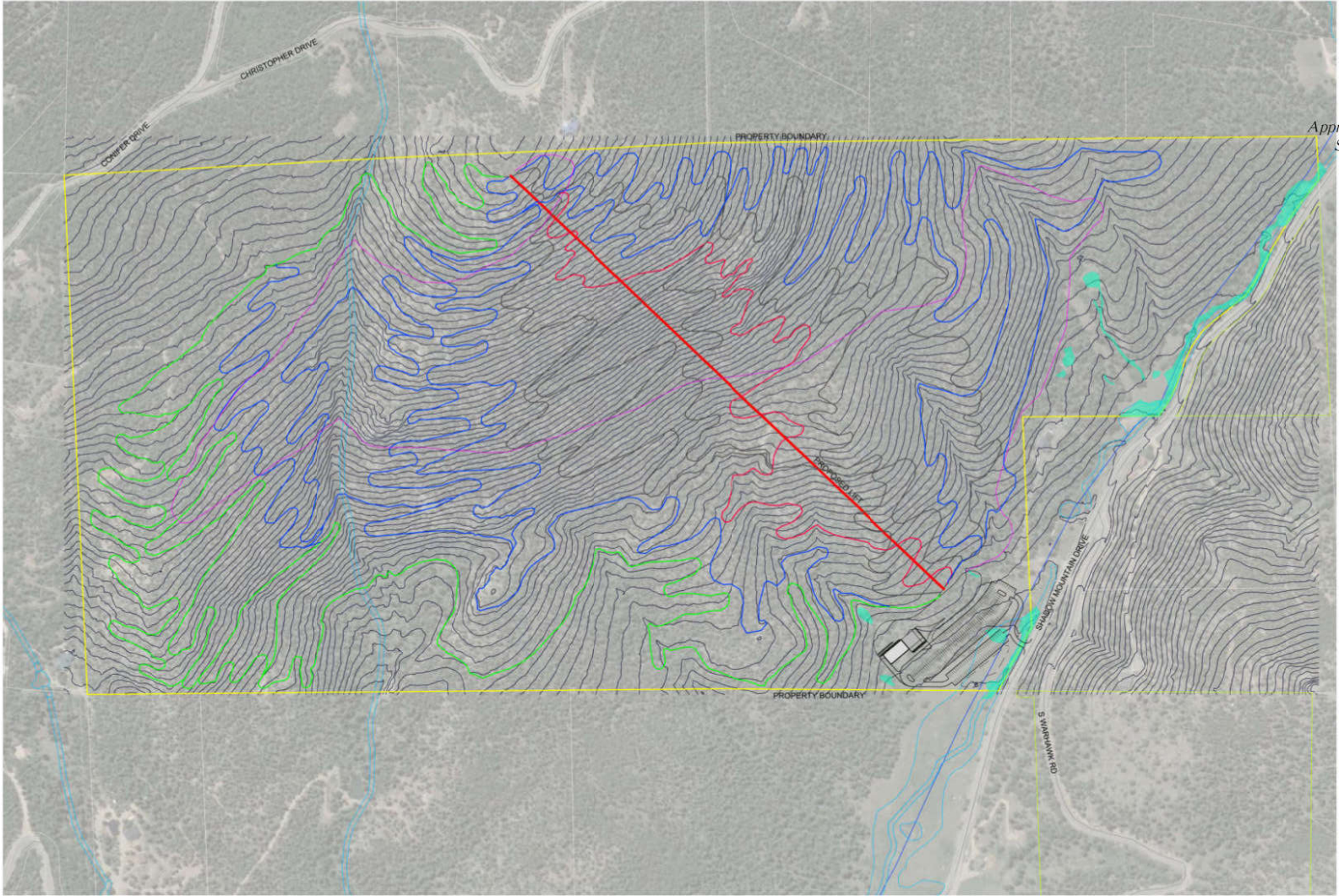
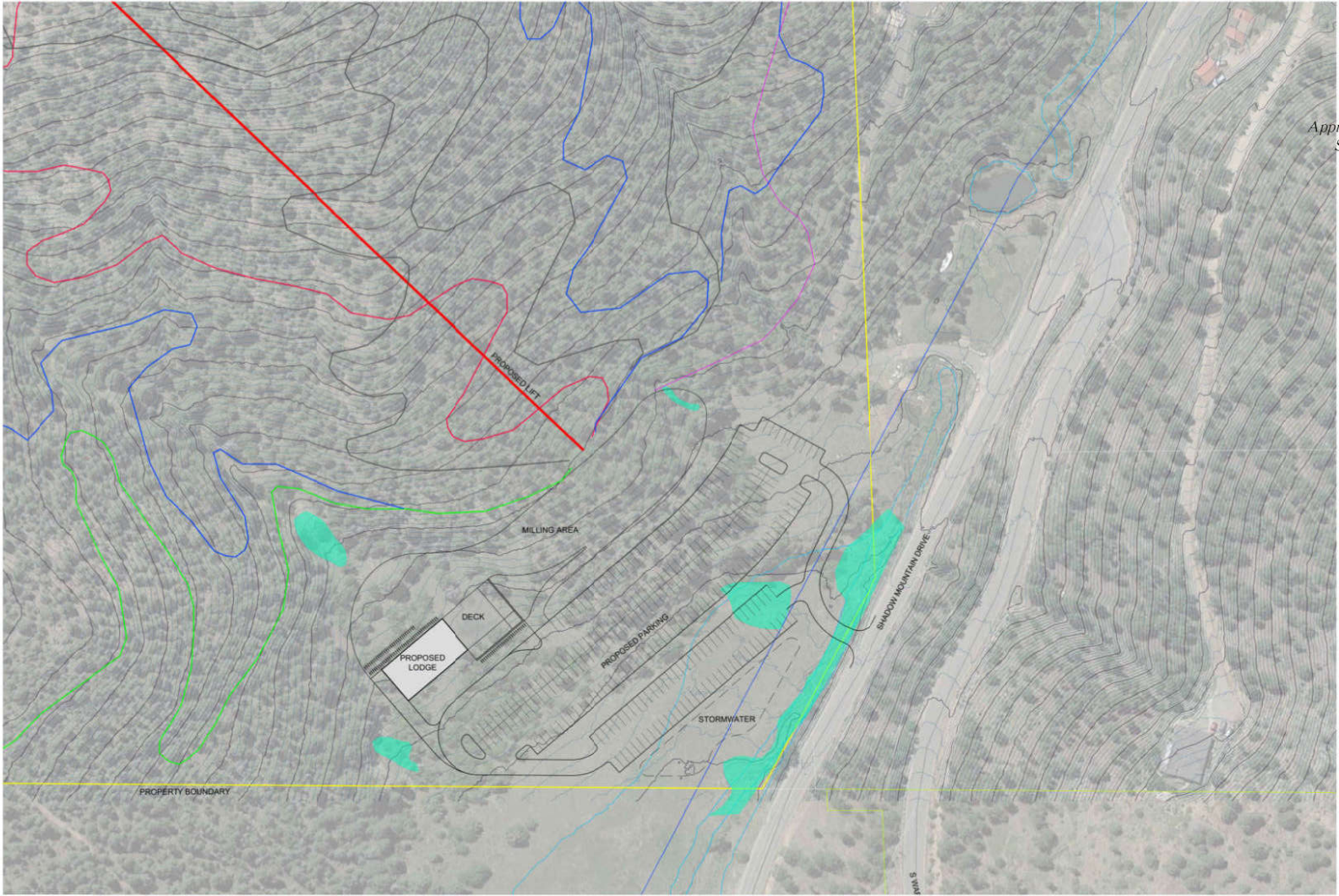

Figure 2a

Note: This site plan is conceptual in size, layout and location. It is subject to change through subsequent review processes.

Overall Site Plan

Shadow Mountain Bike Park (LSC #220850)



North Arrow
Approximate Scale
Scale: NTS

Figure 2b

Note: This site plan is conceptual in size, layout and location. It is subject to change through subsequent review processes.



Parking Lot & Access Detail

Shadow Mountain Bike Park (LSC #220850)



Approximate Scale
Scale: 1"=1,200'

LEGEND:

-  = Stop Sign
-  = Weekday Afternoon Peak Hour Traffic (4:45–5:45pm)
-  = Posted Speed Limit

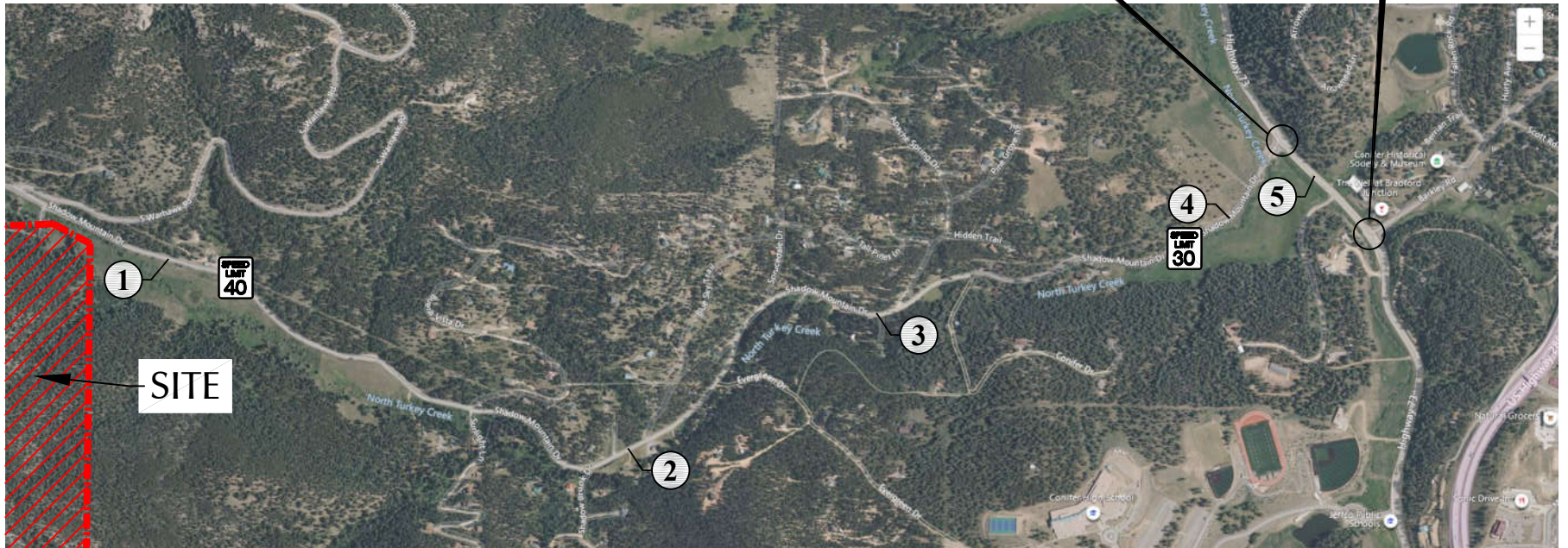
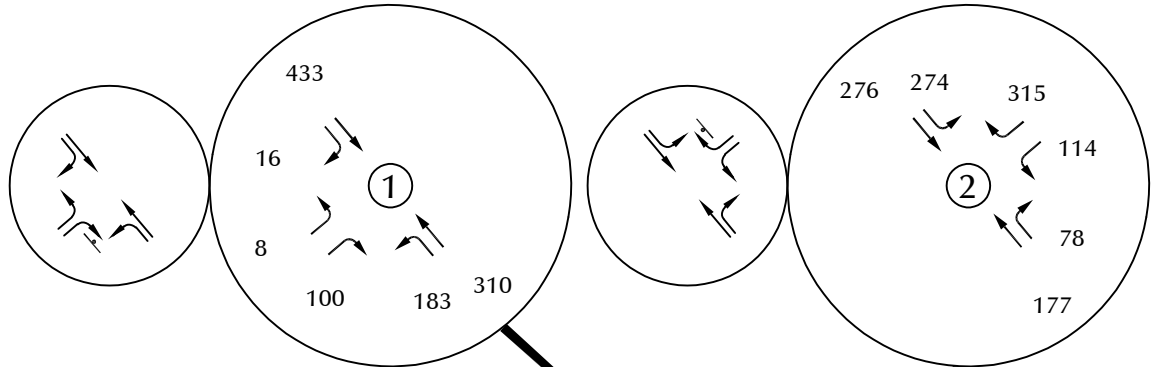

1 Tues 8/23/2022 = 2,455 Wed 8/24/2022 = 2,525 Thur 8/25/2022 = 2,405 Fri 8/26/2022 = 2,365	2 Tues 8/23/2022 = 2,680 Wed 8/24/2022 = 2,750 Thur 8/25/2022 = 2,655 Fri 8/26/2022 = 2,625	3 Tues 8/23/2022 = 3,170 Wed 8/24/2022 = 3,220 Thur 8/25/2022 = 3,120 Fri 8/26/2022 = 3,125	4 Tues 8/23/2022 = No Data Wed 8/24/2022 = No Data Thur 8/25/2022 = 3,155 Fri 8/26/2022 = 3,160	5 Tues 8/23/2022 = 11,390 Wed 8/24/2022 = 11,380 Thur 8/25/2022 = 11,205 Fri 8/26/2022 = 11,470
---	---	---	---	---

Figure 3a

Existing Weekday Peak Hour & All Daily Traffic

Shadow Mountain Bike Park (LSC #220850)



Approximate Scale
Scale: 1"=1,200'

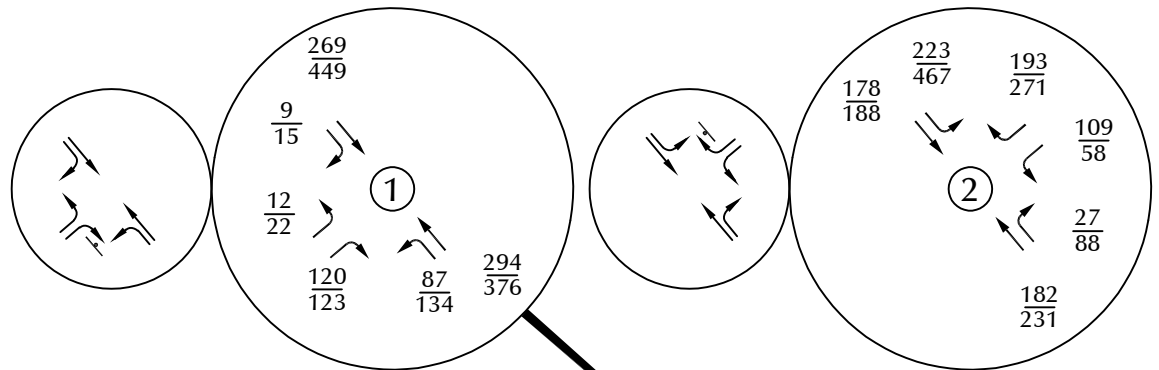

LEGEND:



-  = Stop Sign
- $\frac{26}{35}$ = Saturday Morning Peak Hour Traffic (9:00am–10:00am)
- $\frac{35}{35}$ = Saturday Midday Peak Hour Traffic (12:00pm–1:00pm)
- $\frac{30}{30}$ = Saturday Peak Hour Traffic
-  = Posted Speed Limit

Figure 3b

Existing Saturday Peak Hour Traffic

Shadow Mountain Bike Park (LSC #220850)



Approximate Scale
Scale: 1"=1,200'

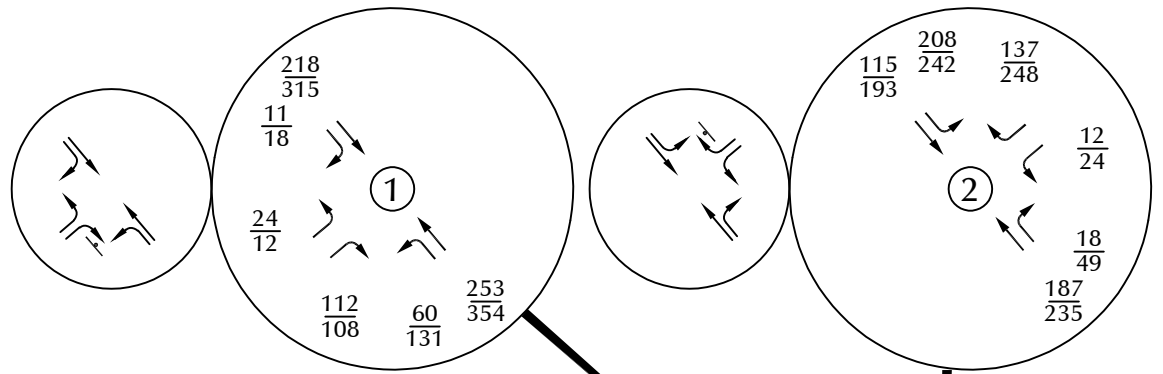

LEGEND:

- ⊥ = Stop Sign
- $\frac{26}{35}$ = Sunday Morning Peak Hour Traffic (9:00am–10:00am)
- $\frac{35}{26}$ = Sunday Middy Peak Hour Traffic (12:30pm–1:30pm)
- = Posted Speed Limit

Figure 3c
Existing
Sunday Peak Hour Traffic
Shadow Mountain Bike Park (LSC #220850)

Approximate Scale
Scale: 1"=1,200'

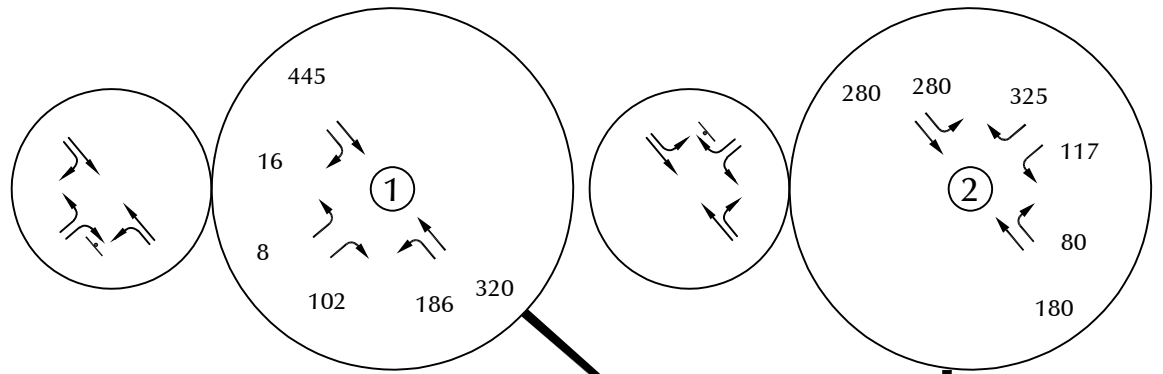
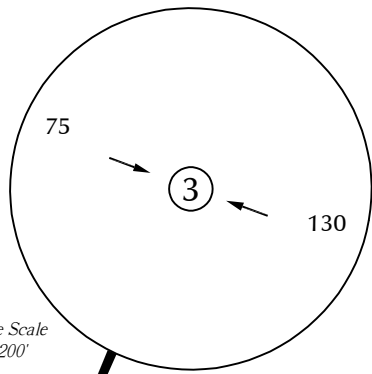

LEGEND:

- ⊥ = Stop Sign
 - 30 = Weekday Afternoon Peak Hour Traffic (4:45–5:45pm)
- Note: Assumes annual growth rate of one half percent on Shadow Mountain Drive and one percent on Highway 73 and Barkley Road to maintain a conservative analysis because DRCOG model predicts little or no growth on Shadow Mountain Drive.

DRCOG = Denver Regional Council of Governments

Figure 4a
Year 2025
Weekday Background Traffic
Shadow Mountain Bike Park (LSC #220850)

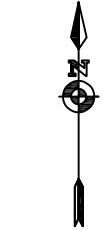

Approximate Scale
Scale: 1"=1,200'

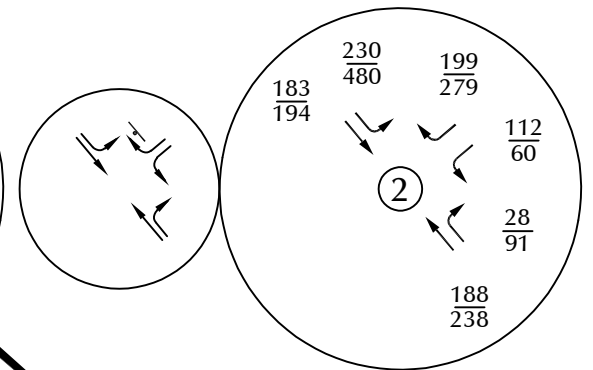
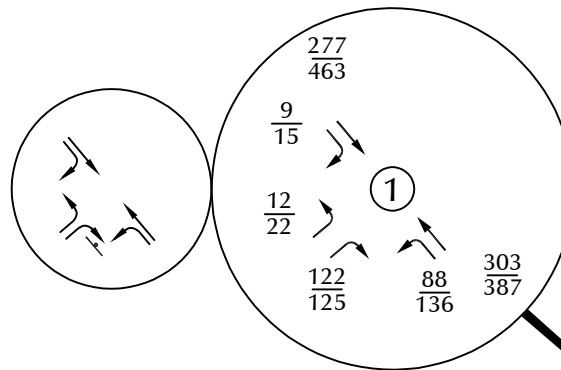
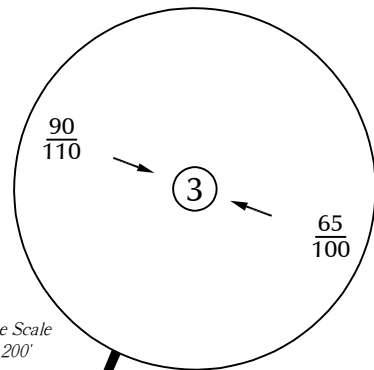

LEGEND:

- ⊥ = Stop Sign
- $\frac{26}{35}$ = Saturday Morning Peak Hour Traffic (9:00am–10:00am)
- $\frac{35}{26}$ = Saturday Midday Peak Hour Traffic (12:00pm–1:00pm)

Note: Assumes annual growth rate of one half percent on Shadow Mountain Drive and one percent on Highway 73 and Barkley Road to maintain a conservative analysis because DRCOG model predicts little or no growth on Shadow Mountain Drive.

DRCOG = Denver Regional Council of Governments

Figure 4b

Year 2025 Saturday Background Traffic

Shadow Mountain Bike Park (LSC #220850)

Approximate Scale
Scale: 1"=1,200'

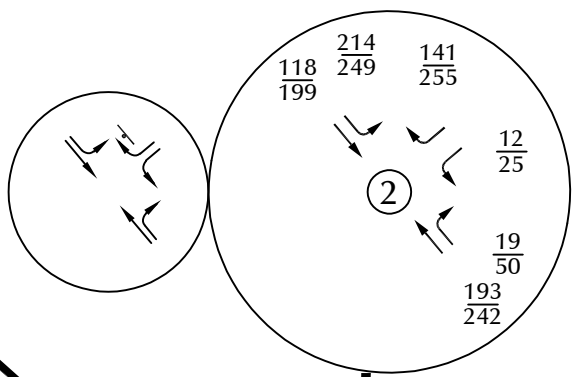
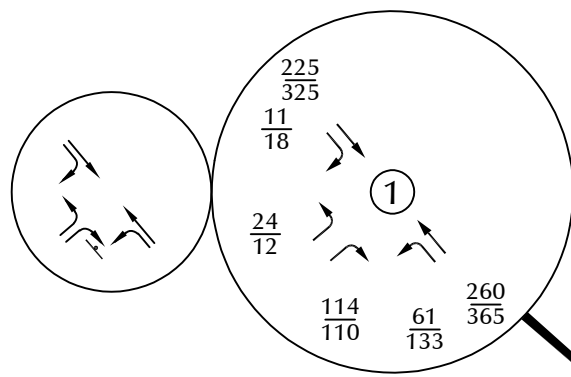
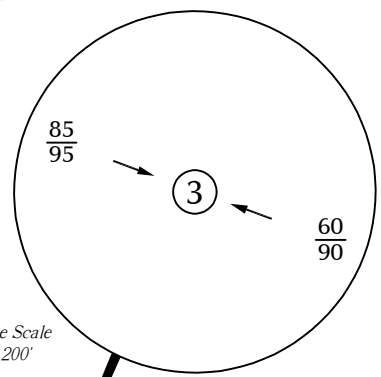

LEGEND:

- ⊥ = Stop Sign
- $\frac{26}{35}$ = Saturday Morning Peak Hour Traffic (9:00am–10:00am)
- $\frac{35}{26}$ = Saturday Midday Peak Hour Traffic (12:00pm–1:00pm)

Note: Assumes annual growth rate of one half percent on Shadow Mountain Drive and one percent on Highway 73 and Barkley Road to maintain a conservative analysis because DRCOG model predicts little or no growth on Shadow Mountain Drive. Daily volumes based on ratio of Saturday peak hour trips to Saturday daily trips.
DRCOG = Denver Regional Council of Governments

Figure 4c
Year 2025
Sunday Background Traffic
Shadow Mountain Bike Park (LSC #220850)

Approximate Scale
Scale: 1"=1,200'

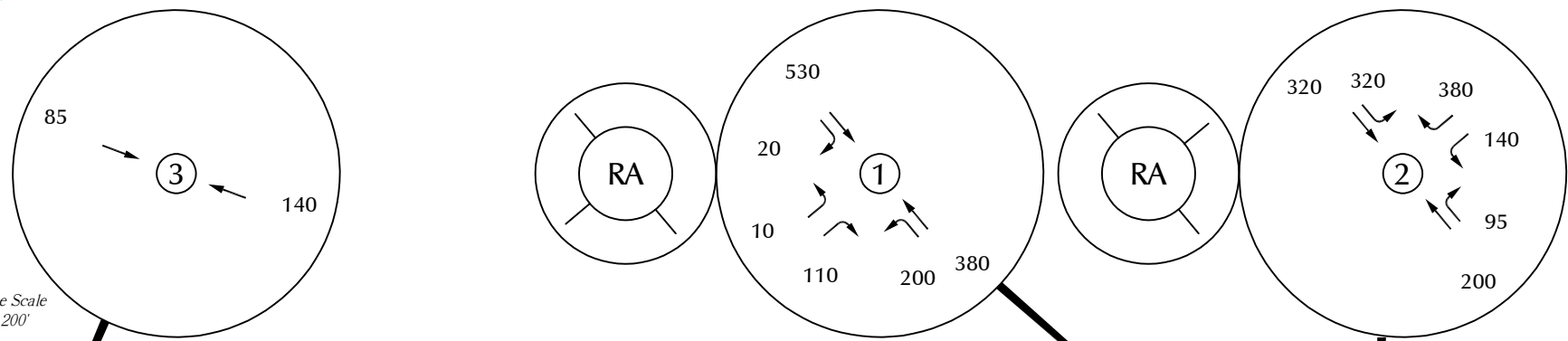

LEGEND:

⊥ = Stop Sign

30 = Weekday Afternoon Peak Hour Traffic (4:45–5:45pm)

Notes:

1. Assumes annual growth rate of one half percent on Shadow Mountain Drive and one percent on Highway 73 and Barkley Road.
2. Assumes roundabout control at Intersection #1 and #2 per feedback from Jefferson County.

Figure 5a

Year 2043
Weekday Background Traffic
Shadow Mountain Bike Park (LSC #220850)

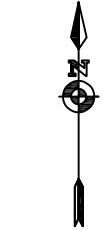

Approximate Scale
Scale: 1"=1,200'

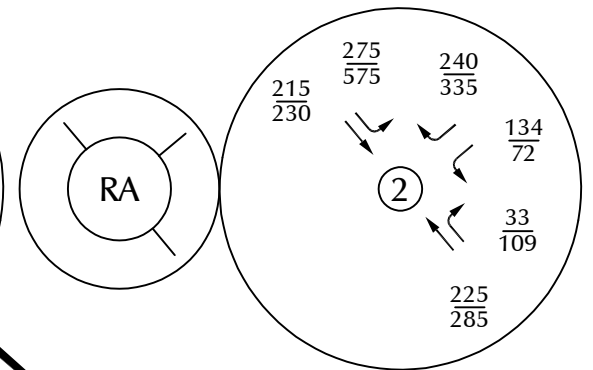
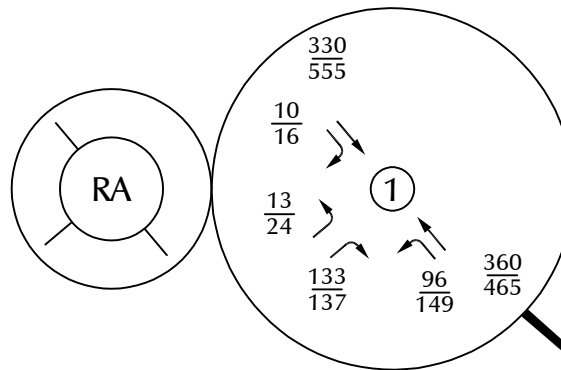
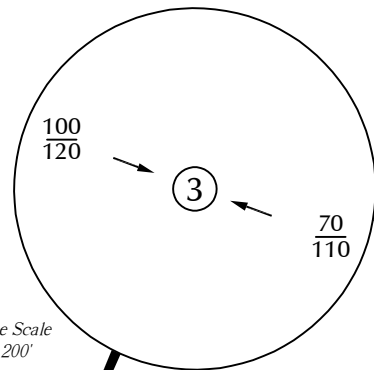

LEGEND:

⊥ = Stop Sign

$\frac{26}{35}$ = Saturday Morning Peak Hour Traffic (9:00am–10:00am)

$\frac{35}{26}$ = Saturday Midday Peak Hour Traffic (12:00pm–1:00pm)

Notes:

1. Assumes annual growth rate of one half percent on Shadow Mountain Drive and one percent on Highway 73 and Barkley Road.

2. Assumes roundabout control at Intersection #1 and #2 per feedback from Jefferson County.

Figure 5b

Year 2043

Saturday Background Traffic

Shadow Mountain Bike Park (LSC #220850)

Approximate Scale
Scale: 1"=1,200'

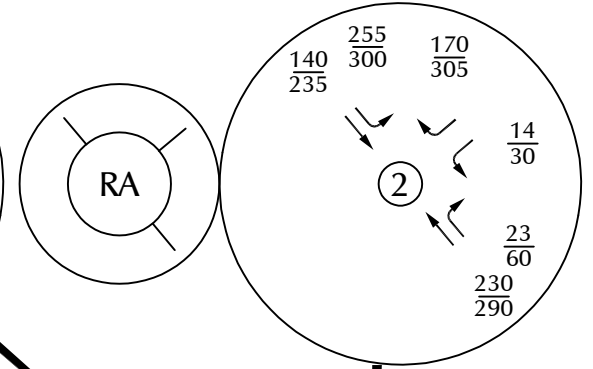
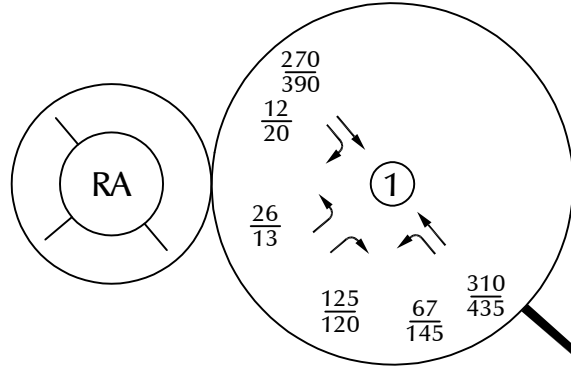
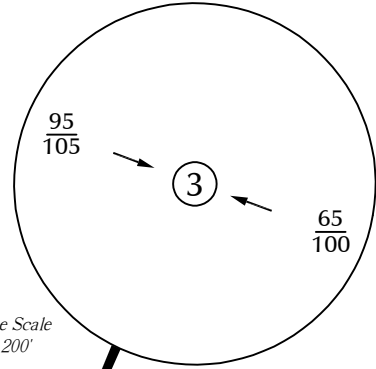

LEGEND:
 ↓ = Stop Sign
 $\frac{26}{35}$ = Sunday Morning Peak Hour Traffic (9:00am–10:00am)
 $\frac{35}{26}$ = Sunday Midday Peak Hour Traffic (12:30pm–1:30pm)

Notes:
 1. Assumes annual growth rate of one half percent on Shadow Mountain Drive and one percent on Highway 73 and Barkley Road.
 2. Assumes roundabout control at Intersection #1 and #2 per feedback from Jefferson County.

Figure 5c
Year 2043
Sunday Background Traffic
 Shadow Mountain Bike Park (LSC #220850)

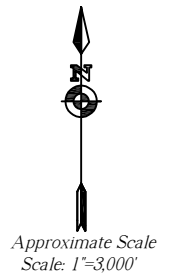

LEGEND:
 = Percent Directional Distribution

Figure 6
Directional Distribution of Site-Generated Traffic
 Shadow Mountain Bike Park (LSC #220850)

Approximate Scale
Scale: 1"=1,200'

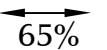
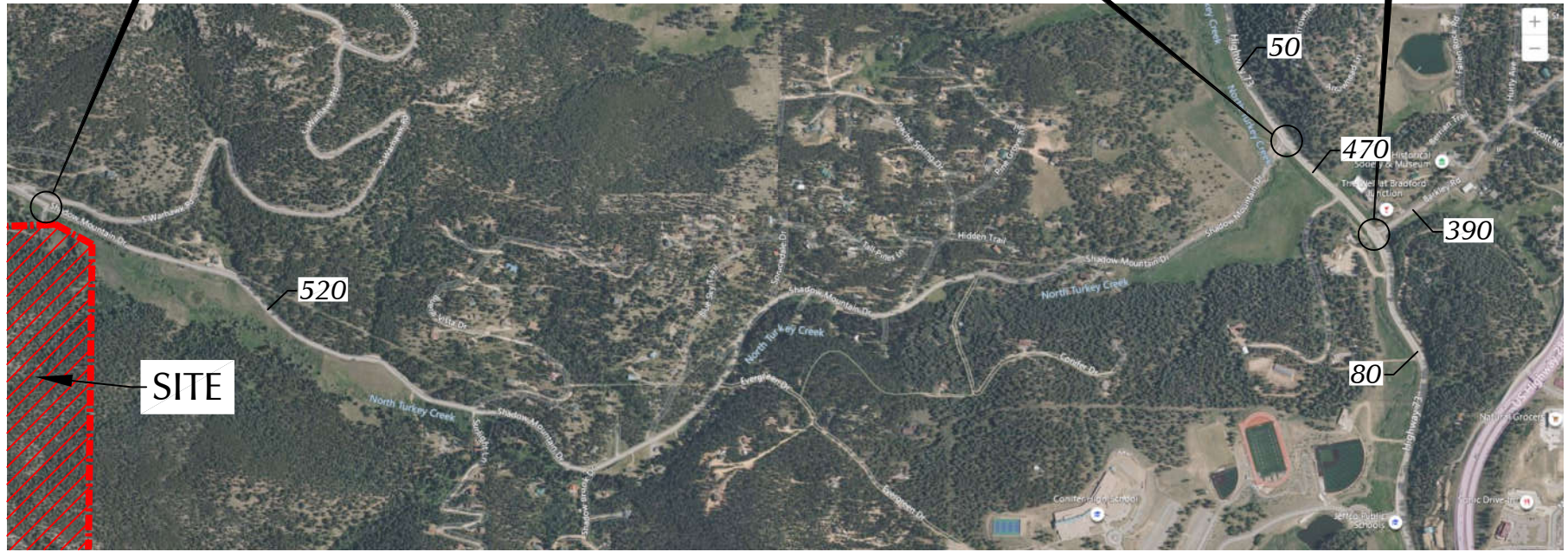
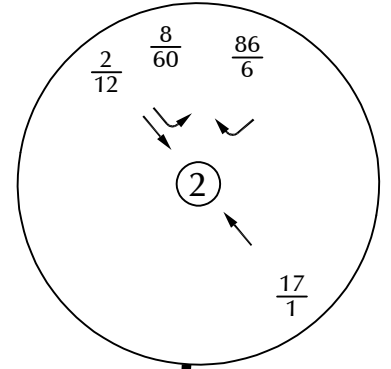
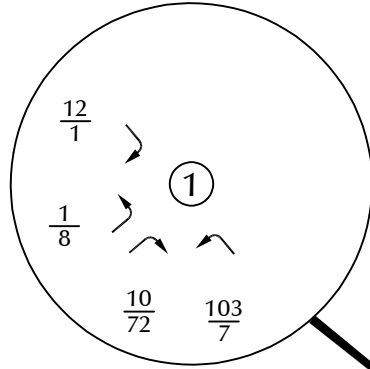
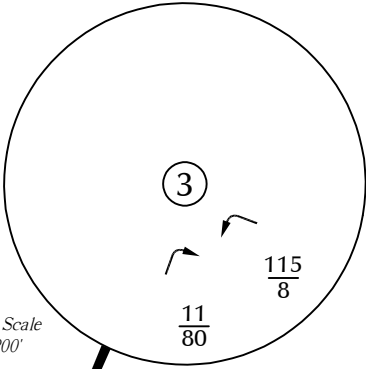

LEGEND:

$\frac{26}{35}$ = Weekday Morning Peak Hour Traffic
 = Weekday Afternoon Peak Hour Traffic

Figure 7a

Assignment of Weekday Site-Generated Traffic

Shadow Mountain Bike Park (LSC #220850)

Approximate Scale
Scale: 1"=1,200'

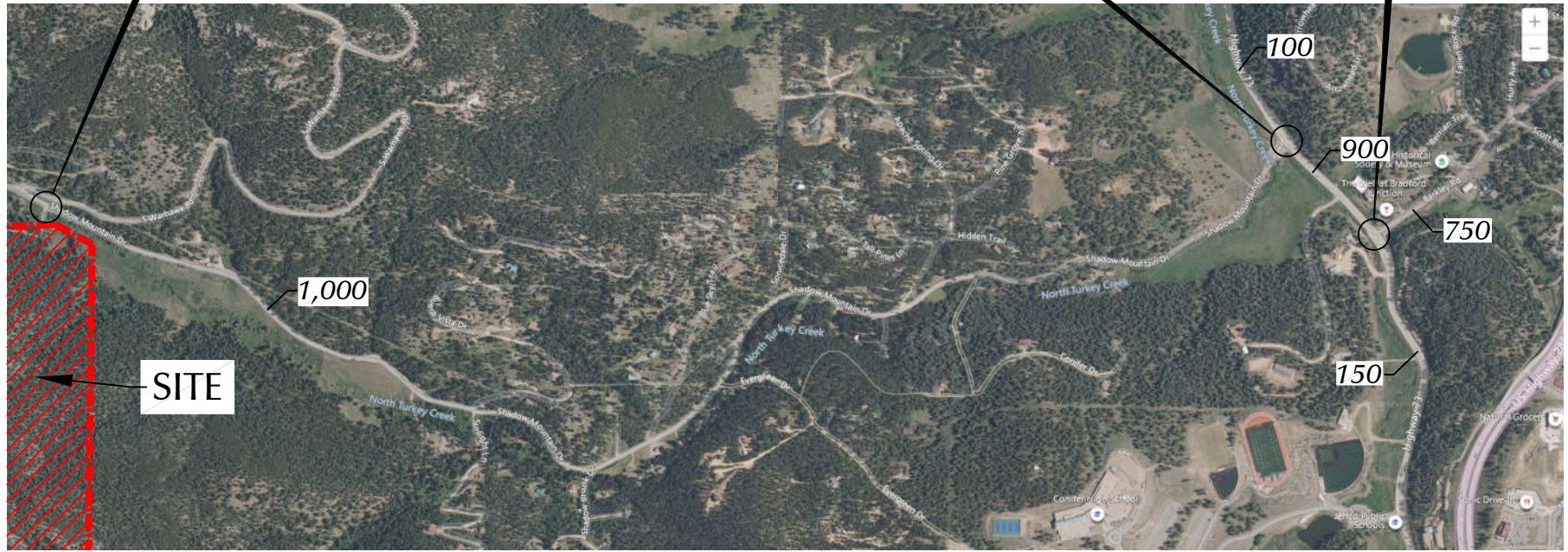
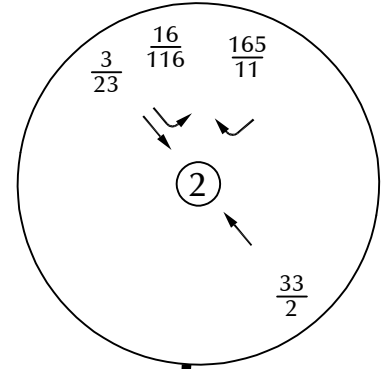
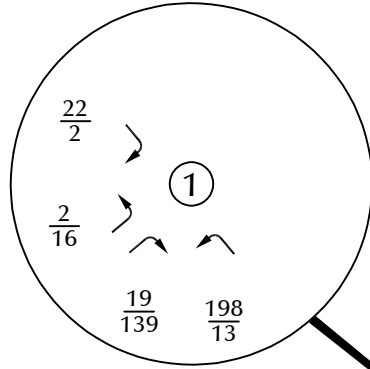
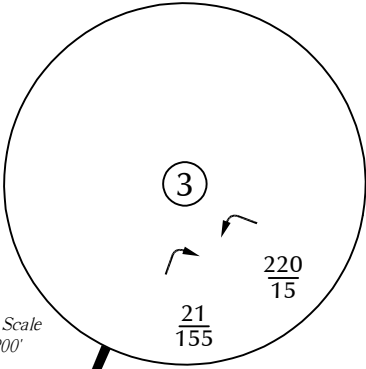

LEGEND:

$\frac{26}{35}$ = Weekend Morning Peak Hour Traffic
 $\frac{35}{26}$ = Weekend Afternoon Peak Hour Traffic

Figure 7b
**Assignment of
 Weekend Site-Generated Traffic**
 Shadow Mountain Bike Park (LSC #220850)



Approximate Scale
Scale: 1"=1,200'

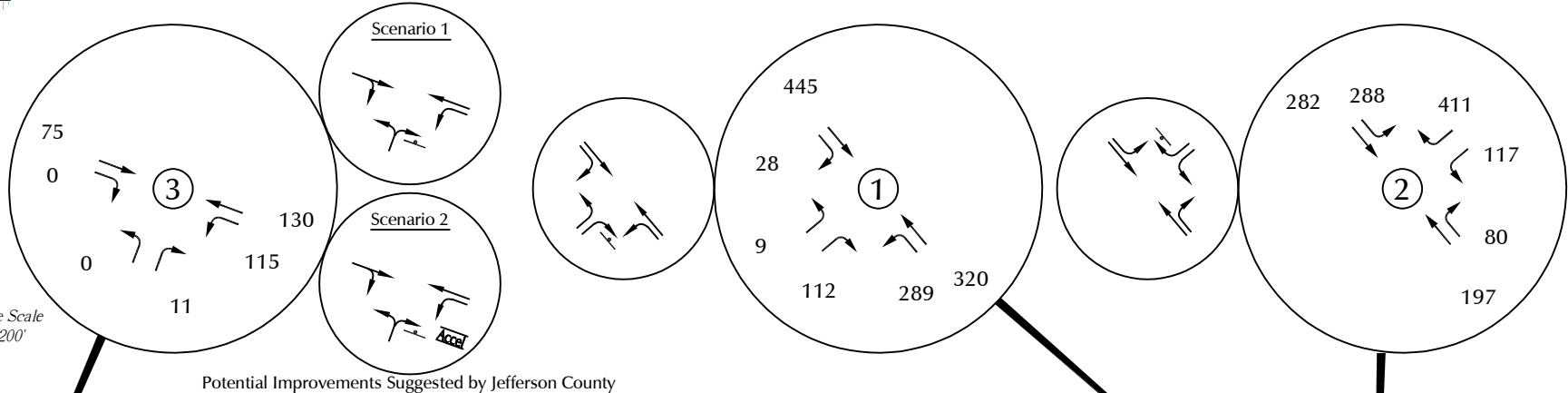

LEGEND:

⌋ = Stop Sign

30 = Weekday Afternoon Peak Hour Traffic (4:45–5:45pm)

Notes:

1. These volumes are the sum of the volumes in Figures 4a and 7a.

2. The potential site access improvements suggested by Jefferson County are a left-turn lane for ingress and a right-turn acceleration lane for egress. The acceleration lane is not expected to provide much benefit but a left-turn lane for ingress could be beneficial if there are no existing constraints preventing it such as right-of-way or wetland limitations. An appropriate length for a left-turn lane would be 280 feet plus a 140-foot transition taper and 45:1 redirect taper. The appropriate length for a right-turn acceleration lane is 380 feet plus a 180-foot transition taper.

Figure 8a

Year 2025 Weekday Total Traffic

Shadow Mountain Bike Park (LSC #220850)



Approximate Scale
Scale: 1"=1,200'

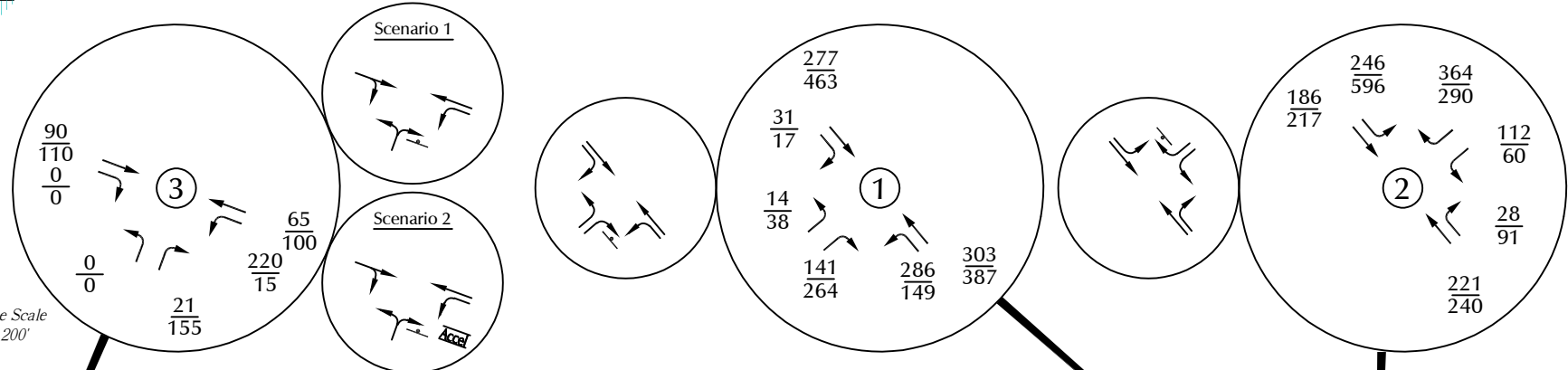

Potential Improvements Suggested by Jefferson County



LEGEND:

- ⊥ = Stop Sign
- $\frac{26}{35}$ = Saturday Morning Peak Hour Traffic (9:00am–10:00am)
- $\frac{35}{26}$ = Saturday Midday Peak Hour Traffic (12:00pm–1:00pm)

Notes:

1. These volumes are the sum of the volumes in Figures 4b and 7b.
2. The potential site access improvements suggested by Jefferson County are a left-turn lane for ingress and a right-turn acceleration lane for egress. The acceleration lane is not expected to provide much benefit but a left-turn lane for ingress could be beneficial if there are no existing constraints preventing it such as right-of-way or wetland limitations. An appropriate length for a left-turn lane would be 280 feet plus a 140-foot transition taper and 45:1 redirect taper. The appropriate length for a right-turn acceleration lane is 380 feet plus a 180-foot transition taper.

Figure 8b

Year 2025
Saturday Total Traffic
Shadow Mountain Bike Park (LSC #220850)



Approximate Scale
Scale: 1"=1,200'

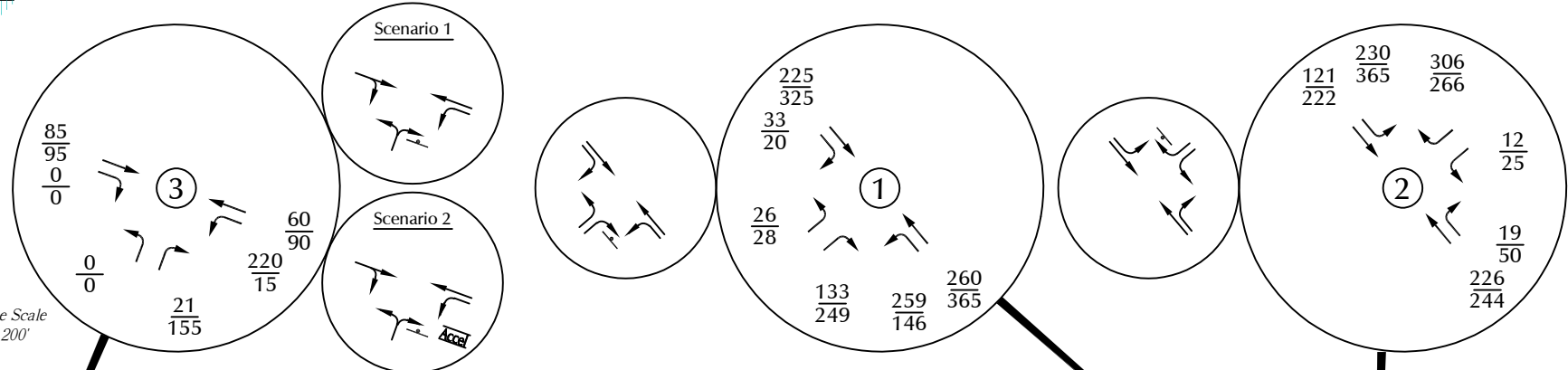

Potential Improvements Suggested by Jefferson County



LEGEND:

- ⊥ = Stop Sign
- $\frac{26}{35}$ = Sunday Morning Peak Hour Traffic (9:00am-10:00am)
- $\frac{35}{26}$ = Sunday Midday Peak Hour Traffic (12:30pm-1:30pm)

Notes:

1. These volumes are the sum of the volumes in Figures 4c and 7b.
2. The potential site access improvements suggested by Jefferson County are a left-turn lane for ingress and a right-turn acceleration lane for egress. The acceleration lane is not expected to provide much benefit but a left-turn lane for ingress could be beneficial if there are no existing constraints preventing it such as right-of-way or wetland limitations. An appropriate length for a left-turn lane would be 280 feet plus a 140-foot transition taper and 45:1 redirect taper. The appropriate length for a right-turn acceleration lane is 380 feet plus a 180-foot transition taper.

Figure 8c
Year 2025
Sunday Total Traffic
Shadow Mountain Bike Park (LSC #220850)

Approximate Scale
Scale: 1"=1,200'

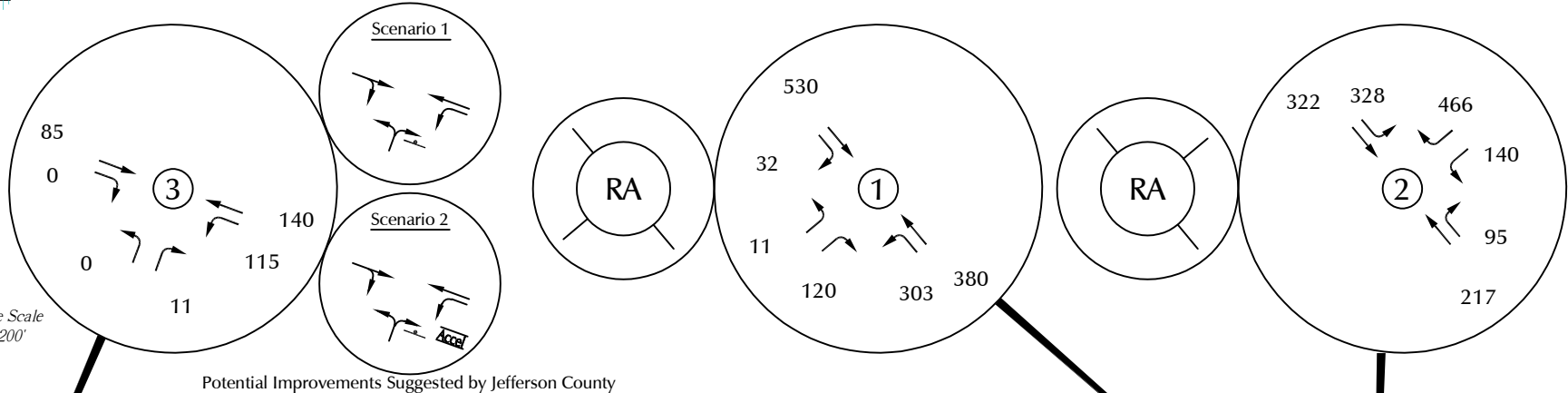

LEGEND:

⊥ = Stop Sign

30 = Weekday Afternoon Peak Hour Traffic (4:45–5:45pm)

Notes:

1. These volumes are the sum of the volumes in Figures 5a and 7a.
2. The potential site access improvements suggested by Jefferson County are a left-turn lane for ingress and a right-turn acceleration lane for egress. The acceleration lane is not expected to provide much benefit but a left-turn lane for ingress could be beneficial if there are no existing constraints preventing it such as right-of-way or wetland limitations. An appropriate length for a left-turn lane would be 280 feet plus a 140-foot transition taper and 45:1 redirect taper. The appropriate length for a right-turn acceleration lane is 380 feet plus a 180-foot transition taper.

Figure 9a

Year 2043 Weekday Total Traffic

Shadow Mountain Bike Park (LSC #220850)



Approximate Scale
Scale: 1"=1,200'

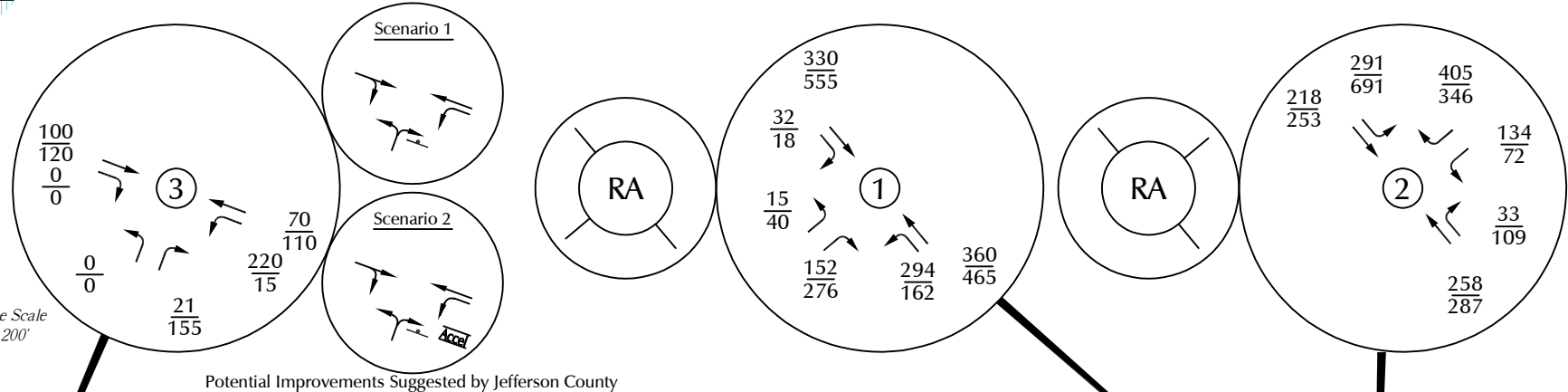

Potential Improvements Suggested by Jefferson County

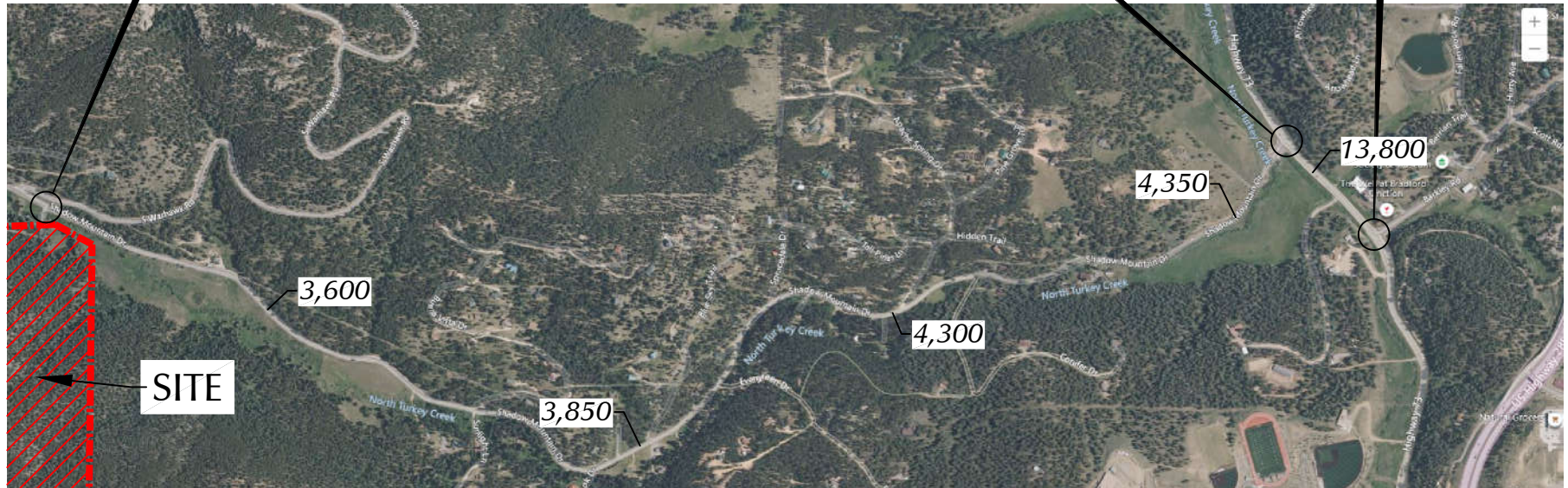

LEGEND:

- ↓ = Stop Sign
- $\frac{26}{35}$ = Saturday Morning Peak Hour Traffic (9:00am–10:00am)
- $\frac{35}{26}$ = Saturday Midday Peak Hour Traffic (12:00pm–1:00pm)

Notes:

1. These volumes are the sum of the volumes in Figures 5b and 7b.
2. The potential site access improvements suggested by Jefferson County are a left-turn lane for ingress and a right-turn acceleration lane for egress. The acceleration lane is not expected to provide much benefit but a left-turn lane for ingress could be beneficial if there are no existing constraints preventing it such as right-of-way or wetland limitations. An appropriate length for a left-turn lane would be 280 feet plus a 140-foot transition taper and 45:1 redirect taper. The appropriate length for a right-turn acceleration lane is 380 feet plus a 180-foot transition taper.

Figure 9b

Year 2043 Saturday Total Traffic

Shadow Mountain Bike Park (LSC #220850)



Approximate Scale
Scale: 1"=1,200'

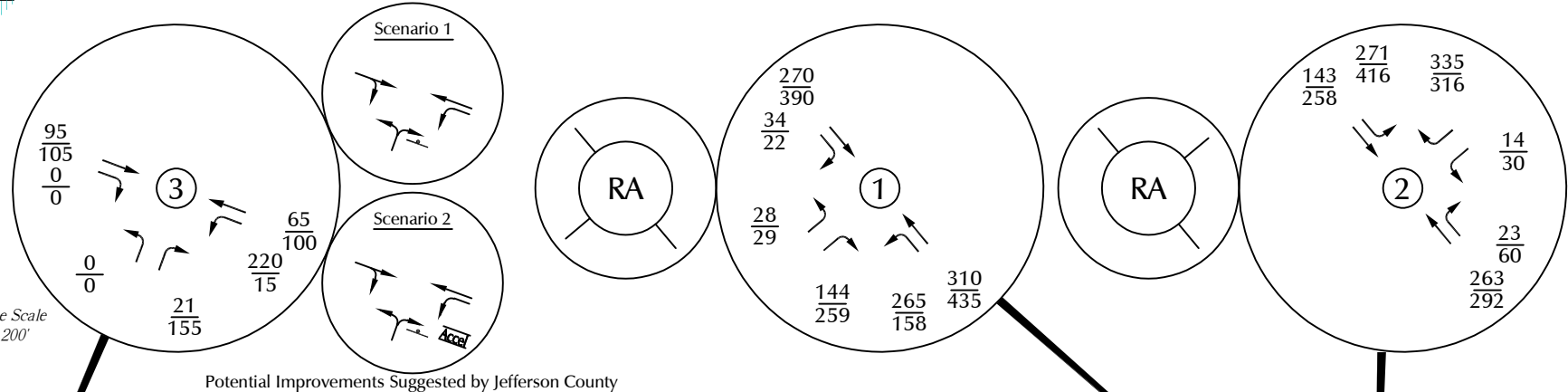

LEGEND:

- ⊥ = Stop Sign
- $\frac{26}{35}$ = Sunday Morning Peak Hour Traffic (9:00am–10:00am)
- $\frac{35}{26}$ = Sunday Midday Peak Hour Traffic (12:30pm–1:30pm)

Notes:

1. These volumes are the sum of the volumes in Figures 5c and 7b.
2. The potential site access improvements suggested by Jefferson County are a left-turn lane for ingress and a right-turn acceleration lane for egress. The acceleration lane is not expected to provide much benefit but a left-turn lane for ingress could be beneficial if there are no existing constraints preventing it such as right-of-way or wetland limitations. An appropriate length for a left-turn lane would be 280 feet plus a 140-foot transition taper and 45:1 redirect taper. The appropriate length for a right-turn acceleration lane is 380 feet plus a 180-foot transition taper.

Figure 9c

**Year 2043
Sunday Total Traffic**
Shadow Mountain Bike Park (LSC #220850)



Notes:

1. The recommended mitigation over time is to construct a single lane roundabout at both locations consistent with feedback from Jefferson County.
2. Some of the potential design constraints are labeled above.
3. The site-generated trips are expected to comprise about 15 percent of Saturday peak hour trips by 2043 at CR73/Shadow Mountain Drive. This percentage will be much lower on weekdays and in the off-season.
4. The site-generated trips are expected to comprise about 12 percent of Saturday peak hour trips by 2043 at CR 73/Barkley Road. This percentage will be much lower on weekdays and in the off-season.

Figure 10

Potential Improvements Along CH 73 Based on County Feedback

Shadow Mountain Bike Park (LSC #220850)

COUNTER MEASURES INC.

1889 YORK STREET
DENVER.COLORADO
303-333-7409

N/S STREET: HWY 73
E/W STREET: BARKLEY RD
CITY: CONIFER
COUNTY: JEFFERSON

File Name : HWY73BARK
Site Code : 00000025
Start Date : 8/24/2022
Page No : 2

Start Time	HWY 73 Southbound					BARKLEY RD Westbound					HWY 73 Northbound					NO ACCESS Eastbound					Int. Total
	Left	Thru	Right	Peds	App. Total	Left	Thru	Right	Peds	App. Total	Left	Thru	Right	Peds	App. Total	Left	Thru	Right	Peds	App. Total	
Peak Hour From 04:00 PM to 05:45 PM - Peak 1 of 1																					
Intersection	04:45 PM																				
Volume	274	276	0	0	550	114	1	315	0	430	0	177	78	0	255	0	0	0	0	0	1235
Percent	49.8	50.2	0.0	0.0		26.5	0.2	73.3	0.0		0.0	69.4	30.6	0.0		0.0	0.0	0.0	0.0		
05:00 Volume	66	76	0	0	142	32	1	84	0	117	0	43	16	0	59	0	0	0	0	0	318
Peak Factor																					
High Int. Volume	05:00 PM					04:45 PM					05:30 PM					3:45:00 PM					
Peak Factor	0.968					0.888					0.777										0.971

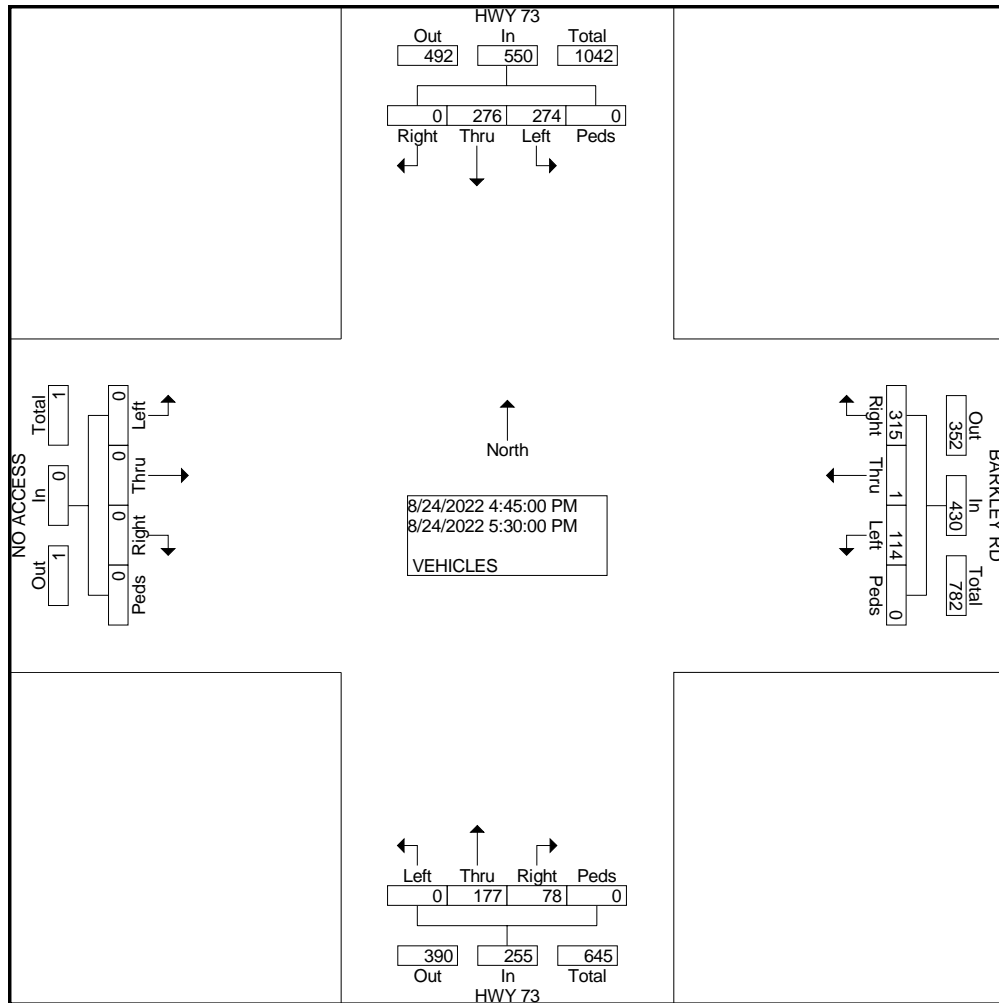

COUNTER MEASURES INC.

1889 YORK STREET
DENVER.COLORADO
303-333-7409

N/S STREET: SHADOW MTN DR
E/W STREET: HWY 73
CITY: CONIFER
COUNTY: JEFFERSON

File Name : SHAD73PM2
Site Code : 00000020
Start Date : 8/24/2022
Page No : 1

Groups Printed- VEHICLES

Start Time	HWY 73 Southbound				NO ACCESS Westbound				HWY 73 Northbound				SHADOW MTN DR Eastbound				Int. Total
	Left	Thru	Right	Peds	Left	Thru	Right	Peds	Left	Thru	Right	Peds	Left	Thru	Right	Peds	
Factor	1.0	1.0	1.0	1.0	1.0	1.0	1.0	1.0	1.0	1.0	1.0	1.0	1.0	1.0	1.0	1.0	
04:00 PM	0	101	4	0	0	0	0	0	30	85	0	0	7	0	20	0	247
04:15 PM	0	98	6	0	0	0	0	0	44	77	0	1	4	0	27	0	257
04:30 PM	0	95	6	0	0	0	0	0	40	82	0	0	7	0	19	0	249
04:45 PM	0	101	6	0	0	0	0	0	56	73	0	0	6	0	25	0	267
Total	0	395	22	0	0	0	0	0	170	317	0	1	24	0	91	0	1020
05:00 PM	0	121	4	0	0	0	0	0	32	89	1	0	1	0	23	0	271
05:15 PM	0	104	5	0	0	0	0	0	45	68	0	0	1	0	30	0	253
05:30 PM	0	107	1	0	0	0	0	0	50	80	0	0	0	0	22	0	260
05:45 PM	0	101	7	0	0	0	0	0	43	91	0	0	1	0	24	0	267
Total	0	433	17	0	0	0	0	0	170	328	1	0	3	0	99	0	1051
Grand Total	0	828	39	0	0	0	0	0	340	645	1	1	27	0	190	0	2071
Apprch %	0.0	95.5	4.5	0.0	0.0	0.0	0.0	0.0	34.4	65.3	0.1	0.1	12.4	0.0	87.6	0.0	
Total %	0.0	40.0	1.9	0.0	0.0	0.0	0.0	0.0	16.4	31.1	0.0	0.0	1.3	0.0	9.2	0.0	

COUNTER MEASURES INC.

1889 YORK STREET
DENVER, COLORADO
303-333-7409

N/S STREET: SHADOW MTN DR
E/W STREET: HWY 73
CITY: CONIFER
COUNTY: JEFFERSON

File Name : SHAD73PM2
Site Code : 00000020
Start Date : 8/24/2022
Page No : 2

Start Time	HWY 73 Southbound					NO ACCESS Westbound					HWY 73 Northbound					SHADOW MTN DR Eastbound					Int. Total
	Left	Thru	Right	Peds	App. Total	Left	Thru	Right	Peds	App. Total	Left	Thru	Right	Peds	App. Total	Left	Thru	Right	Peds	App. Total	
Peak Hour From 04:00 PM to 05:45 PM - Peak 1 of 1																					
Intersection	04:45 PM																				
Volume	0	433	16	0	449	0	0	0	0	0	183	310	1	0	494	8	0	100	0	108	1051
Percent	0.0	96.4	3.6	0.0		0.0	0.0	0.0	0.0		37.0	62.8	0.2	0.0		7.4	0.0	92.6	0.0		
05:00 Volume	0	121	4	0	125	0	0	0	0	0	32	89	1	0	122	1	0	23	0	24	271
Peak Factor	0.970																				
High Int.	05:00 PM																				
Volume	0	121	4	0	125	3:45:00 PM					05:30 PM					04:45 PM					
Peak Factor	0.898										0.950					0.871					

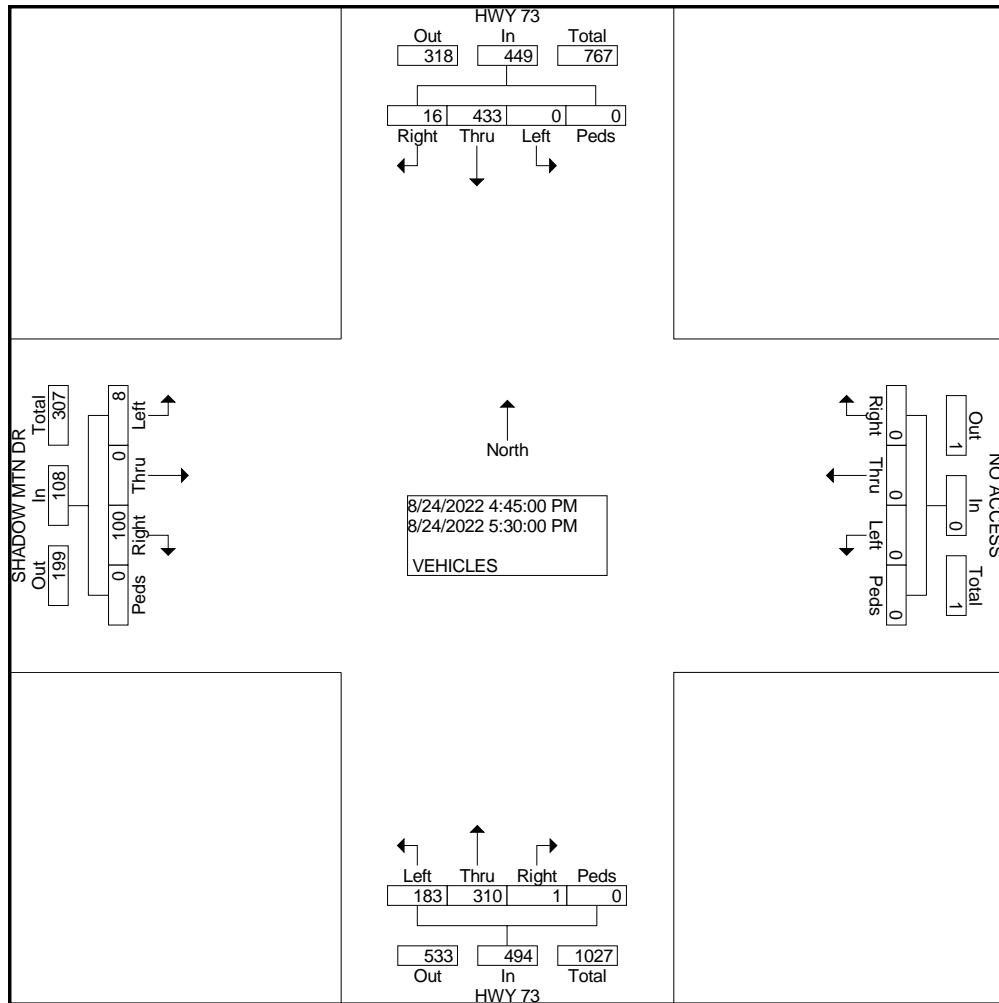

COUNTER MEASURES INC.

1889 YORK STREET
DENVER.COLORADO
303-333-7409

N/S STREET: HWY 73
E/W STREET: BARKLEY RD
CITY: CONIFER
COUNTY: JEFFERSON

File Name : HWY73BARK0827
Site Code : 00000013
Start Date : 8/27/2022
Page No : 1

Groups Printed- VEHICLES

Start Time	HWY 73 Southbound			BARKLEY RD Westbound			HWY 73 Northbound			NO ACCESS Eastbound			Int. Total
	Left	Thru	Right	Left	Thru	Right	Left	Thru	Right	Left	Thru	Right	
Factor	1.0	1.0	1.0	1.0	1.0	1.0	1.0	1.0	1.0	1.0	1.0	1.0	
08:00 AM	41	22	0	5	0	28	0	24	2	0	0	0	122
08:15 AM	40	26	0	5	0	30	0	37	3	0	0	0	141
08:30 AM	30	36	0	19	1	42	0	30	9	0	0	0	167
08:45 AM	63	35	0	14	1	36	0	39	16	0	0	0	204
Total	174	119	0	43	2	136	0	130	30	0	0	0	634
09:00 AM	44	25	0	8	0	34	0	31	7	0	0	0	149
09:15 AM	62	41	0	31	0	55	0	45	4	0	0	0	238
09:30 AM	55	48	0	24	1	53	0	54	10	0	0	0	245
09:45 AM	62	64	0	46	4	51	0	52	6	0	0	0	285
Total	223	178	0	109	5	193	0	182	27	0	0	0	917
12:00 PM	67	44	0	21	0	58	0	63	17	0	0	0	270
12:15 PM	71	44	0	15	0	75	0	54	7	0	0	0	266
12:30 PM	241	52	0	5	0	56	0	48	25	0	0	0	427
12:45 PM	88	48	0	17	0	82	0	66	39	0	0	0	340
Total	467	188	0	58	0	271	0	231	88	0	0	0	1303
01:00 PM	70	60	0	18	1	59	0	43	18	0	0	0	269
01:15 PM	63	60	0	4	0	70	0	51	10	0	0	0	258
01:30 PM	75	43	0	7	0	73	0	52	12	0	0	0	262
01:45 PM	74	52	0	17	0	165	0	49	10	0	0	0	367
Total	282	215	0	46	1	367	0	195	50	0	0	0	1156
Grand Total	1146	700	0	256	8	967	0	738	195	0	0	0	4010
Apprch %	62.1	37.9	0.0	20.8	0.6	78.6	0.0	79.1	20.9	0.0	0.0	0.0	
Total %	28.6	17.5	0.0	6.4	0.2	24.1	0.0	18.4	4.9	0.0	0.0	0.0	

COUNTER MEASURES INC.

1889 YORK STREET
DENVER, COLORADO
303-333-7409

N/S STREET: HWY 73
E/W STREET: BARKLEY RD
CITY: CONIFER
COUNTY: JEFFERSON

File Name : HWY73BARK0827
Site Code : 00000013
Start Date : 8/27/2022
Page No : 2

Start Time	HWY 73 Southbound				BARKLEY RD Westbound				HWY 73 Northbound				NO ACCESS Eastbound				Int. Total
	Left	Thru	Right	App. Total	Left	Thru	Right	App. Total	Left	Thru	Right	App. Total	Left	Thru	Right	App. Total	
Peak Hour From 08:00 AM to 09:45 AM - Peak 1 of 1																	
Intersection	09:00 AM																
Volume	223	178	0	401	109	5	193	307	0	182	27	209	0	0	0	0	917
Percent	55.6	44.4	0.0		35.5	1.6	62.9		0.0	87.1	12.9		0.0	0.0	0.0		
Volume	62	64	0	126	46	4	51	101	0	52	6	58	0	0	0	0	285
Peak Factor	0.804																
High Int.	09:45 AM				09:45 AM				09:30 AM				7:45:00 AM				
Volume	62	64	0	126	46	4	51	101	0	54	10	64					
Peak Factor	0.796								0.760				0.816				

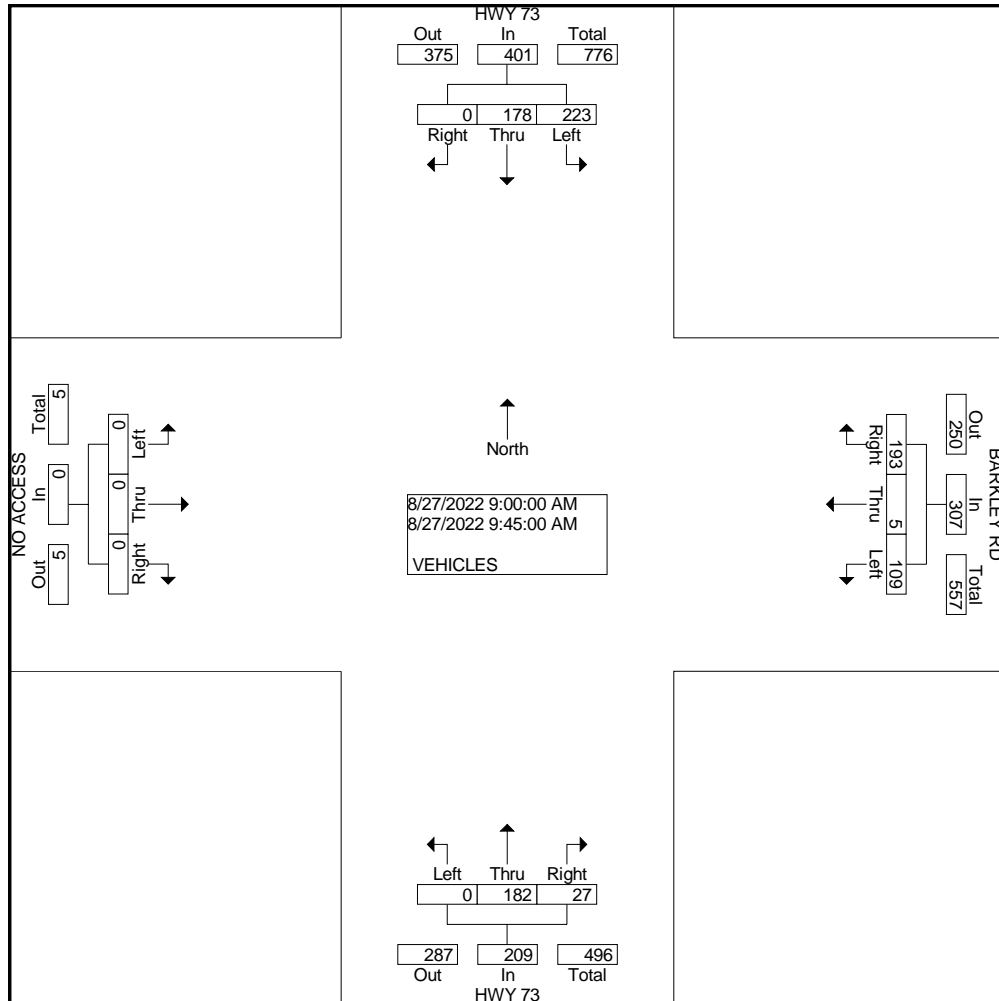

COUNTER MEASURES INC.

1889 YORK STREET
DENVER, COLORADO
303-333-7409

N/S STREET: HWY 73
E/W STREET: BARKLEY RD
CITY: CONIFER
COUNTY: JEFFERSON

File Name : HWY73BARK0827
Site Code : 00000013
Start Date : 8/27/2022
Page No : 3

Start Time	HWY 73 Southbound				BARKLEY RD Westbound				HWY 73 Northbound				NO ACCESS Eastbound				Int. Total
	Left	Thru	Right	App. Total	Left	Thru	Right	App. Total	Left	Thru	Right	App. Total	Left	Thru	Right	App. Total	
Peak Hour From 12:00 PM to 01:45 PM - Peak 1 of 1																	
Intersection	12:00 PM																
Volume	467	188	0	655	58	0	271	329	0	231	88	319	0	0	0	0	1303
Percent	71.3	28.7	0.0		17.6	0.0	82.4		0.0	72.4	27.6		0.0	0.0	0.0		
12:30 Volume	241	52	0	293	5	0	56	61	0	48	25	73	0	0	0	0	427
Peak Factor	0.763																
High Int.	12:30 PM																
Volume	241	52	0	293	17	0	82	99	0	66	39	105					
Peak Factor	0.559				0.831				0.760								

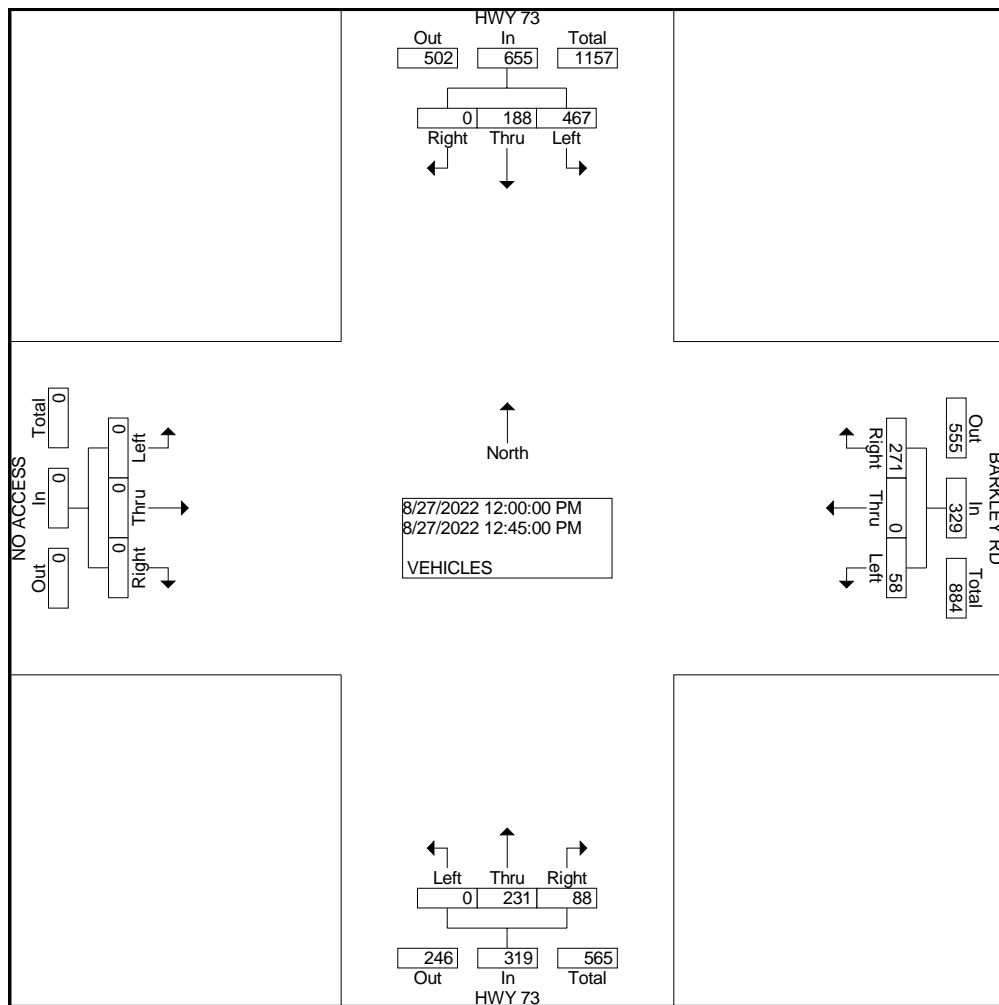

COUNTER MEASURES INC.

1889 YORK STREET
DENVER.COLORADO
303-333-7409

N/S STREET: HWY 73
E/W STREET: BARKLEY RD
CITY: CONIFER
COUNTY: JEFFERSON

File Name : HWY73BARK0828
Site Code : 00000013
Start Date : 8/28/2022
Page No : 1

Groups Printed- VEHICLES

Start Time	HWY 73 Southbound			BARKLEY RD Westbound			HWY 73 Northbound			NO ACCESS Eastbound			Int. Total
	Left	Thru	Right	Left	Thru	Right	Left	Thru	Right	Left	Thru	Right	
Factor	1.0	1.0	1.0	1.0	1.0	1.0	1.0	1.0	1.0	1.0	1.0	1.0	
08:00 AM	37	18	0	0	0	25	0	19	4	0	0	0	103
08:15 AM	31	14	0	3	0	22	0	23	1	0	0	0	94
08:30 AM	31	25	0	1	0	29	0	26	6	0	0	0	118
08:45 AM	38	34	0	0	0	26	0	35	12	0	0	0	145
Total	137	91	0	4	0	102	0	103	23	0	0	0	460
09:00 AM	33	27	0	1	0	28	0	27	4	0	0	0	120
09:15 AM	74	23	0	1	0	36	0	36	4	0	0	0	174
09:30 AM	47	27	0	4	0	29	0	61	6	0	0	0	174
09:45 AM	54	38	0	6	0	44	0	63	4	0	0	0	209
Total	208	115	0	12	0	137	0	187	18	0	0	0	677
12:00 PM	52	59	0	12	0	62	0	48	10	0	0	0	243
12:15 PM	63	58	0	6	0	38	0	58	10	0	0	0	233
12:30 PM	53	51	0	7	0	59	0	57	10	0	0	0	237
12:45 PM	54	43	0	8	0	76	0	57	16	0	0	0	254
Total	222	211	0	33	0	235	0	220	46	0	0	0	967
01:00 PM	79	46	0	5	0	60	0	65	6	0	0	0	261
01:15 PM	56	53	0	4	1	53	0	56	17	0	0	0	240
01:30 PM	45	45	0	5	1	57	0	51	10	0	0	0	214
01:45 PM	52	41	0	0	0	52	0	45	12	0	0	0	202
Total	232	185	0	14	2	222	0	217	45	0	0	0	917
Grand Total	799	602	0	63	2	696	0	727	132	0	0	0	3021
Apprch %	57.0	43.0	0.0	8.3	0.3	91.5	0.0	84.6	15.4	0.0	0.0	0.0	
Total %	26.4	19.9	0.0	2.1	0.1	23.0	0.0	24.1	4.4	0.0	0.0	0.0	

COUNTER MEASURES INC.

1889 YORK STREET
DENVER, COLORADO
303-333-7409

N/S STREET: HWY 73
E/W STREET: BARKLEY RD
CITY: CONIFER
COUNTY: JEFFERSON

File Name : HWY73BARK0828
Site Code : 00000013
Start Date : 8/28/2022
Page No : 2

Start Time	HWY 73 Southbound				BARKLEY RD Westbound				HWY 73 Northbound				NO ACCESS Eastbound				Int. Total
	Left	Thru	Right	App. Total	Left	Thru	Right	App. Total	Left	Thru	Right	App. Total	Left	Thru	Right	App. Total	
Peak Hour From 08:00 AM to 09:45 AM - Peak 1 of 1																	
Intersection	09:00 AM																
Volume	208	115	0	323	12	0	137	149	0	187	18	205	0	0	0	0	677
Percent	64.4	35.6	0.0		8.1	0.0	91.9		0.0	91.2	8.8		0.0	0.0	0.0		
09:45	Volume																
Volume	54	38	0	92	6	0	44	50	0	63	4	67	0	0	0	0	209
Peak Factor	0.810																
High Int.	09:15 AM				09:45 AM				09:30 AM				7:45:00 AM				
Volume	74	23	0	97	6	0	44	50	0	61	6	67					
Peak Factor	0.832				0.745				0.765								

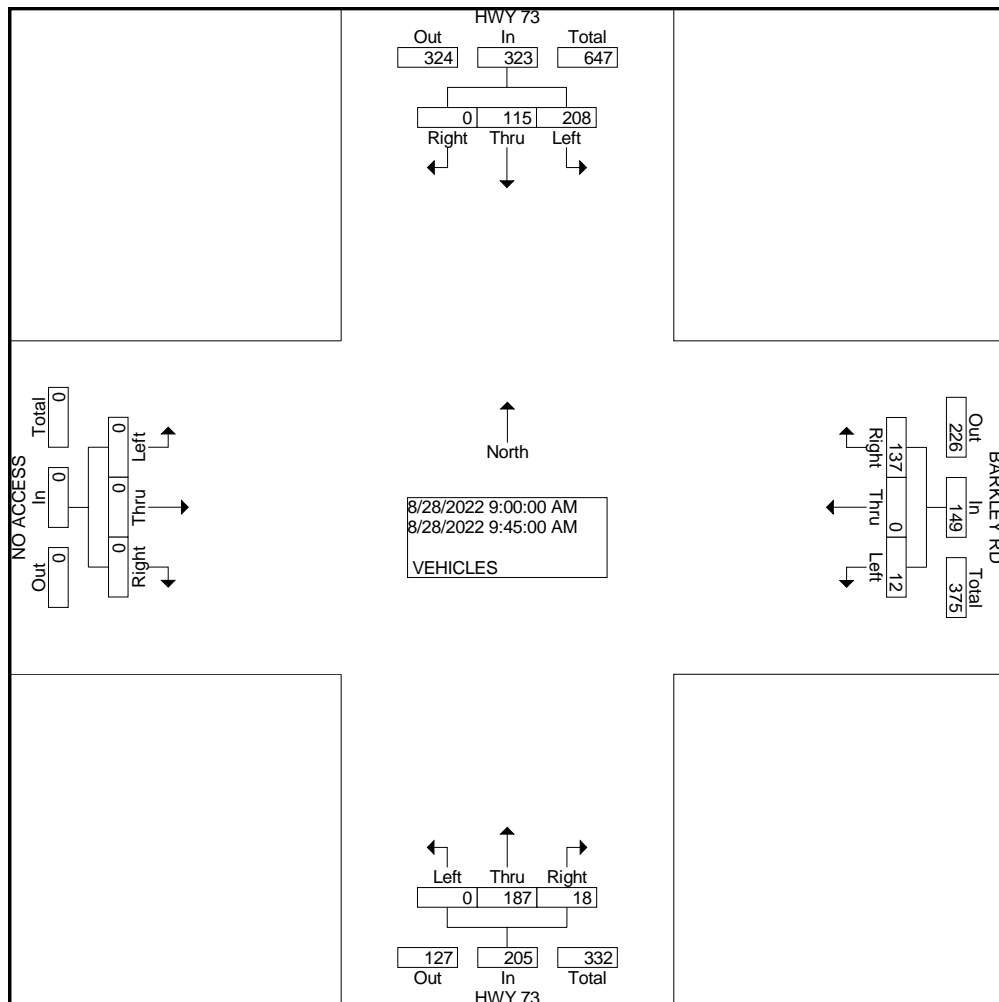

COUNTER MEASURES INC.

1889 YORK STREET
DENVER, COLORADO
303-333-7409

N/S STREET: HWY 73
E/W STREET: BARKLEY RD
CITY: CONIFER
COUNTY: JEFFERSON

File Name : HWY73BARK0828
Site Code : 00000013
Start Date : 8/28/2022
Page No : 3

Start Time	HWY 73 Southbound				BARKLEY RD Westbound				HWY 73 Northbound				NO ACCESS Eastbound				Int. Total
	Left	Thru	Right	App. Total	Left	Thru	Right	App. Total	Left	Thru	Right	App. Total	Left	Thru	Right	App. Total	
Peak Hour From 12:00 PM to 01:45 PM - Peak 1 of 1																	
Intersection	12:30 PM																
Volume	242	193	0	435	24	1	248	273	0	235	49	284	0	0	0	0	992
Percent	55.6	44.4	0.0		8.8	0.4	90.8		0.0	82.7	17.3		0.0	0.0	0.0		
01:00																	
Volume	79	46	0	125	5	0	60	65	0	65	6	71	0	0	0	0	261
Peak Factor	0.950																
High Int.	01:00 PM																
Volume	79	46	0	125	8	0	76	84	0	57	16	73					
Peak Factor	0.870				0.813				0.973								

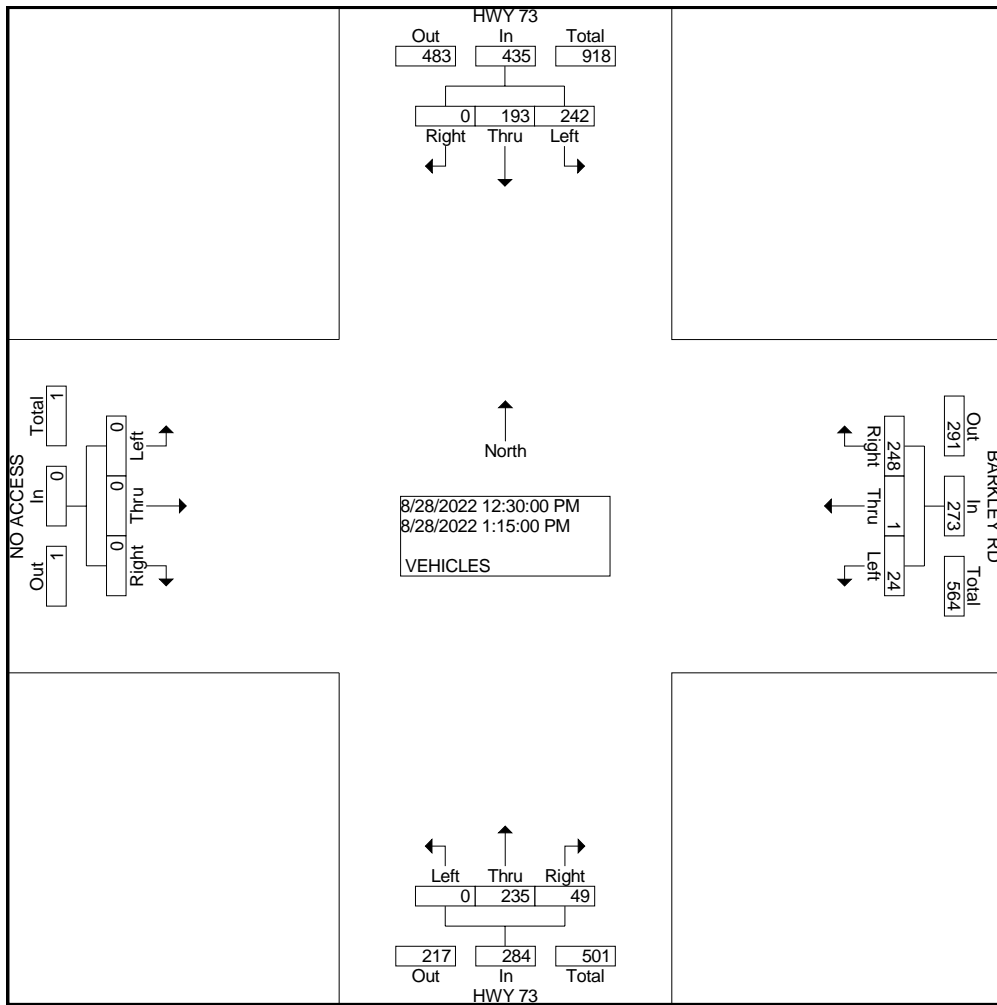

COUNTER MEASURES INC.

1889 YORK STREET
DENVER.COLORADO
303-333-7409

N/S STREET: HWY 73
E/W STREET: SHADOW MOUNTAIN DR
CITY: CONIFER
COUNTY: JEFFERSON

File Name : HWY73SHADOW 0827
Site Code : 00000011
Start Date : 8/27/2022
Page No : 1

Groups Printed- VEHICLES

Start Time	HWY 73 Southbound			NO ACCESS Westbound			HWY 73 Northbound			SHADOW MTN DR Eastbound			Int. Total
	Left	Thru	Right	Left	Thru	Right	Left	Thru	Right	Left	Thru	Right	
Factor	1.0	1.0	1.0	1.0	1.0	1.0	1.0	1.0	1.0	1.0	1.0	1.0	
08:00 AM	0	37	1	0	0	0	10	40	0	6	0	20	114
08:15 AM	0	44	1	0	0	0	16	55	0	3	0	22	141
08:30 AM	0	43	2	0	0	0	16	60	0	6	0	32	159
08:45 AM	0	68	2	0	0	0	21	50	0	6	0	22	169
Total	0	192	6	0	0	0	63	205	0	21	0	96	583
09:00 AM	0	39	1	0	1	0	14	47	0	1	0	29	132
09:15 AM	0	71	4	0	0	0	23	81	0	5	0	30	214
09:30 AM	0	75	2	0	0	0	24	94	0	1	0	29	225
09:45 AM	0	84	2	0	0	0	26	72	0	5	0	32	221
Total	0	269	9	0	1	0	87	294	0	12	0	120	792
12:00 PM	0	78	3	0	0	0	30	89	0	6	0	29	235
12:15 PM	0	72	3	0	0	0	38	89	0	2	0	29	233
12:30 PM	0	218	3	0	0	0	31	83	0	6	0	24	365
12:45 PM	0	81	6	0	0	0	35	115	0	8	0	41	286
Total	0	449	15	0	0	0	134	376	0	22	0	123	1119
01:00 PM	0	99	4	0	0	0	33	71	0	5	0	34	246
01:15 PM	0	82	5	0	0	0	38	94	0	6	0	30	255
01:30 PM	0	89	7	0	0	0	30	88	0	4	0	32	250
01:45 PM	0	95	2	0	0	0	32	176	0	4	0	25	334
Total	0	365	18	0	0	0	133	429	0	19	0	121	1085
Grand Total	0	1275	48	0	1	0	417	1304	0	74	0	460	3579
Apprch %	0.0	96.4	3.6	0.0	100.0	0.0	24.2	75.8	0.0	13.9	0.0	86.1	
Total %	0.0	35.6	1.3	0.0	0.0	0.0	11.7	36.4	0.0	2.1	0.0	12.9	

COUNTER MEASURES INC.

1889 YORK STREET
DENVER, COLORADO
303-333-7409

N/S STREET: HWY 73
E/W STREET: SHADOW MOUNTAIN DR
CITY: CONIFER
COUNTY: JEFFERSON

File Name : HWY73SHADOW 0827
Site Code : 00000011
Start Date : 8/27/2022
Page No : 2

Start Time	HWY 73 Southbound				NO ACCESS Westbound				HWY 73 Northbound				SHADOW MTN DR Eastbound				Int. Total
	Left	Thru	Right	App. Total	Left	Thru	Right	App. Total	Left	Thru	Right	App. Total	Left	Thru	Right	App. Total	
Peak Hour From 09:00 AM to 09:45 AM - Peak 1 of 1																	
Intersection	09:00 AM																
Volume	0	269	9	278	0	1	0	1	87	294	0	381	12	0	120	132	792
Percent	0.0	96.8	3.2		0.0	100.0	0.0		22.8	77.2	0.0		9.1	0.0	90.9		
09:30 Volume	0	75	2	77	0	0	0	0	24	94	0	118	1	0	29	30	225
Peak Factor	0.880																
High Int.	09:45 AM																
Volume	0	84	2	86	0	1	0	1	24	94	0	118	5	0	32	37	
Peak Factor	0.808				0.250				0.807				0.892				

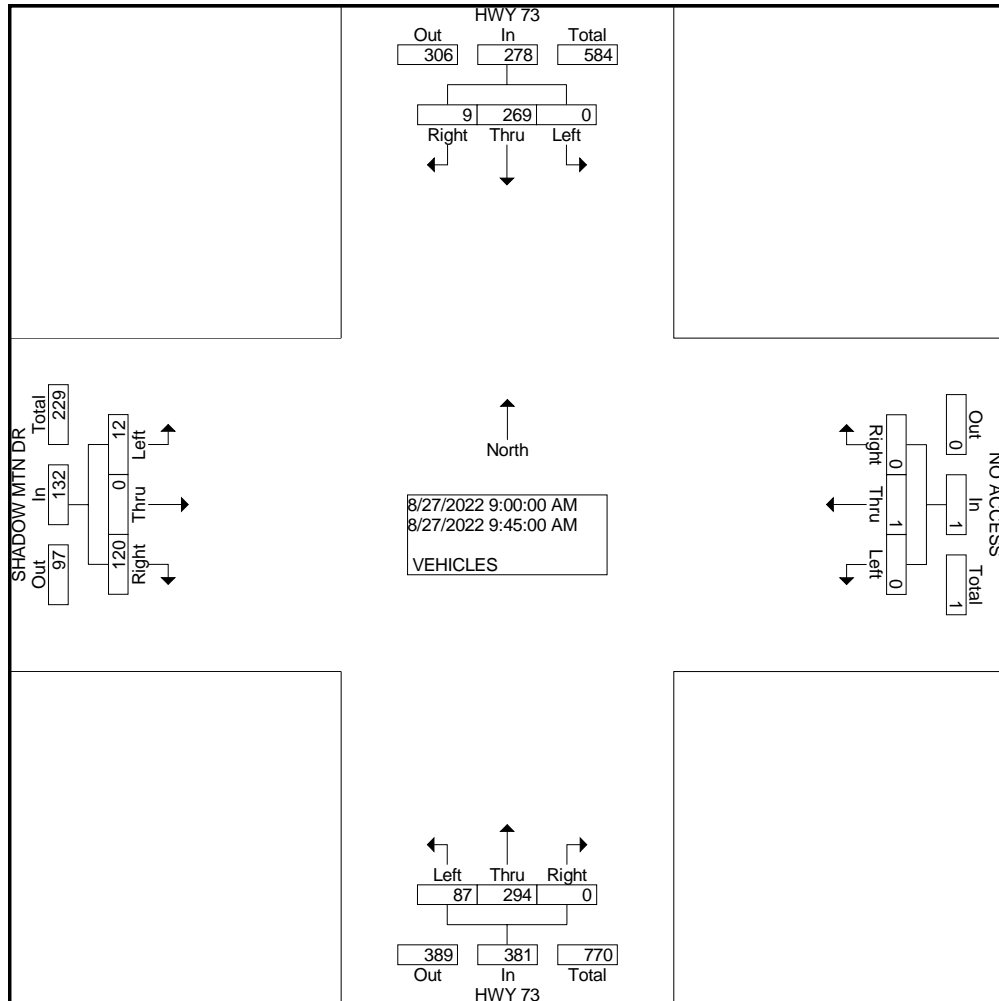

COUNTER MEASURES INC.

1889 YORK STREET
DENVER, COLORADO
303-333-7409

N/S STREET: HWY 73
E/W STREET: SHADOW MOUNTAIN DR
CITY: CONIFER
COUNTY: JEFFERSON

File Name : HWY73SHADOW 0827
Site Code : 00000011
Start Date : 8/27/2022
Page No : 3

Start Time	HWY 73 Southbound				NO ACCESS Westbound				HWY 73 Northbound				SHADOW MTN DR Eastbound				Int. Total
	Left	Thru	Right	App. Total	Left	Thru	Right	App. Total	Left	Thru	Right	App. Total	Left	Thru	Right	App. Total	
Peak Hour From 12:00 PM to 12:45 PM - Peak 1 of 1																	
Intersection	12:00 PM																
Volume	0	449	15	464	0	0	0	0	134	376	0	510	22	0	123	145	1119
Percent	0.0	96.8	3.2		0.0	0.0	0.0		26.3	73.7	0.0		15.2	0.0	84.8		
12:30																	
Volume	0	218	3	221	0	0	0	0	31	83	0	114	6	0	24	30	365
Peak Factor	0.766																
High Int.	12:30 PM																
Volume	0	218	3	221	0	0	0	0	35	115	0	150	8	0	41	49	
Peak Factor	0.525								0.850				0.740				

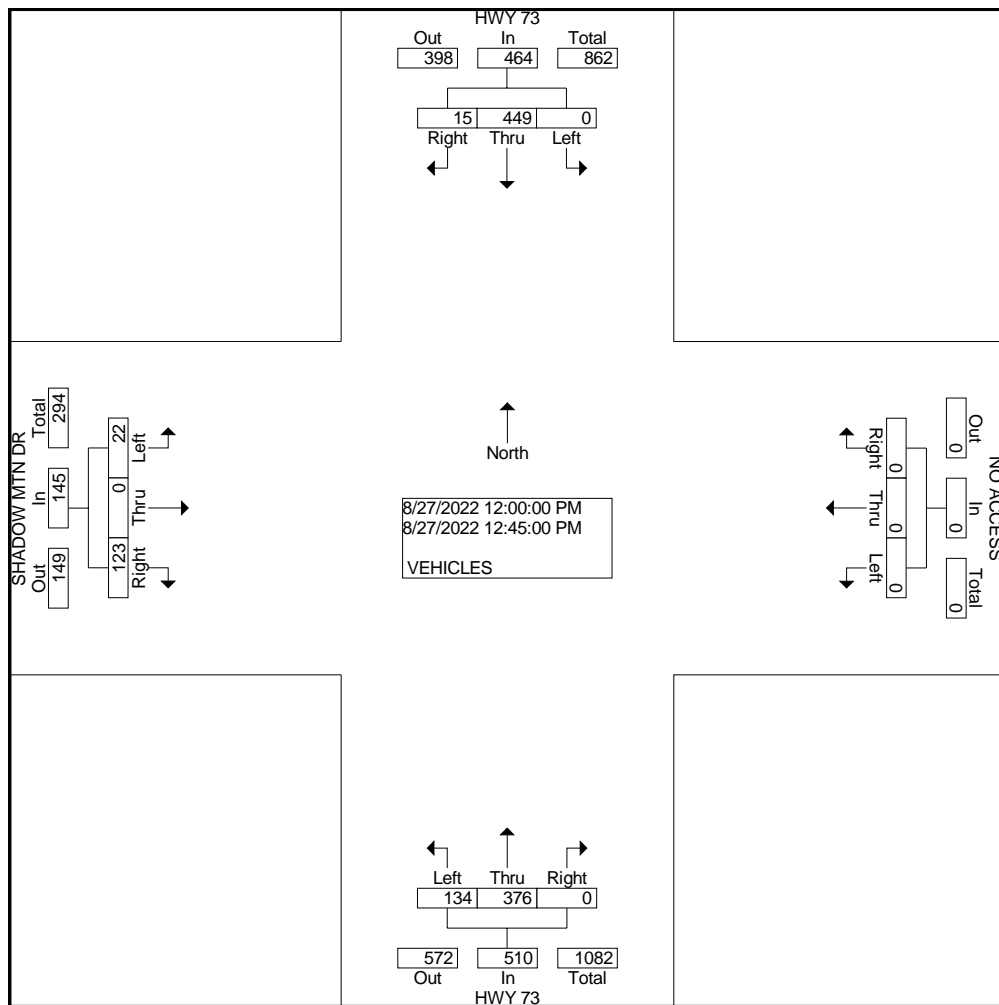

COUNTER MEASURES INC.

1889 YORK STREET
DENVER.COLORADO
303-333-7409

N/S STREET: HWY 73
E/W STREET: SHADOW MOUNTAIN DR
CITY: CONIFER
COUNTY: JEFFERSON

File Name : HWY73SHADOW0828
Site Code : 00000112
Start Date : 8/28/2022
Page No : 1

Groups Printed- VEHICLES

Start Time	HWY 73 Southbound			NO ACCESS Westbound			HWY 73 Northbound			SHADOW MTN DR Eastbound			Int. Total
	Left	Thru	Right	Left	Thru	Right	Left	Thru	Right	Left	Thru	Right	
Factor	1.0	1.0	1.0	1.0	1.0	1.0	1.0	1.0	1.0	1.0	1.0	1.0	
08:00 AM	0	34	0	0	0	0	10	33	0	1	0	16	94
08:15 AM	0	32	2	0	0	0	11	34	0	1	0	16	96
08:30 AM	0	44	2	0	0	0	10	44	0	1	0	15	116
08:45 AM	0	56	2	0	0	0	11	52	0	2	0	17	140
Total	0	166	6	0	0	0	42	163	0	5	0	64	446
09:00 AM	0	41	5	0	0	0	9	41	0	2	0	19	117
09:15 AM	0	68	2	0	0	0	23	53	0	5	0	28	179
09:30 AM	0	48	0	0	0	0	13	78	0	7	0	35	181
09:45 AM	0	61	4	0	0	0	15	81	0	10	0	30	201
Total	0	218	11	0	0	0	60	253	0	24	0	112	678
12:00 PM	0	83	3	0	0	0	18	88	0	2	0	23	217
12:15 PM	0	92	3	0	0	0	32	69	0	3	0	23	222
12:30 PM	0	71	1	0	1	0	32	85	0	1	0	27	218
12:45 PM	0	81	7	0	0	0	33	97	0	1	0	24	243
Total	0	327	14	0	1	0	115	339	0	7	0	97	900
01:00 PM	0	87	6	0	0	0	39	84	0	4	0	32	252
01:15 PM	0	76	4	0	0	0	27	88	0	6	0	25	226
01:30 PM	0	71	4	0	0	0	32	77	0	4	0	17	205
01:45 PM	0	74	6	0	0	0	26	72	0	5	0	21	204
Total	0	308	20	0	0	0	124	321	0	19	0	95	887
Grand Total	0	1019	51	0	1	0	341	1076	0	55	0	368	2911
Apprch %	0.0	95.2	4.8	0.0	100.0	0.0	24.1	75.9	0.0	13.0	0.0	87.0	
Total %	0.0	35.0	1.8	0.0	0.0	0.0	11.7	37.0	0.0	1.9	0.0	12.6	

COUNTER MEASURES INC.

1889 YORK STREET
DENVER, COLORADO
303-333-7409

N/S STREET: HWY 73
E/W STREET: SHADOW MOUNTAIN DR
CITY: CONIFER
COUNTY: JEFFERSON

File Name : HWY73SHADOW0828
Site Code : 00000112
Start Date : 8/28/2022
Page No : 2

Start Time	HWY 73 Southbound				NO ACCESS Westbound				HWY 73 Northbound				SHADOW MTN DR Eastbound				Int. Total
	Left	Thru	Right	App. Total	Left	Thru	Right	App. Total	Left	Thru	Right	App. Total	Left	Thru	Right	App. Total	
Peak Hour From 09:00 AM to 09:45 AM - Peak 1 of 1																	
Intersection	09:00 AM																
Volume	0	218	11	229	0	0	0	0	60	253	0	313	24	0	112	136	678
Percent	0.0	95.2	4.8		0.0	0.0	0.0		19.2	80.8	0.0		17.6	0.0	82.4		
09:45	09:45 AM																
Volume	0	61	4	65	0	0	0	0	15	81	0	96	10	0	30	40	201
Peak Factor	0.843																
High Int.	09:15 AM																
Volume	0	68	2	70	0	0	0	0	15	81	0	96	7	0	35	42	
Peak Factor	0.818								0.815				0.810				

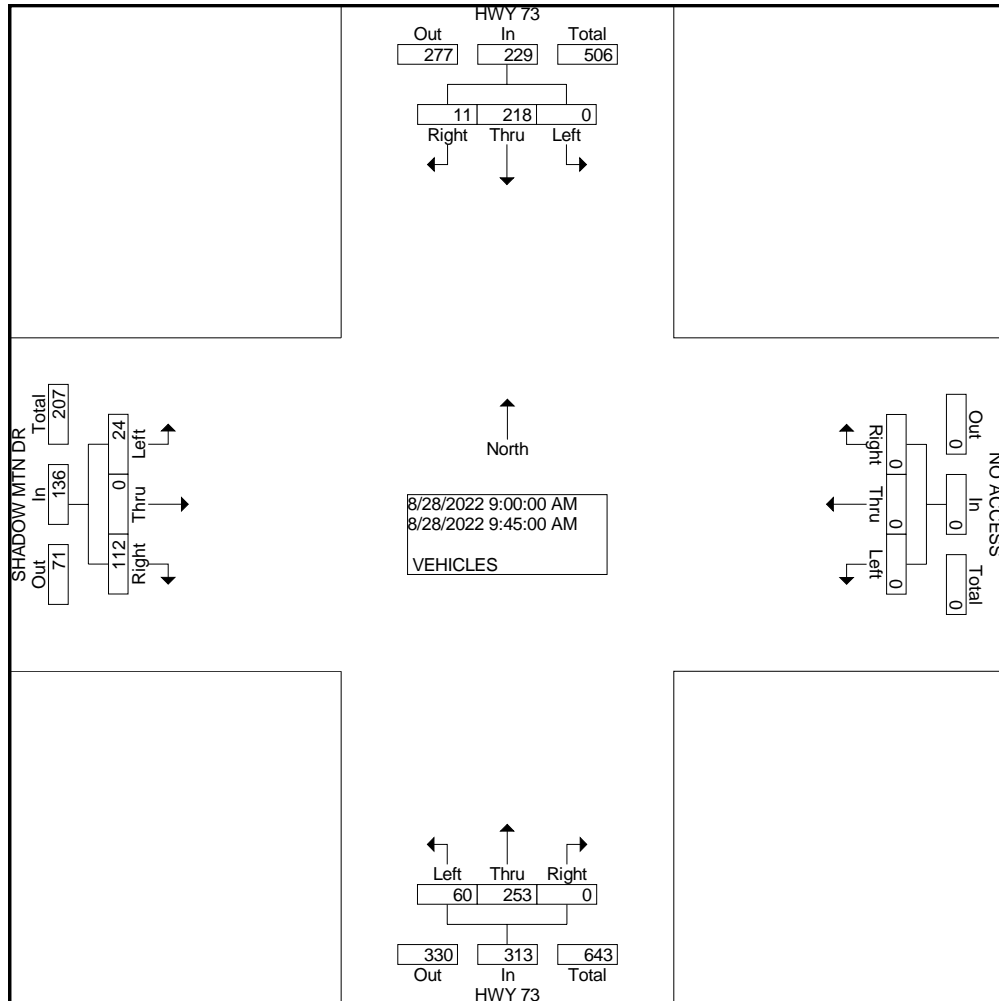

COUNTER MEASURES INC.

1889 YORK STREET
DENVER, COLORADO
303-333-7409

N/S STREET: HWY 73
E/W STREET: SHADOW MOUNTAIN DR
CITY: CONIFER
COUNTY: JEFFERSON

File Name : HWY73SHADOW0828
Site Code : 00000112
Start Date : 8/28/2022
Page No : 3

Start Time	HWY 73 Southbound				NO ACCESS Westbound				HWY 73 Northbound				SHADOW MTN DR Eastbound				Int. Total
	Left	Thru	Right	App. Total	Left	Thru	Right	App. Total	Left	Thru	Right	App. Total	Left	Thru	Right	App. Total	
Peak Hour From 12:30 PM to 01:15 PM - Peak 1 of 1																	
Intersection	12:30 PM																
Volume	0	315	18	333	0	1	0	1	131	354	0	485	12	0	108	120	939
Percent	0.0	94.6	5.4		0.0	100.0	0.0		27.0	73.0	0.0		10.0	0.0	90.0		
01:00 Volume	0	87	6	93	0	0	0	0	39	84	0	123	4	0	32	36	252
Peak Factor	0.932																
High Int.	01:00 PM				12:30 PM				12:45 PM				01:00 PM				
Volume	0	87	6	93	0	1	0	1	33	97	0	130	4	0	32	36	
Peak Factor	0.895				0.250				0.933				0.833				

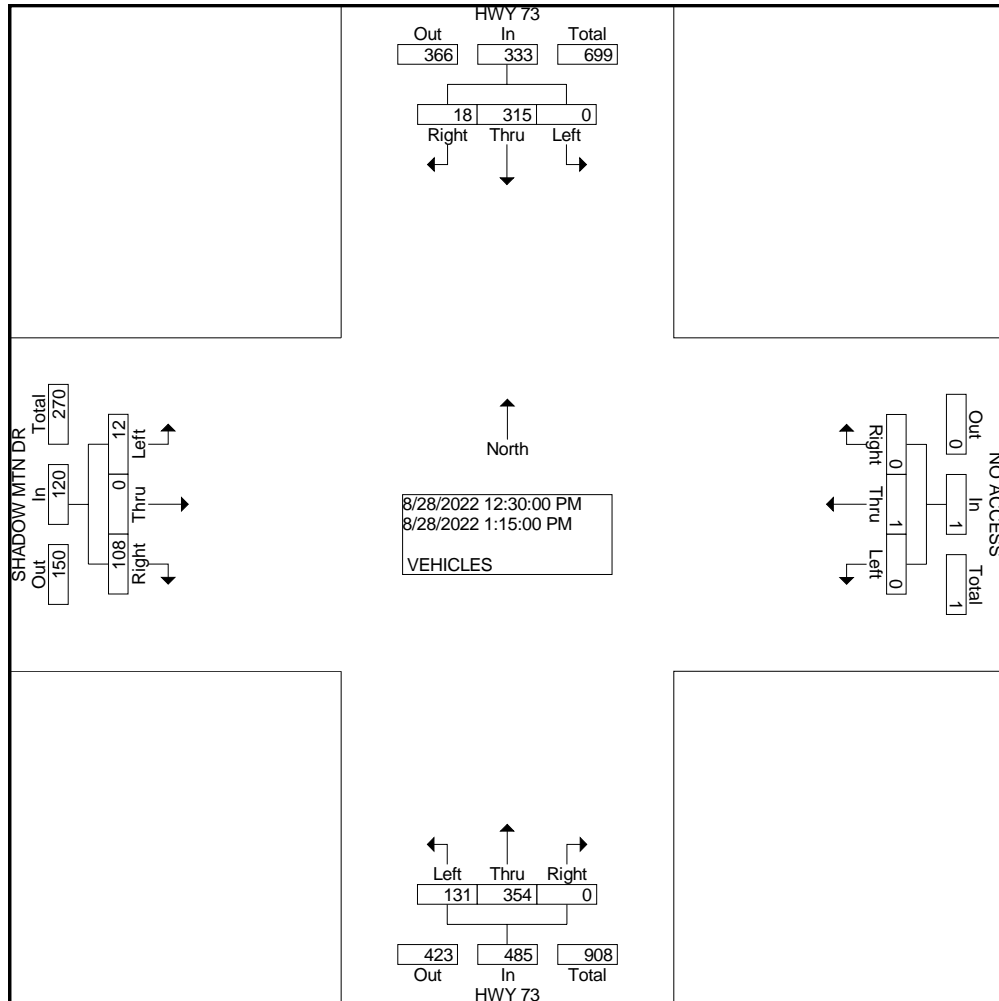

COUNTER MEASURES INC.
1889 YORK STREET
DENVER, COLORADO 80206
303-333-7409

Location: HWY 73 N-O BARKLEY RD
 City: CONIFER
 County: JEFFERSON
 Direction: NORTH/SOUTH

Site Code: 222208
 Station ID: 222208

Start Time	22-Aug-22 Mon	NORTH	SOUTH	Total
12:00 AM		*	*	*
01:00		*	*	*
02:00		*	*	*
03:00		*	*	*
04:00		*	*	*
05:00		*	*	*
06:00		*	*	*
07:00		*	*	*
08:00		*	*	*
09:00		*	*	*
10:00		*	*	*
11:00		*	*	*
12:00 PM		*	*	*
01:00		*	*	*
02:00		488	370	858
03:00		545	345	890
04:00		501	381	882
05:00		454	429	883
06:00		260	378	638
07:00		159	190	349
08:00		127	135	262
09:00		43	78	121
10:00		29	30	59
11:00		10	21	31
Total		2616	2357	4973
Percent		52.6%	47.4%	
AM Peak	-	-	-	-
Vol.	-	-	-	-
PM Peak	-	15:00	17:00	15:00
Vol.	-	545	429	890

COUNTER MEASURES INC.
1889 YORK STREET
DENVER, COLORADO 80206
303-333-7409

Location: HWY 73 N-O BARKLEY RD
 City: CONIFER
 County: JEFFERSON
 Direction: NORTH/SOUTH

Site Code: 222208
 Station ID: 222208

Start Time	23-Aug-22 Tue	NORTH	SOUTH							Total
12:00 AM		10	10							20
01:00		6	6							12
02:00		6	1							7
03:00		5	5							10
04:00		40	12							52
05:00		88	42							130
06:00		237	118							355
07:00		552	389							941
08:00		391	371							762
09:00		375	304							679
10:00		390	273							663
11:00		445	312							757
12:00 PM		441	278							719
01:00		503	244							747
02:00		547	298							845
03:00		599	356							955
04:00		581	359							940
05:00		549	424							973
06:00		365	335							700
07:00		244	239							483
08:00		148	206							354
09:00		73	97							170
10:00		15	51							66
11:00		16	36							52
Total		6626	4766							11392
Percent		58.2%	41.8%							
AM Peak	-	07:00	07:00	-	-	-	-	-	-	07:00
Vol.	-	552	389	-	-	-	-	-	-	941
PM Peak	-	15:00	17:00	-	-	-	-	-	-	17:00
Vol.	-	599	424	-	-	-	-	-	-	973

COUNTER MEASURES INC.
1889 YORK STREET
DENVER, COLORADO 80206
303-333-7409

Location: HWY 73 N-O BARKLEY RD
 City: CONIFER
 County: JEFFERSON
 Direction: NORTH/SOUTH

Site Code: 222208
 Station ID: 222208

Start Time	24-Aug-22 Wed	NORTH	SOUTH							Total
12:00 AM		9	12							21
01:00		5	6							11
02:00		2	6							8
03:00		6	10							16
04:00		30	15							45
05:00		94	43							137
06:00		227	139							366
07:00		489	356							845
08:00		453	398							851
09:00		407	317							724
10:00		400	224							624
11:00		461	275							736
12:00 PM		440	332							772
01:00		395	311							706
02:00		442	420							862
03:00		557	399							956
04:00		555	412							967
05:00		556	451							1007
06:00		314	341							655
07:00		176	271							447
08:00		147	175							322
09:00		87	101							188
10:00		28	49							77
11:00		15	20							35
Total		6295	5083							11378
Percent		55.3%	44.7%							
AM Peak	-	07:00	08:00	-	-	-	-	-	-	08:00
Vol.	-	489	398	-	-	-	-	-	-	851
PM Peak	-	15:00	17:00	-	-	-	-	-	-	17:00
Vol.	-	557	451	-	-	-	-	-	-	1007

COUNTER MEASURES INC.
1889 YORK STREET
DENVER, COLORADO 80206
303-333-7409

Location: HWY 73 N-O BARKLEY RD
 City: CONIFER
 County: JEFFERSON
 Direction: NORTH/SOUTH

Site Code: 222208
 Station ID: 222208

Start Time	25-Aug-22 Thu	NORTH	SOUTH							Total
12:00 AM		8	11							19
01:00		5	6							11
02:00		8	6							14
03:00		12	4							16
04:00		24	19							43
05:00		93	42							135
06:00		233	127							360
07:00		561	375							936
08:00		387	370							757
09:00		445	341							786
10:00		393	261							654
11:00		420	328							748
12:00 PM		452	367							819
01:00		397	338							735
02:00		429	425							854
03:00		532	446							978
04:00		421	431							852
05:00		449	475							924
06:00		278	300							578
07:00		186	223							409
08:00		126	144							270
09:00		68	94							162
10:00		36	46							82
11:00		18	46							64
Total		5981	5225							11206
Percent		53.4%	46.6%							
AM Peak	-	07:00	07:00	-	-	-	-	-	-	07:00
Vol.	-	561	375	-	-	-	-	-	-	936
PM Peak	-	15:00	17:00	-	-	-	-	-	-	15:00
Vol.	-	532	475	-	-	-	-	-	-	978

COUNTER MEASURES INC.
1889 YORK STREET
DENVER, COLORADO 80206
303-333-7409

Location: HWY 73 N-O BARKLEY RD
 City: CONIFER
 County: JEFFERSON
 Direction: NORTH/SOUTH

Site Code: 222208
 Station ID: 222208

Start Time	26-Aug-22 Fri	NORTH	SOUTH							Total
12:00 AM		5	21							26
01:00		7	2							9
02:00		7	11							18
03:00		7	6							13
04:00		35	15							50
05:00		87	37							124
06:00		214	126							340
07:00		495	333							828
08:00		398	323							721
09:00		378	395							773
10:00		437	326							763
11:00		484	338							822
12:00 PM		539	304							843
01:00		456	365							821
02:00		521	432							953
03:00		510	505							1015
04:00		457	389							846
05:00		438	407							845
06:00		287	310							597
07:00		205	242							447
08:00		114	153							267
09:00		78	110							188
10:00		47	54							101
11:00		28	31							59
Total		6234	5235							11469
Percent		54.4%	45.6%							
AM Peak	-	07:00	09:00	-	-	-	-	-	-	07:00
Vol.	-	495	395	-	-	-	-	-	-	828
PM Peak	-	12:00	15:00	-	-	-	-	-	-	15:00
Vol.	-	539	505	-	-	-	-	-	-	1015

COUNTER MEASURES INC.
1889 YORK STREET
DENVER, COLORADO 80206
303-333-7409

Location: HWY 73 N-O BARKLEY RD
 City: CONIFER
 County: JEFFERSON
 Direction: NORTH/SOUTH

Site Code: 222208
 Station ID: 222208

Start Time	27-Aug-22 Sat	NORTH	SOUTH							Total
12:00 AM		11	27							38
01:00		12	6							18
02:00		12	8							20
03:00		13	2							15
04:00		14	11							25
05:00		44	33							77
06:00		89	57							146
07:00		232	141							373
08:00		294	256							550
09:00		417	359							776
10:00		493	351							844
11:00		522	378							900
12:00 PM		503	457							960
01:00		545	458							1003
02:00		483	412							895
03:00		475	330							805
04:00		411	358							769
05:00		336	316							652
06:00		269	256							525
07:00		186	207							393
08:00		133	150							283
09:00		76	101							177
10:00		46	76							122
11:00		43	48							91
Total		5659	4798							10457
Percent		54.1%	45.9%							
AM Peak	-	11:00	11:00	-	-	-	-	-	-	11:00
Vol.	-	522	378	-	-	-	-	-	-	900
PM Peak	-	13:00	13:00	-	-	-	-	-	-	13:00
Vol.	-	545	458	-	-	-	-	-	-	1003

COUNTER MEASURES INC.
1889 YORK STREET
DENVER, COLORADO 80206
303-333-7409

Location: HWY 73 N-O BARKLEY RD
 City: CONIFER
 County: JEFFERSON
 Direction: NORTH/SOUTH

Site Code: 222208
 Station ID: 222208

Start Time	28-Aug-22 Sun	NORTH	SOUTH							Total
12:00 AM		22	30							52
01:00		18	4							22
02:00		11	5							16
03:00		7	3							10
04:00		10	13							23
05:00		27	16							43
06:00		62	40							102
07:00		139	113							252
08:00		238	199							437
09:00		335	312							647
10:00		418	346							764
11:00		481	360							841
12:00 PM		469	395							864
01:00		437	424							861
02:00		41	39							80
03:00		*	*							*
04:00		*	*							*
05:00		*	*							*
06:00		*	*							*
07:00		*	*							*
08:00		*	*							*
09:00		*	*							*
10:00		*	*							*
11:00		*	*							*
Total		2715	2299							5014
Percent		54.1%	45.9%							
AM Peak	-	11:00	11:00	-	-	-	-	-	-	11:00
Vol.	-	481	360	-	-	-	-	-	-	841
PM Peak	-	12:00	13:00	-	-	-	-	-	-	12:00
Vol.	-	469	424	-	-	-	-	-	-	864
Grand Total		36126	29763							65889
Percent		54.8%	45.2%							
ADT		ADT 9,827	AADT 9,827							

COUNTER MEASURES INC.
1889 YORK STREET
DENVER, COLORADO 80206
303-333-7409

Location: SHADOW MTN DR E-O S. WARHAWK RD 1
 City: CONIFER
 County: JEFFERSON
 Direction: EAST/WEST

Site Code: 22220
 Station ID: 22220

Start Time	22-Aug-22 Mon	EAST	WEST	Total
12:00 AM		*	*	*
01:00		*	*	*
02:00		*	*	*
03:00		*	*	*
04:00		*	*	*
05:00		*	*	*
06:00		*	*	*
07:00		*	*	*
08:00		*	*	*
09:00		*	*	*
10:00		*	*	*
11:00		*	*	*
12:00 PM		61	76	137
01:00		82	78	160
02:00		61	73	134
03:00		92	110	202
04:00		85	108	193
05:00		62	125	187
06:00		48	116	164
07:00		18	60	78
08:00		11	51	62
09:00		6	30	36
10:00		4	11	15
11:00		2	17	19
Total		532	855	1387
Percent		38.4%	61.6%	
AM Peak	-	-	-	-
Vol.	-	-	-	-
PM Peak	-	15:00	17:00	15:00
Vol.	-	92	125	202

COUNTER MEASURES INC.
1889 YORK STREET
DENVER, COLORADO 80206
303-333-7409

Location: SHADOW MTN DR E-O S. WARHAWK RD 1
 City: CONIFER
 County: JEFFERSON
 Direction: EAST/WEST

Site Code: 22220
 Station ID: 22220

Start Time	23-Aug-22 Tue	EAST	WEST							Total
12:00 AM		1	3							4
01:00		2	0							2
02:00		1	1							2
03:00		3	0							3
04:00		22	0							22
05:00		38	0							38
06:00		100	8							108
07:00		150	53							203
08:00		123	49							172
09:00		65	63							128
10:00		82	64							146
11:00		77	73							150
12:00 PM		84	79							163
01:00		70	72							142
02:00		79	86							165
03:00		97	104							201
04:00		78	113							191
05:00		82	132							214
06:00		43	110							153
07:00		25	69							94
08:00		20	54							74
09:00		4	30							34
10:00		2	23							25
11:00		4	15							19
Total		1252	1201							2453
Percent		51.0%	49.0%							
AM Peak	-	07:00	11:00	-	-	-	-	-	-	07:00
Vol.	-	150	73	-	-	-	-	-	-	203
PM Peak	-	15:00	17:00	-	-	-	-	-	-	17:00
Vol.	-	97	132	-	-	-	-	-	-	214

COUNTER MEASURES INC.
1889 YORK STREET
DENVER, COLORADO 80206
303-333-7409

Location: SHADOW MTN DR E-O S. WARHAWK RD 1
 City: CONIFER
 County: JEFFERSON
 Direction: EAST/WEST

Site Code: 22220
 Station ID: 22220

Start Time	24-Aug-22 Wed	EAST	WEST							Total
12:00 AM		1	8							9
01:00		2	1							3
02:00		0	2							2
03:00		3	1							4
04:00		21	1							22
05:00		38	2							40
06:00		79	15							94
07:00		151	55							206
08:00		133	59							192
09:00		80	67							147
10:00		77	43							120
11:00		92	65							157
12:00 PM		80	76							156
01:00		78	82							160
02:00		82	83							165
03:00		117	118							235
04:00		99	124							223
05:00		74	112							186
06:00		45	123							168
07:00		24	86							110
08:00		12	54							66
09:00		4	27							31
10:00		3	19							22
11:00		1	6							7
Total		1296	1229							2525
Percent		51.3%	48.7%							
AM Peak	-	07:00	09:00	-	-	-	-	-	-	07:00
Vol.	-	151	67	-	-	-	-	-	-	206
PM Peak	-	15:00	16:00	-	-	-	-	-	-	15:00
Vol.	-	117	124	-	-	-	-	-	-	235

COUNTER MEASURES INC.
1889 YORK STREET
DENVER, COLORADO 80206
303-333-7409

Location: SHADOW MTN DR E-O S. WARHAWK RD 1
 City: CONIFER
 County: JEFFERSON
 Direction: EAST/WEST

Site Code: 22220
 Station ID: 22220

Start Time	25-Aug-22 Thu	EAST	WEST							Total
12:00 AM		1	8							9
01:00		0	4							4
02:00		1	1							2
03:00		1	0							1
04:00		16	1							17
05:00		38	1							39
06:00		88	8							96
07:00		149	47							196
08:00		141	66							207
09:00		97	62							159
10:00		82	54							136
11:00		67	76							143
12:00 PM		71	86							157
01:00		84	72							156
02:00		89	62							151
03:00		74	108							182
04:00		90	114							204
05:00		57	136							193
06:00		38	88							126
07:00		17	64							81
08:00		12	53							65
09:00		8	33							41
10:00		4	18							22
11:00		1	15							16
Total		1226	1177							2403
Percent		51.0%	49.0%							
AM Peak	-	07:00	11:00	-	-	-	-	-	-	08:00
Vol.	-	149	76	-	-	-	-	-	-	207
PM Peak	-	16:00	17:00	-	-	-	-	-	-	16:00
Vol.	-	90	136	-	-	-	-	-	-	204

COUNTER MEASURES INC.
1889 YORK STREET
DENVER, COLORADO 80206
303-333-7409

Location: SHADOW MTN DR E-O S. WARHAWK RD 1
 City: CONIFER
 County: JEFFERSON
 Direction: EAST/WEST

Site Code: 22220
 Station ID: 22220

Start Time	26-Aug-22 Fri	EAST	WEST							Total
12:00 AM		0	7							7
01:00		2	2							4
02:00		2	1							3
03:00		1	2							3
04:00		19	0							19
05:00		35	1							36
06:00		68	9							77
07:00		130	45							175
08:00		114	42							156
09:00		89	61							150
10:00		90	69							159
11:00		88	69							157
12:00 PM		86	89							175
01:00		74	64							138
02:00		68	72							140
03:00		76	95							171
04:00		89	111							200
05:00		80	116							196
06:00		54	92							146
07:00		32	76							108
08:00		14	46							60
09:00		8	32							40
10:00		10	20							30
11:00		2	12							14
Total		1231	1133							2364
Percent		52.1%	47.9%							
AM Peak	-	07:00	10:00	-	-	-	-	-	-	07:00
Vol.	-	130	69	-	-	-	-	-	-	175
PM Peak	-	16:00	17:00	-	-	-	-	-	-	16:00
Vol.	-	89	116	-	-	-	-	-	-	200

COUNTER MEASURES INC.
1889 YORK STREET
DENVER, COLORADO 80206
303-333-7409

Location: SHADOW MTN DR E-O S. WARHAWK RD 1
 City: CONIFER
 County: JEFFERSON
 Direction: EAST/WEST

Site Code: 22220
 Station ID: 22220

Start Time	27-Aug-22 Sat	EAST	WEST							Total
12:00 AM		3	10							13
01:00		0	5							5
02:00		4	3							7
03:00		4	0							4
04:00		10	0							10
05:00		9	1							10
06:00		37	9							46
07:00		70	19							89
08:00		88	48							136
09:00		89	62							151
10:00		119	84							203
11:00		105	80							185
12:00 PM		104	99							203
01:00		100	105							205
02:00		80	104							184
03:00		92	104							196
04:00		76	77							153
05:00		73	68							141
06:00		51	66							117
07:00		53	54							107
08:00		27	43							70
09:00		10	29							39
10:00		9	18							27
11:00		3	20							23
Total		1216	1108							2324
Percent		52.3%	47.7%							
AM Peak	-	10:00	10:00	-	-	-	-	-	-	10:00
Vol.	-	119	84	-	-	-	-	-	-	203
PM Peak	-	12:00	13:00	-	-	-	-	-	-	13:00
Vol.	-	104	105	-	-	-	-	-	-	205

COUNTER MEASURES INC.
1889 YORK STREET
DENVER, COLORADO 80206
303-333-7409

Location: SHADOW MTN DR E-O S. WARHAWK RD 1
 City: CONIFER
 County: JEFFERSON
 Direction: EAST/WEST

Site Code: 22220
 Station ID: 22220

Start Time	28-Aug-22 Sun	EAST	WEST	Total						
12:00 AM		1	10	11						
01:00		3	4	7						
02:00		0	1	1						
03:00		1	1	2						
04:00		5	2	7						
05:00		11	1	12						
06:00		17	6	23						
07:00		46	17	63						
08:00		57	34	91						
09:00		107	49	156						
10:00		84	72	156						
11:00		96	88	184						
12:00 PM		100	76	176						
01:00		91	101	192						
02:00		52	41	93						
03:00		*	*	*						
04:00		*	*	*						
05:00		*	*	*						
06:00		*	*	*						
07:00		*	*	*						
08:00		*	*	*						
09:00		*	*	*						
10:00		*	*	*						
11:00		*	*	*						
Total		671	503	1174						
Percent		57.2%	42.8%							
AM Peak	-	09:00	11:00	-	-	-	-	-	-	11:00
Vol.	-	107	88	-	-	-	-	-	-	184
PM Peak	-	12:00	13:00	-	-	-	-	-	-	13:00
Vol.	-	100	101	-	-	-	-	-	-	192
Grand Total		7424	7206							14630
Percent		50.7%	49.3%							
ADT		ADT 2,137	AADT 2,137							

COUNTER MEASURES INC.
1889 YORK STREET
DENVER, COLORADO 80206
303-333-7409

Location: SHADOW MTN DR E-O SHADOW BROOK DR
 City: CONIFER
 County: JEFFERSON
 Direction: EAST/WEST

Site Code: 222214
 Station ID: 222214

Start Time	22-Aug-22 Mon	EAST	WEST	Total
12:00 AM		*	*	*
01:00		*	*	*
02:00		*	*	*
03:00		*	*	*
04:00		*	*	*
05:00		*	*	*
06:00		*	*	*
07:00		*	*	*
08:00		*	*	*
09:00		*	*	*
10:00		*	*	*
11:00		*	*	*
12:00 PM		*	*	*
01:00		92	93	185
02:00		74	77	151
03:00		105	120	225
04:00		91	113	204
05:00		82	122	204
06:00		57	129	186
07:00		22	71	93
08:00		18	51	69
09:00		18	25	43
10:00		5	11	16
11:00		2	16	18
Total		566	828	1394
Percent		40.6%	59.4%	
AM Peak	-	-	-	-
Vol.	-	-	-	-
PM Peak	-	15:00	18:00	15:00
Vol.	-	105	129	225

COUNTER MEASURES INC.
1889 YORK STREET
DENVER, COLORADO 80206
303-333-7409

Location: SHADOW MTN DR E-O SHADOW BROOK DR
 City: CONIFER
 County: JEFFERSON
 Direction: EAST/WEST

Site Code: 222214
 Station ID: 222214

Start Time	23-Aug-22 Tue	EAST	WEST							Total
12:00 AM		1	3							4
01:00		2	0							2
02:00		1	1							2
03:00		2	0							2
04:00		22	0							22
05:00		42	0							42
06:00		106	10							116
07:00		164	53							217
08:00		140	53							193
09:00		72	65							137
10:00		90	68							158
11:00		90	73							163
12:00 PM		87	86							173
01:00		76	78							154
02:00		82	88							170
03:00		111	118							229
04:00		95	120							215
05:00		94	143							237
06:00		43	120							163
07:00		35	74							109
08:00		20	66							86
09:00		6	38							44
10:00		3	19							22
11:00		4	14							18
Total		1388	1290							2678
Percent		51.8%	48.2%							
AM Peak	-	07:00	11:00	-	-	-	-	-	-	07:00
Vol.	-	164	73	-	-	-	-	-	-	217
PM Peak	-	15:00	17:00	-	-	-	-	-	-	17:00
Vol.	-	111	143	-	-	-	-	-	-	237

COUNTER MEASURES INC.
1889 YORK STREET
DENVER, COLORADO 80206
303-333-7409

Location: SHADOW MTN DR E-O SHADOW BROOK DR
 City: CONIFER
 County: JEFFERSON
 Direction: EAST/WEST

Site Code: 222214
 Station ID: 222214

Start Time	24-Aug-22 Wed	EAST	WEST							Total
12:00 AM		8	3							11
01:00		2	1							3
02:00		0	2							2
03:00		3	1							4
04:00		18	0							18
05:00		45	2							47
06:00		85	17							102
07:00		158	55							213
08:00		148	65							213
09:00		82	68							150
10:00		86	48							134
11:00		93	77							170
12:00 PM		87	83							170
01:00		84	93							177
02:00		87	101							188
03:00		121	129							250
04:00		90	154							244
05:00		85	123							208
06:00		60	124							184
07:00		25	100							125
08:00		19	49							68
09:00		7	33							40
10:00		4	20							24
11:00		1	6							7
Total		1398	1354							2752
Percent		50.8%	49.2%							
AM Peak	-	07:00	11:00	-	-	-	-	-	-	07:00
Vol.	-	158	77	-	-	-	-	-	-	213
PM Peak	-	15:00	16:00	-	-	-	-	-	-	15:00
Vol.	-	121	154	-	-	-	-	-	-	250

COUNTER MEASURES INC.
1889 YORK STREET
DENVER, COLORADO 80206
303-333-7409

Location: SHADOW MTN DR E-O SHADOW BROOK DR
 City: CONIFER
 County: JEFFERSON
 Direction: EAST/WEST

Site Code: 222214
 Station ID: 222214

Start Time	25-Aug-22 Thu	EAST	WEST							Total
12:00 AM		3	8							11
01:00		0	4							4
02:00		1	1							2
03:00		2	1							3
04:00		16	0							16
05:00		39	2							41
06:00		88	12							100
07:00		161	54							215
08:00		162	68							230
09:00		103	71							174
10:00		85	57							142
11:00		74	83							157
12:00 PM		83	89							172
01:00		88	81							169
02:00		95	75							170
03:00		89	125							214
04:00		90	131							221
05:00		60	150							210
06:00		49	97							146
07:00		23	71							94
08:00		19	57							76
09:00		9	35							44
10:00		8	16							24
11:00		16	3							19
Total		1363	1291							2654
Percent		51.4%	48.6%							
AM Peak	-	08:00	11:00	-	-	-	-	-	-	08:00
Vol.	-	162	83	-	-	-	-	-	-	230
PM Peak	-	14:00	17:00	-	-	-	-	-	-	16:00
Vol.	-	95	150	-	-	-	-	-	-	221

COUNTER MEASURES INC.
1889 YORK STREET
DENVER, COLORADO 80206
303-333-7409

Location: SHADOW MTN DR E-O SHADOW BROOK DR
 City: CONIFER
 County: JEFFERSON
 Direction: EAST/WEST

Site Code: 222214
 Station ID: 222214

Start Time	26-Aug-22 Fri	EAST	WEST							Total
12:00 AM		0	7							7
01:00		2	2							4
02:00		2	2							4
03:00		1	2							3
04:00		19	0							19
05:00		39	1							40
06:00		72	9							81
07:00		138	47							185
08:00		135	48							183
09:00		100	66							166
10:00		106	76							182
11:00		87	82							169
12:00 PM		91	96							187
01:00		85	74							159
02:00		78	82							160
03:00		90	109							199
04:00		90	128							218
05:00		76	141							217
06:00		53	101							154
07:00		45	82							127
08:00		14	46							60
09:00		9	39							48
10:00		17	19							36
11:00		4	15							19
Total		1353	1274							2627
Percent		51.5%	48.5%							
AM Peak	-	07:00	11:00	-	-	-	-	-	-	07:00
Vol.	-	138	82	-	-	-	-	-	-	185
PM Peak	-	12:00	17:00	-	-	-	-	-	-	16:00
Vol.	-	91	141	-	-	-	-	-	-	218

COUNTER MEASURES INC.
1889 YORK STREET
DENVER, COLORADO 80206
303-333-7409

Location: SHADOW MTN DR E-O SHADOW BROOK DR
 City: CONIFER
 County: JEFFERSON
 Direction: EAST/WEST

Site Code: 222214
 Station ID: 222214

Start Time	27-Aug-22 Sat	EAST	WEST							Total
12:00 AM		2	10							12
01:00		9	0							9
02:00		8	0							8
03:00		4	0							4
04:00		10	0							10
05:00		10	1							11
06:00		39	9							48
07:00		71	21							92
08:00		92	54							146
09:00		101	65							166
10:00		132	90							222
11:00		111	93							204
12:00 PM		103	120							223
01:00		99	127							226
02:00		86	116							202
03:00		95	117							212
04:00		81	91							172
05:00		80	77							157
06:00		57	81							138
07:00		50	58							108
08:00		27	50							77
09:00		7	37							44
10:00		10	22							32
11:00		13	13							26
Total		1297	1252							2549
Percent		50.9%	49.1%							
AM Peak	-	10:00	11:00	-	-	-	-	-	-	10:00
Vol.	-	132	93	-	-	-	-	-	-	222
PM Peak	-	12:00	13:00	-	-	-	-	-	-	13:00
Vol.	-	103	127	-	-	-	-	-	-	226

COUNTER MEASURES INC.
1889 YORK STREET
DENVER, COLORADO 80206
303-333-7409

Location: SHADOW MTN DR E-O SHADOW BROOK DR
 City: CONIFER
 County: JEFFERSON
 Direction: EAST/WEST

Site Code: 222214
 Station ID: 222214

Start Time	28-Aug-22 Sun	EAST	WEST	Total						
12:00 AM		2	9	11						
01:00		3	4	7						
02:00		1	2	3						
03:00		1	1	2						
04:00		3	3	6						
05:00		15	1	16						
06:00		20	5	25						
07:00		46	17	63						
08:00		61	39	100						
09:00		113	56	169						
10:00		100	80	180						
11:00		109	89	198						
12:00 PM		92	104	196						
01:00		88	114	202						
02:00		38	37	75						
03:00		*	*	*						
04:00		*	*	*						
05:00		*	*	*						
06:00		*	*	*						
07:00		*	*	*						
08:00		*	*	*						
09:00		*	*	*						
10:00		*	*	*						
11:00		*	*	*						
Total		692	561	1253						
Percent		55.2%	44.8%							
AM Peak	-	09:00	11:00	-	-	-	-	-	-	11:00
Vol.	-	113	89	-	-	-	-	-	-	198
PM Peak	-	12:00	13:00	-	-	-	-	-	-	13:00
Vol.	-	92	114	-	-	-	-	-	-	202
Grand Total		8057	7850							15907
Percent		50.7%	49.3%							
ADT		ADT 2,351	AADT 2,351							

COUNTER MEASURES INC.
1889 YORK STREET
DENVER, COLORADO 80206
303-333-7409

Location: SHADOW MTN DR W-O CONIFER DR
 City: CONIFER
 County: JEFFERSON
 Direction: EAST/WEST

Site Code: 222218
 Station ID: 222218

Start Time	22-Aug-22 Mon	EAST	WEST	Total
12:00 AM		*	*	*
01:00		*	*	*
02:00		*	*	*
03:00		*	*	*
04:00		*	*	*
05:00		*	*	*
06:00		*	*	*
07:00		*	*	*
08:00		*	*	*
09:00		*	*	*
10:00		*	*	*
11:00		*	*	*
12:00 PM		*	*	*
01:00		84	138	222
02:00		95	100	195
03:00		129	138	267
04:00		109	152	261
05:00		122	130	252
06:00		142	86	228
07:00		78	32	110
08:00		65	18	83
09:00		38	7	45
10:00		13	7	20
11:00		17	2	19
Total		892	810	1702
Percent		52.4%	47.6%	
AM Peak	-	-	-	-
Vol.	-	-	-	-
PM Peak	-	18:00	16:00	-
Vol.	-	142	152	-

COUNTER MEASURES INC.
1889 YORK STREET
DENVER, COLORADO 80206
303-333-7409

Location: SHADOW MTN DR W-O CONIFER DR
 City: CONIFER
 County: JEFFERSON
 Direction: EAST/WEST

Site Code: 222218
 Station ID: 222218

Start Time	23-Aug-22 Tue	EAST	WEST							Total
12:00 AM		4	2							6
01:00		0	4							4
02:00		1	1							2
03:00		0	4							4
04:00		1	23							24
05:00		1	51							52
06:00		14	120							134
07:00		58	189							247
08:00		55	167							222
09:00		77	96							173
10:00		74	97							171
11:00		104	91							195
12:00 PM		100	103							203
01:00		104	72							176
02:00		117	87							204
03:00		158	104							262
04:00		147	110							257
05:00		169	118							287
06:00		123	92							215
07:00		92	36							128
08:00		81	22							103
09:00		34	17							51
10:00		24	3							27
11:00		18	4							22
Total		1556	1613							3169
Percent		49.1%	50.9%							
AM Peak	-	11:00	07:00	-	-	-	-	-	-	07:00
Vol.	-	104	189	-	-	-	-	-	-	247
PM Peak	-	17:00	17:00	-	-	-	-	-	-	17:00
Vol.	-	169	118	-	-	-	-	-	-	287

COUNTER MEASURES INC.
1889 YORK STREET
DENVER, COLORADO 80206
303-333-7409

Location: SHADOW MTN DR W-O CONIFER DR
 City: CONIFER
 County: JEFFERSON
 Direction: EAST/WEST

Site Code: 222218
 Station ID: 222218

Start Time	24-Aug-22 Wed	EAST	WEST							Total
12:00 AM		7	5							12
01:00		1	3							4
02:00		2	0							2
03:00		1	4							5
04:00		0	20							20
05:00		3	52							55
06:00		21	99							120
07:00		61	183							244
08:00		70	180							250
09:00		76	104							180
10:00		57	101							158
11:00		94	95							189
12:00 PM		98	92							190
01:00		111	88							199
02:00		125	92							217
03:00		163	132							295
04:00		173	106							279
05:00		146	122							268
06:00		145	79							224
07:00		106	42							148
08:00		64	19							83
09:00		35	8							43
10:00		25	3							28
11:00		7	1							8
Total		1591	1630							3221
Percent		49.4%	50.6%							
AM Peak	-	11:00	07:00	-	-	-	-	-	-	08:00
Vol.	-	94	183	-	-	-	-	-	-	250
PM Peak	-	16:00	15:00	-	-	-	-	-	-	15:00
Vol.	-	173	132	-	-	-	-	-	-	295

COUNTER MEASURES INC.
1889 YORK STREET
DENVER, COLORADO 80206
303-333-7409

Location: SHADOW MTN DR W-O CONIFER DR
 City: CONIFER
 County: JEFFERSON
 Direction: EAST/WEST

Site Code: 222218
 Station ID: 222218

Start Time	25-Aug-22 Thu	EAST	WEST							Total
12:00 AM		10	1							11
01:00		4	0							4
02:00		1	2							3
03:00		2	4							6
04:00		0	17							17
05:00		3	48							51
06:00		11	98							109
07:00		53	192							245
08:00		79	180							259
09:00		71	148							219
10:00		66	98							164
11:00		99	86							185
12:00 PM		112	91							203
01:00		89	111							200
02:00		86	106							192
03:00		138	115							253
04:00		151	103							254
05:00		168	90							258
06:00		117	56							173
07:00		92	30							122
08:00		73	18							91
09:00		41	13							54
10:00		24	4							28
11:00		19	1							20
Total		1509	1612							3121
Percent		48.3%	51.7%							
AM Peak	-	11:00	07:00	-	-	-	-	-	-	08:00
Vol.	-	99	192	-	-	-	-	-	-	259
PM Peak	-	17:00	15:00	-	-	-	-	-	-	17:00
Vol.	-	168	115	-	-	-	-	-	-	258

COUNTER MEASURES INC.
1889 YORK STREET
DENVER, COLORADO 80206
303-333-7409

Location: SHADOW MTN DR W-O CONIFER DR
 City: CONIFER
 County: JEFFERSON
 Direction: EAST/WEST

Site Code: 222218
 Station ID: 222218

Start Time	26-Aug-22 Fri	EAST	WEST							Total
12:00 AM		8	0							8
01:00		2	2							4
02:00		3	3							6
03:00		0	4							4
04:00		0	21							21
05:00		2	45							47
06:00		7	84							91
07:00		52	166							218
08:00		58	165							223
09:00		85	107							192
10:00		85	144							229
11:00		102	100							202
12:00 PM		121	99							220
01:00		91	89							180
02:00		94	113							207
03:00		120	131							251
04:00		150	99							249
05:00		161	97							258
06:00		111	62							173
07:00		102	48							150
08:00		54	19							73
09:00		46	10							56
10:00		29	13							42
11:00		17	4							21
Total		1500	1625							3125
Percent		48.0%	52.0%							
AM Peak	-	11:00	07:00	-	-	-	-	-	-	10:00
Vol.	-	102	166	-	-	-	-	-	-	229
PM Peak	-	17:00	15:00	-	-	-	-	-	-	17:00
Vol.	-	161	131	-	-	-	-	-	-	258

COUNTER MEASURES INC.
1889 YORK STREET
DENVER, COLORADO 80206
303-333-7409

Location: SHADOW MTN DR W-O CONIFER DR
 City: CONIFER
 County: JEFFERSON
 Direction: EAST/WEST

Site Code: 222218
 Station ID: 222218

Start Time	27-Aug-22 Sat	EAST	WEST							Total
12:00 AM		14	2							16
01:00		7	1							8
02:00		3	5							8
03:00		0	5							5
04:00		0	10							10
05:00		2	10							12
06:00		10	40							50
07:00		22	82							104
08:00		58	115							173
09:00		74	132							206
10:00		111	135							246
11:00		111	124							235
12:00 PM		140	120							260
01:00		153	108							261
02:00		144	91							235
03:00		145	94							239
04:00		105	90							195
05:00		80	118							198
06:00		93	80							173
07:00		70	56							126
08:00		63	28							91
09:00		43	10							53
10:00		25	12							37
11:00		12	16							28
Total		1485	1484							2969
Percent		50.0%	50.0%							
AM Peak	-	10:00	10:00	-	-	-	-	-	-	10:00
Vol.	-	111	135	-	-	-	-	-	-	246
PM Peak	-	13:00	12:00	-	-	-	-	-	-	13:00
Vol.	-	153	120	-	-	-	-	-	-	261

COUNTER MEASURES INC.
1889 YORK STREET
DENVER, COLORADO 80206
303-333-7409

Location: SHADOW MTN DR W-O CONIFER DR
 City: CONIFER
 County: JEFFERSON
 Direction: EAST/WEST

Site Code: 222218
 Station ID: 222218

Start Time	28-Aug-22 Sun	EAST	WEST							Total
12:00 AM		12	3							15
01:00		4	4							8
02:00		2	1							3
03:00		1	2							3
04:00		3	4							7
05:00		2	15							17
06:00		6	21							27
07:00		20	54							74
08:00		39	65							104
09:00		61	138							199
10:00		105	109							214
11:00		118	117							235
12:00 PM		123	101							224
01:00		98	156							254
02:00		68	78							146
03:00		1	0							1
04:00		0	0							0
05:00		*	*							*
06:00		*	*							*
07:00		*	*							*
08:00		*	*							*
09:00		*	*							*
10:00		*	*							*
11:00		*	*							*
Total		663	868							1531
Percent		43.3%	56.7%							
AM Peak	-	11:00	09:00	-	-	-	-	-	-	11:00
Vol.	-	118	138	-	-	-	-	-	-	235
PM Peak	-	12:00	13:00	-	-	-	-	-	-	13:00
Vol.	-	123	156	-	-	-	-	-	-	254
Grand Total		9196	9642							18838
Percent		48.8%	51.2%							
ADT		ADT 2,776	AADT 2,776							

COUNTER MEASURES INC.
1889 YORK STREET
DENVER, COLORADO 80206
303-333-7409

Location: SHADOW MTN DR W-O HWY 73
 City: CONIFER
 County: JEFFERSON
 Direction: EAST/WEST

Site Code: 222207
 Station ID: 222207

Start Time	22-Aug-22 Mon	EAST	WEST	Total
12:00 AM		*	*	*
01:00		*	*	*
02:00		*	*	*
03:00		*	*	*
04:00		*	*	*
05:00		*	*	*
06:00		*	*	*
07:00		*	*	*
08:00		*	*	*
09:00		*	*	*
10:00		*	*	*
11:00		*	*	*
12:00 PM		*	*	*
01:00		99	102	201
02:00		90	99	189
03:00		110	155	265
04:00		100	145	245
05:00		79	162	241
06:00		60	156	216
07:00		29	84	113
08:00		18	61	79
09:00		7	38	45
10:00		7	14	21
11:00		2	16	18
Total		601	1032	1633
Percent		36.8%	63.2%	
AM Peak	-	-	-	-
Vol.	-	-	-	-
PM Peak	-	15:00	17:00	15:00
Vol.	-	110	162	265

COUNTER MEASURES INC.
1889 YORK STREET
DENVER, COLORADO 80206
303-333-7409

Location: SHADOW MTN DR W-O HWY 73
 City: CONIFER
 County: JEFFERSON
 Direction: EAST/WEST

Site Code: 222207
 Station ID: 222207

Start Time	23-Aug-22 Tue	EAST	WEST							Total
12:00 AM		2	4							6
01:00		4	0							4
02:00		1	1							2
03:00		4	0							4
04:00		23	1							24
05:00		51	1							52
06:00		122	16							138
07:00		185	66							251
08:00		169	63							232
09:00		84	78							162
10:00		93	82							175
11:00		102	92							194
12:00 PM		158	60							218
01:00		184	0							184
02:00		207	0							207
03:00		270	0							270
04:00		266	0							266
05:00		290	0							290
06:00		217	0							217
07:00		125	0							125
08:00		105	0							105
09:00		52	0							52
10:00		27	0							27
11:00		21	0							21
Total		2762	464							3226
Percent		85.6%	14.4%							
AM Peak	-	07:00	11:00	-	-	-	-	-	-	07:00
Vol.	-	185	92	-	-	-	-	-	-	251
PM Peak	-	17:00	12:00	-	-	-	-	-	-	17:00
Vol.	-	290	60	-	-	-	-	-	-	290

COUNTER MEASURES INC.
1889 YORK STREET
DENVER, COLORADO 80206
303-333-7409

Location: SHADOW MTN DR W-O HWY 73
 City: CONIFER
 County: JEFFERSON
 Direction: EAST/WEST

Site Code: 222207
 Station ID: 222207

Start Time	24-Aug-22 Wed	EAST	WEST	Total					
12:00 AM		12	0	12					
01:00		4	0	4					
02:00		3	0	3					
03:00		5	0	5					
04:00		20	0	20					
05:00		55	0	55					
06:00		121	0	121					
07:00		253	0	253					
08:00		260	0	260					
09:00		180	0	180					
10:00		157	0	157					
11:00		196	0	196					
12:00 PM		191	0	191					
01:00		144	69	213					
02:00		105	119	224					
03:00		134	162	296					
04:00		119	178	297					
05:00		96	170	266					
06:00		64	171	235					
07:00		33	106	139					
08:00		17	64	81					
09:00		8	33	41					
10:00		3	25	28					
11:00		1	7	8					
Total		2181	1104	3285					
Percent		66.4%	33.6%						
AM Peak	-	08:00	-	-	-	-	-	-	08:00
Vol.	-	260	-	-	-	-	-	-	260
PM Peak	-	12:00	16:00	-	-	-	-	-	16:00
Vol.	-	191	178	-	-	-	-	-	297

COUNTER MEASURES INC.
1889 YORK STREET
DENVER, COLORADO 80206
303-333-7409

Location: SHADOW MTN DR W-O HWY 73
 City: CONIFER
 County: JEFFERSON
 Direction: EAST/WEST

Site Code: 222207
 Station ID: 222207

Start Time	25-Aug-22 Thu	EAST	WEST							Total
12:00 AM		1	11							12
01:00		0	3							3
02:00		2	1							3
03:00		4	2							6
04:00		17	0							17
05:00		48	3							51
06:00		100	11							111
07:00		180	67							247
08:00		180	85							265
09:00		124	80							204
10:00		98	65							163
11:00		95	98							193
12:00 PM		94	115							209
01:00		96	96							192
02:00		108	94							202
03:00		113	144							257
04:00		103	158							261
05:00		80	180							260
06:00		60	122							182
07:00		30	95							125
08:00		16	76							92
09:00		12	41							53
10:00		4	24							28
11:00		1	20							21
Total		1566	1591							3157
Percent		49.6%	50.4%							
AM Peak	-	07:00	11:00	-	-	-	-	-	-	08:00
Vol.	-	180	98	-	-	-	-	-	-	265
PM Peak	-	15:00	17:00	-	-	-	-	-	-	16:00
Vol.	-	113	180	-	-	-	-	-	-	261

COUNTER MEASURES INC.
1889 YORK STREET
DENVER, COLORADO 80206
303-333-7409

Location: SHADOW MTN DR W-O HWY 73
 City: CONIFER
 County: JEFFERSON
 Direction: EAST/WEST

Site Code: 222207
 Station ID: 222207

Start Time	26-Aug-22 Fri	EAST	WEST							Total
12:00 AM		0	7							7
01:00		2	3							5
02:00		3	2							5
03:00		2	2							4
04:00		22	0							22
05:00		45	3							48
06:00		87	7							94
07:00		166	59							225
08:00		168	63							231
09:00		102	84							186
10:00		130	88							218
11:00		107	104							211
12:00 PM		102	123							225
01:00		92	95							187
02:00		101	109							210
03:00		118	122							240
04:00		96	167							263
05:00		95	151							246
06:00		63	116							179
07:00		49	108							157
08:00		21	55							76
09:00		10	48							58
10:00		12	28							40
11:00		6	18							24
Total		1599	1562							3161
Percent		50.6%	49.4%							
AM Peak	-	08:00	11:00	-	-	-	-	-	-	08:00
Vol.	-	168	104	-	-	-	-	-	-	231
PM Peak	-	15:00	16:00	-	-	-	-	-	-	16:00
Vol.	-	118	167	-	-	-	-	-	-	263

COUNTER MEASURES INC.
1889 YORK STREET
DENVER, COLORADO 80206
303-333-7409

Location: SHADOW MTN DR W-O HWY 73
 City: CONIFER
 County: JEFFERSON
 Direction: EAST/WEST

Site Code: 222207
 Station ID: 222207

Start Time	27-Aug-22 Sat	EAST	WEST							Total
12:00 AM		2	15							17
01:00		1	7							8
02:00		5	3							8
03:00		5	0							5
04:00		10	0							10
05:00		10	2							12
06:00		40	11							51
07:00		82	23							105
08:00		116	60							176
09:00		126	81							207
10:00		151	108							259
11:00		135	102							237
12:00 PM		128	142							270
01:00		115	146							261
02:00		99	146							245
03:00		108	141							249
04:00		95	107							202
05:00		95	101							196
06:00		65	93							158
07:00		54	69							123
08:00		28	62							90
09:00		8	44							52
10:00		8	26							34
11:00		7	23							30
Total		1493	1512							3005
Percent		49.7%	50.3%							
AM Peak	-	10:00	10:00	-	-	-	-	-	-	10:00
Vol.	-	151	108	-	-	-	-	-	-	259
PM Peak	-	12:00	13:00	-	-	-	-	-	-	12:00
Vol.	-	128	146	-	-	-	-	-	-	270

COUNTER MEASURES INC.
1889 YORK STREET
DENVER, COLORADO 80206
303-333-7409

Location: SHADOW MTN DR W-O HWY 73
 City: CONIFER
 County: JEFFERSON
 Direction: EAST/WEST

Site Code: 222207
 Station ID: 222207

Start Time	28-Aug-22 Sun	EAST	WEST							Total
12:00 AM		3	13							16
01:00		4	3							7
02:00		1	2							3
03:00		3	1							4
04:00		4	3							7
05:00		15	4							19
06:00		22	7							29
07:00		56	21							77
08:00		67	43							110
09:00		131	61							192
10:00		127	99							226
11:00		132	107							239
12:00 PM		102	126							228
01:00		105	136							241
02:00		26	30							56
03:00		*	*							*
04:00		*	*							*
05:00		*	*							*
06:00		*	*							*
07:00		*	*							*
08:00		*	*							*
09:00		*	*							*
10:00		*	*							*
11:00		*	*							*
Total		798	656							1454
Percent		54.9%	45.1%							
AM Peak	-	11:00	11:00	-	-	-	-	-	-	11:00
Vol.	-	132	107	-	-	-	-	-	-	239
PM Peak	-	13:00	13:00	-	-	-	-	-	-	13:00
Vol.	-	105	136	-	-	-	-	-	-	241
Grand Total		11000	7921							18921
Percent		58.1%	41.9%							
ADT		ADT 2,782	AADT 2,782							

LEVEL OF SERVICE DEFINITIONS

From *Highway Capacity Manual*, Transportation Research Board, 2016, 6th Edition

UNSIGNALIZED INTERSECTION LEVEL OF SERVICE (LOS)

Applicable to Two-Way Stop Control, All-Way Stop Control, and Roundabouts

LOS	Average Vehicle Control Delay	<u>Operational Characteristics</u>
A	<10 seconds	Normally, vehicles on the stop-controlled approach only have to wait up to 10 seconds before being able to clear the intersection. Left-turning vehicles on the uncontrolled street do not have to wait to make their turn.
B	10 to 15 seconds	Vehicles on the stop-controlled approach will experience delays before being able to clear the intersection. <u>The delay could be up to 15 seconds.</u> Left-turning vehicles on the uncontrolled street may have to wait to make their turn.
C	15 to 25 seconds	Vehicles on the stop-controlled approach can expect delays in the range of 15 to 25 seconds before clearing the intersection. Motorists may begin to take chances due to the long delays, thereby posing a safety risk to through traffic. <u>Left-turning vehicles on the uncontrolled street will now be required to wait to make their turn causing a queue to be created in the turn lane.</u>
D	25 to 35 seconds	<u>This is the point at which a traffic signal may be warranted for this intersection.</u> The delays for the stop-controlled intersection are not considered to be excessive. The length of the queue may begin to block other public and private access points.
E	35 to 50 seconds	The delays for all critical traffic movements are considered to be unacceptable. The length of the queues for the stop-controlled approaches as well as the left-turn movements are extremely long. <u>There is a high probability that this intersection will meet traffic signal warrants.</u> The ability to install a traffic signal is affected by the location of other existing traffic signals. Consideration may be given to restricting the accesses by eliminating the left-turn movements from and to the stop-controlled approach.
F	>50 seconds	The delay for the critical traffic movements are probably in excess of 100 seconds. The length of the queues are extremely long. Motorists are selecting alternative routes due to the long delays. <u>The only remedy for these long delays is installing a traffic signal or restricting the accesses.</u> The potential for accidents at this intersection are extremely high due to motorist taking more risky chances. If the median permits, motorists begin making two-stage left-turns.

Intersection						
Int Delay, s/veh	3					
Movement	SET	SER	NWL	NWT	NEL	NER
Lane Configurations	↑	↗	↖	↑	↖	↗
Traffic Vol, veh/h	433	16	183	310	8	100
Future Vol, veh/h	433	16	183	310	8	100
Conflicting Peds, #/hr	0	0	0	0	0	0
Sign Control	Free	Free	Free	Free	Stop	Stop
RT Channelized	-	None	-	None	-	None
Storage Length	-	245	485	-	105	0
Veh in Median Storage, #	0	-	-	0	0	-
Grade, %	0	-	-	0	0	-
Peak Hour Factor	88	88	88	88	88	88
Heavy Vehicles, %	2	2	2	2	2	2
Mvmt Flow	492	18	208	352	9	114

Major/Minor	Major1	Major2	Minor1	Minor2	Minor3
Conflicting Flow All	0	0	510	0	1260
Stage 1	-	-	-	-	492
Stage 2	-	-	-	-	768
Critical Hdwy	-	-	4.12	-	6.42
Critical Hdwy Stg 1	-	-	-	-	5.42
Critical Hdwy Stg 2	-	-	-	-	5.42
Follow-up Hdwy	-	-	2.218	-	3.518
Pot Cap-1 Maneuver	-	-	1055	-	188
Stage 1	-	-	-	-	615
Stage 2	-	-	-	-	458
Platoon blocked, %	-	-	-	-	-
Mov Cap-1 Maneuver	-	-	1055	-	151
Mov Cap-2 Maneuver	-	-	-	-	151
Stage 1	-	-	-	-	615
Stage 2	-	-	-	-	368

Approach	SE	NW	NE
HCM Control Delay, s	0	3.4	14.1
HCM LOS			B

Minor Lane/Major Mvmt	NELn1	NELn2	NWL	NWT	SET	SER
Capacity (veh/h)	151	577	1055	-	-	-
HCM Lane V/C Ratio	0.06	0.197	0.197	-	-	-
HCM Control Delay (s)	30.4	12.8	9.2	-	-	-
HCM Lane LOS	D	B	A	-	-	-
HCM 95th %tile Q(veh)	0.2	0.7	0.7	-	-	-

Intersection

Int Delay, s/veh 12

Movement	SEL	SET	NWT	NWR	SWL	SWR
Lane Configurations	↘	↗	↗	↘	↘	↘
Traffic Vol, veh/h	274	276	177	78	114	315
Future Vol, veh/h	274	276	177	78	114	315
Conflicting Peds, #/hr	0	0	0	0	0	0
Sign Control	Free	Free	Free	Free	Stop	Stop
RT Channelized	-	None	-	None	-	None
Storage Length	325	-	-	270	150	0
Veh in Median Storage, #	-	0	0	-	0	-
Grade, %	-	0	0	-	0	-
Peak Hour Factor	88	88	88	88	88	88
Heavy Vehicles, %	2	2	2	2	2	2
Mvmt Flow	311	314	201	89	130	358

Major/Minor	Major1	Major2	Minor2
Conflicting Flow All	290	0	0
Stage 1	-	-	201
Stage 2	-	-	936
Critical Hdwy	4.12	-	6.42
Critical Hdwy Stg 1	-	-	5.42
Critical Hdwy Stg 2	-	-	5.42
Follow-up Hdwy	2.218	-	3.518
Pot Cap-1 Maneuver	1272	-	223
Stage 1	-	-	833
Stage 2	-	-	382
Platoon blocked, %	-	-	-
Mov Cap-1 Maneuver	1272	-	169
Mov Cap-2 Maneuver	-	-	169
Stage 1	-	-	630
Stage 2	-	-	382

Approach	SE	NW	SW
HCM Control Delay, s	4.4	0	28.8
HCM LOS			D

Minor Lane/Major Mvmt	NWT	NWR	SEL	SETSWLn1SWLn2
Capacity (veh/h)	-	-	1272	169 840
HCM Lane V/C Ratio	-	-	0.245	0.767 0.426
HCM Control Delay (s)	-	-	8.7	74.3 12.4
HCM Lane LOS	-	-	A	F B
HCM 95th %tile Q(veh)	-	-	1	4.9 2.2

Intersection						
Int Delay, s/veh	2.9					
Movement	SET	SER	NWL	NWT	NEL	NER
Lane Configurations	↑	↗	↖	↑	↖	↗
Traffic Vol, veh/h	269	9	87	294	12	120
Future Vol, veh/h	269	9	87	294	12	120
Conflicting Peds, #/hr	0	0	0	0	0	0
Sign Control	Free	Free	Free	Free	Stop	Stop
RT Channelized	-	None	-	None	-	None
Storage Length	-	245	485	-	105	0
Veh in Median Storage, #	0	-	-	0	0	-
Grade, %	0	-	-	0	0	-
Peak Hour Factor	88	88	88	88	88	88
Heavy Vehicles, %	2	2	2	2	2	2
Mvmt Flow	306	10	99	334	14	136

Major/Minor	Major1	Major2	Minor1			
Conflicting Flow All	0	0	316	0	838	306
Stage 1	-	-	-	-	306	-
Stage 2	-	-	-	-	532	-
Critical Hdwy	-	-	4.12	-	6.42	6.22
Critical Hdwy Stg 1	-	-	-	-	5.42	-
Critical Hdwy Stg 2	-	-	-	-	5.42	-
Follow-up Hdwy	-	-	2.218	-	3.518	3.318
Pot Cap-1 Maneuver	-	-	1244	-	336	734
Stage 1	-	-	-	-	747	-
Stage 2	-	-	-	-	589	-
Platoon blocked, %	-	-	-	-	-	-
Mov Cap-1 Maneuver	-	-	1244	-	309	734
Mov Cap-2 Maneuver	-	-	-	-	309	-
Stage 1	-	-	-	-	747	-
Stage 2	-	-	-	-	542	-

Approach	SE	NW	NE
HCM Control Delay, s	0	1.9	11.6
HCM LOS			B

Minor Lane/Major Mvmt	NELn1	NELn2	NWL	NWT	SET	SER
Capacity (veh/h)	309	734	1244	-	-	-
HCM Lane V/C Ratio	0.044	0.186	0.079	-	-	-
HCM Control Delay (s)	17.2	11	8.1	-	-	-
HCM Lane LOS	C	B	A	-	-	-
HCM 95th %tile Q(veh)	0.1	0.7	0.3	-	-	-

Intersection

Int Delay, s/veh 8.4

Movement SEL SET NWT NWR SWL SWR

Lane Configurations	↘	↗	↗	↘	↘	↘
Traffic Vol, veh/h	223	178	182	27	109	193
Future Vol, veh/h	223	178	182	27	109	193
Conflicting Peds, #/hr	0	0	0	0	0	0
Sign Control	Free	Free	Free	Free	Stop	Stop
RT Channelized	-	None	-	None	-	None
Storage Length	325	-	-	270	150	0
Veh in Median Storage, #	-	0	0	-	0	-
Grade, %	-	0	0	-	0	-
Peak Hour Factor	88	88	88	88	88	88
Heavy Vehicles, %	2	2	2	2	2	2
Mvmt Flow	253	202	207	31	124	219

Major/Minor Major1 Major2 Minor2

Conflicting Flow All	238	0	-	0	915	207
Stage 1	-	-	-	-	207	-
Stage 2	-	-	-	-	708	-
Critical Hdwy	4.12	-	-	-	6.42	6.22
Critical Hdwy Stg 1	-	-	-	-	5.42	-
Critical Hdwy Stg 2	-	-	-	-	5.42	-
Follow-up Hdwy	2.218	-	-	-	3.518	3.318
Pot Cap-1 Maneuver	1329	-	-	-	303	833
Stage 1	-	-	-	-	828	-
Stage 2	-	-	-	-	488	-
Platoon blocked, %	-	-	-	-	-	-
Mov Cap-1 Maneuver	1329	-	-	-	245	833
Mov Cap-2 Maneuver	-	-	-	-	245	-
Stage 1	-	-	-	-	671	-
Stage 2	-	-	-	-	488	-

Approach SE NW SW

HCM Control Delay, s	4.6	0	19.2
HCM LOS			C

Minor Lane/Major Mvmt NWT NWR SEL SETSWLn1SWLn2

Capacity (veh/h)	-	-	1329	-	245	833
HCM Lane V/C Ratio	-	-	0.191	-	0.506	0.263
HCM Control Delay (s)	-	-	8.3	-	33.8	10.9
HCM Lane LOS	-	-	A	-	D	B
HCM 95th %tile Q(veh)	-	-	0.7	-	2.6	1.1

Intersection						
Int Delay, s/veh	3.2					
Movement	SET	SER	NWL	NWT	NEL	NER
Lane Configurations	↑	↗	↘	↑	↘	↗
Traffic Vol, veh/h	449	15	134	376	22	123
Future Vol, veh/h	449	15	134	376	22	123
Conflicting Peds, #/hr	0	0	0	0	0	0
Sign Control	Free	Free	Free	Free	Stop	Stop
RT Channelized	-	None	-	None	-	None
Storage Length	-	245	485	-	105	0
Veh in Median Storage, #	0	-	-	0	0	-
Grade, %	0	-	-	0	0	-
Peak Hour Factor	88	88	88	88	88	88
Heavy Vehicles, %	2	2	2	2	2	2
Mvmt Flow	510	17	152	427	25	140

Major/Minor	Major1	Major2	Minor1	Minor2	Minor3
Conflicting Flow All	0	0	527	0	1241
Stage 1	-	-	-	-	510
Stage 2	-	-	-	-	731
Critical Hdwy	-	-	4.12	-	6.42
Critical Hdwy Stg 1	-	-	-	-	5.42
Critical Hdwy Stg 2	-	-	-	-	5.42
Follow-up Hdwy	-	-	2.218	-	3.518
Pot Cap-1 Maneuver	-	-	1040	-	193
Stage 1	-	-	-	-	603
Stage 2	-	-	-	-	476
Platoon blocked, %	-	-	-	-	-
Mov Cap-1 Maneuver	-	-	1040	-	165
Mov Cap-2 Maneuver	-	-	-	-	165
Stage 1	-	-	-	-	603
Stage 2	-	-	-	-	407

Approach	SE	NW	NE
HCM Control Delay, s	0	2.4	16.1
HCM LOS			C

Minor Lane/Major Mvmt	NELn1	NELn2	NWL	NWT	SET	SER
Capacity (veh/h)	165	563	1040	-	-	-
HCM Lane V/C Ratio	0.152	0.248	0.146	-	-	-
HCM Control Delay (s)	30.7	13.5	9.1	-	-	-
HCM Lane LOS	D	B	A	-	-	-
HCM 95th %tile Q(veh)	0.5	1	0.5	-	-	-

Intersection

Int Delay, s/veh 14.7

Movement SEL SET NWT NWR SWL SWR

Lane Configurations	↘	↗	↗	↘	↘	↘
Traffic Vol, veh/h	467	188	231	88	58	271
Future Vol, veh/h	467	188	231	88	58	271
Conflicting Peds, #/hr	0	0	0	0	0	0
Sign Control	Free	Free	Free	Free	Stop	Stop
RT Channelized	-	None	-	None	-	None
Storage Length	325	-	-	270	150	0
Veh in Median Storage, #	-	0	0	-	0	-
Grade, %	-	0	0	-	0	-
Peak Hour Factor	88	88	88	88	88	88
Heavy Vehicles, %	2	2	2	2	2	2
Mvmt Flow	531	214	263	100	66	308

Major/Minor Major1 Major2 Minor2

Conflicting Flow All	363	0	-	0	1539	263
Stage 1	-	-	-	-	263	-
Stage 2	-	-	-	-	1276	-
Critical Hdwy	4.12	-	-	-	6.42	6.22
Critical Hdwy Stg 1	-	-	-	-	5.42	-
Critical Hdwy Stg 2	-	-	-	-	5.42	-
Follow-up Hdwy	2.218	-	-	-	3.518	3.318
Pot Cap-1 Maneuver	1196	-	-	-	127	776
Stage 1	-	-	-	-	781	-
Stage 2	-	-	-	-	262	-
Platoon blocked, %	-	-	-	-	-	-
Mov Cap-1 Maneuver	1196	-	-	-	71	776
Mov Cap-2 Maneuver	-	-	-	-	71	-
Stage 1	-	-	-	-	434	-
Stage 2	-	-	-	-	262	-

Approach SE NW SW

HCM Control Delay, s	7.4	0	43.3
HCM LOS			E

Minor Lane/Major Mvmt NWT NWR SEL SETSWLn1SWLn2

Capacity (veh/h)	-	-	1196	-	71	776
HCM Lane V/C Ratio	-	-	0.444	-	0.928	0.397
HCM Control Delay (s)	-	-	10.4	-	186	12.7
HCM Lane LOS	-	-	B	-	F	B
HCM 95th %tile Q(veh)	-	-	2.3	-	4.7	1.9

Intersection						
Int Delay, s/veh	2.9					
Movement	SET	SER	NWL	NWT	NEL	NER
Lane Configurations	↑	↗	↘	↑	↘	↗
Traffic Vol, veh/h	218	11	60	253	24	112
Future Vol, veh/h	218	11	60	253	24	112
Conflicting Peds, #/hr	0	0	0	0	0	0
Sign Control	Free	Free	Free	Free	Stop	Stop
RT Channelized	-	None	-	None	-	None
Storage Length	-	245	485	-	105	0
Veh in Median Storage, #	0	-	-	0	0	-
Grade, %	0	-	-	0	0	-
Peak Hour Factor	88	88	88	88	88	88
Heavy Vehicles, %	2	2	2	2	2	2
Mvmt Flow	248	13	68	288	27	127

Major/Minor	Major1	Major2	Minor1			
Conflicting Flow All	0	0	261	0	672	248
Stage 1	-	-	-	-	248	-
Stage 2	-	-	-	-	424	-
Critical Hdwy	-	-	4.12	-	6.42	6.22
Critical Hdwy Stg 1	-	-	-	-	5.42	-
Critical Hdwy Stg 2	-	-	-	-	5.42	-
Follow-up Hdwy	-	-	2.218	-	3.518	3.318
Pot Cap-1 Maneuver	-	-	1303	-	421	791
Stage 1	-	-	-	-	793	-
Stage 2	-	-	-	-	660	-
Platoon blocked, %	-	-	-	-	-	-
Mov Cap-1 Maneuver	-	-	1303	-	399	791
Mov Cap-2 Maneuver	-	-	-	-	399	-
Stage 1	-	-	-	-	793	-
Stage 2	-	-	-	-	626	-

Approach	SE	NW	NE
HCM Control Delay, s	0	1.5	11.2
HCM LOS			B

Minor Lane/Major Mvmt	NELn1	NELn2	NWL	NWT	SET	SER
Capacity (veh/h)	399	791	1303	-	-	-
HCM Lane V/C Ratio	0.068	0.161	0.052	-	-	-
HCM Control Delay (s)	14.7	10.4	7.9	-	-	-
HCM Lane LOS	B	B	A	-	-	-
HCM 95th %tile Q(veh)	0.2	0.6	0.2	-	-	-

Intersection

Int Delay, s/veh 4.9

Movement SEL SET NWT NWR SWL SWR

Lane Configurations	↘	↗	↗	↘	↘	↗
Traffic Vol, veh/h	208	115	187	18	12	137
Future Vol, veh/h	208	115	187	18	12	137
Conflicting Peds, #/hr	0	0	0	0	0	0
Sign Control	Free	Free	Free	Free	Stop	Stop
RT Channelized	-	None	-	None	-	None
Storage Length	325	-	-	270	150	0
Veh in Median Storage, #	-	0	0	-	0	-
Grade, %	-	0	0	-	0	-
Peak Hour Factor	88	88	88	88	88	88
Heavy Vehicles, %	2	2	2	2	2	2
Mvmt Flow	236	131	213	20	14	156

Major/Minor Major1 Major2 Minor2

Conflicting Flow All	233	0	-	0	816	213
Stage 1	-	-	-	-	213	-
Stage 2	-	-	-	-	603	-
Critical Hdwy	4.12	-	-	-	6.42	6.22
Critical Hdwy Stg 1	-	-	-	-	5.42	-
Critical Hdwy Stg 2	-	-	-	-	5.42	-
Follow-up Hdwy	2.218	-	-	-	3.518	3.318
Pot Cap-1 Maneuver	1335	-	-	-	347	827
Stage 1	-	-	-	-	823	-
Stage 2	-	-	-	-	546	-
Platoon blocked, %	-	-	-	-	-	-
Mov Cap-1 Maneuver	1335	-	-	-	286	827
Mov Cap-2 Maneuver	-	-	-	-	286	-
Stage 1	-	-	-	-	677	-
Stage 2	-	-	-	-	546	-

Approach SE NW SW

HCM Control Delay, s	5.3	0	11
HCM LOS			B

Minor Lane/Major Mvmt NWT NWR SEL SETSWLn1SWLn2

Capacity (veh/h)	-	-	1335	-	286	827
HCM Lane V/C Ratio	-	-	0.177	-	0.048	0.188
HCM Control Delay (s)	-	-	8.3	-	18.2	10.4
HCM Lane LOS	-	-	A	-	C	B
HCM 95th %tile Q(veh)	-	-	0.6	-	0.1	0.7

Intersection						
Int Delay, s/veh	2.8					
Movement	SET	SER	NWL	NWT	NEL	NER
Lane Configurations	↑	↗	↖	↑	↖	↗
Traffic Vol, veh/h	315	18	131	354	12	108
Future Vol, veh/h	315	18	131	354	12	108
Conflicting Peds, #/hr	0	0	0	0	0	0
Sign Control	Free	Free	Free	Free	Stop	Stop
RT Channelized	-	None	-	None	-	None
Storage Length	-	245	485	-	105	0
Veh in Median Storage, #	0	-	-	0	0	-
Grade, %	0	-	-	0	0	-
Peak Hour Factor	88	88	88	88	88	88
Heavy Vehicles, %	2	2	2	2	2	2
Mvmt Flow	358	20	149	402	14	123

Major/Minor	Major1	Major2	Minor1			
Conflicting Flow All	0	0	378	0	1058	358
Stage 1	-	-	-	-	358	-
Stage 2	-	-	-	-	700	-
Critical Hdwy	-	-	4.12	-	6.42	6.22
Critical Hdwy Stg 1	-	-	-	-	5.42	-
Critical Hdwy Stg 2	-	-	-	-	5.42	-
Follow-up Hdwy	-	-	2.218	-	3.518	3.318
Pot Cap-1 Maneuver	-	-	1180	-	249	686
Stage 1	-	-	-	-	707	-
Stage 2	-	-	-	-	493	-
Platoon blocked, %	-	-	-	-	-	-
Mov Cap-1 Maneuver	-	-	1180	-	218	686
Mov Cap-2 Maneuver	-	-	-	-	218	-
Stage 1	-	-	-	-	707	-
Stage 2	-	-	-	-	431	-

Approach	SE	NW	NE
HCM Control Delay, s	0	2.3	12.5
HCM LOS			B

Minor Lane/Major Mvmt	NELn1	NELn2	NWL	NWT	SET	SER
Capacity (veh/h)	218	686	1180	-	-	-
HCM Lane V/C Ratio	0.063	0.179	0.126	-	-	-
HCM Control Delay (s)	22.6	11.4	8.5	-	-	-
HCM Lane LOS	C	B	A	-	-	-
HCM 95th %tile Q(veh)	0.2	0.6	0.4	-	-	-

Intersection						
Int Delay, s/veh	5.9					
Movement	SEL	SET	NWT	NWR	SWL	SWR
Lane Configurations	↘	↗	↗	↘	↘	↘
Traffic Vol, veh/h	242	193	235	49	24	248
Future Vol, veh/h	242	193	235	49	24	248
Conflicting Peds, #/hr	0	0	0	0	0	0
Sign Control	Free	Free	Free	Free	Stop	Stop
RT Channelized	-	None	-	None	-	None
Storage Length	325	-	-	270	150	0
Veh in Median Storage, #	-	0	0	-	0	-
Grade, %	-	0	0	-	0	-
Peak Hour Factor	88	88	88	88	88	88
Heavy Vehicles, %	2	2	2	2	2	2
Mvmt Flow	275	219	267	56	27	282
Major/Minor	Major1	Major2	Minor2			
Conflicting Flow All	323	0	-	0	1036	267
Stage 1	-	-	-	-	267	-
Stage 2	-	-	-	-	769	-
Critical Hdwy	4.12	-	-	-	6.42	6.22
Critical Hdwy Stg 1	-	-	-	-	5.42	-
Critical Hdwy Stg 2	-	-	-	-	5.42	-
Follow-up Hdwy	2.218	-	-	-	3.518	3.318
Pot Cap-1 Maneuver	1237	-	-	-	256	772
Stage 1	-	-	-	-	778	-
Stage 2	-	-	-	-	457	-
Platoon blocked, %	-	-	-	-	-	-
Mov Cap-1 Maneuver	1237	-	-	-	199	772
Mov Cap-2 Maneuver	-	-	-	-	199	-
Stage 1	-	-	-	-	605	-
Stage 2	-	-	-	-	457	-
Approach	SE	NW	SW			
HCM Control Delay, s	4.9	0	13.5			
HCM LOS			B			
Minor Lane/Major Mvmt	NWT	NWR	SEL	SET	SWLn1	SWLn2
Capacity (veh/h)	-	-	1237	-	199	772
HCM Lane V/C Ratio	-	-	0.222	-	0.137	0.365
HCM Control Delay (s)	-	-	8.7	-	25.9	12.3
HCM Lane LOS	-	-	A	-	D	B
HCM 95th %tile Q(veh)	-	-	0.9	-	0.5	1.7

Intersection						
Int Delay, s/veh	3.1					
Movement	SET	SER	NWL	NWT	NEL	NER
Lane Configurations	↑	↗	↖	↑	↖	↗
Traffic Vol, veh/h	445	16	186	320	8	102
Future Vol, veh/h	445	16	186	320	8	102
Conflicting Peds, #/hr	0	0	0	0	0	0
Sign Control	Free	Free	Free	Free	Stop	Stop
RT Channelized	-	None	-	None	-	None
Storage Length	-	245	485	-	105	0
Veh in Median Storage, #	0	-	-	0	0	-
Grade, %	0	-	-	0	0	-
Peak Hour Factor	88	88	88	88	88	88
Heavy Vehicles, %	2	2	2	2	2	2
Mvmt Flow	506	18	211	364	9	116

Major/Minor	Major1	Major2	Minor1		
Conflicting Flow All	0	0	524	0	1292
Stage 1	-	-	-	-	506
Stage 2	-	-	-	-	786
Critical Hdwy	-	-	4.12	-	6.42
Critical Hdwy Stg 1	-	-	-	-	5.42
Critical Hdwy Stg 2	-	-	-	-	5.42
Follow-up Hdwy	-	-	2.218	-	3.518
Pot Cap-1 Maneuver	-	-	1043	-	180
Stage 1	-	-	-	-	606
Stage 2	-	-	-	-	449
Platoon blocked, %	-	-	-	-	-
Mov Cap-1 Maneuver	-	-	1043	-	144
Mov Cap-2 Maneuver	-	-	-	-	144
Stage 1	-	-	-	-	606
Stage 2	-	-	-	-	358

Approach	SE	NW	NE
HCM Control Delay, s	0	3.4	14.4
HCM LOS			B

Minor Lane/Major Mvmt	NELn1	NELn2	NWL	NWT	SET	SER
Capacity (veh/h)	144	566	1043	-	-	-
HCM Lane V/C Ratio	0.063	0.205	0.203	-	-	-
HCM Control Delay (s)	31.7	13	9.3	-	-	-
HCM Lane LOS	D	B	A	-	-	-
HCM 95th %tile Q(veh)	0.2	0.8	0.8	-	-	-

Intersection						
Int Delay, s/veh	13.2					
Movement	SEL	SET	NWT	NWR	SWL	SWR
Lane Configurations	↘	↗	↗	↘	↘	↘
Traffic Vol, veh/h	280	280	180	80	117	325
Future Vol, veh/h	280	280	180	80	117	325
Conflicting Peds, #/hr	0	0	0	0	0	0
Sign Control	Free	Free	Free	Free	Stop	Stop
RT Channelized	-	None	-	None	-	None
Storage Length	325	-	-	270	150	0
Veh in Median Storage, #	-	0	0	-	0	-
Grade, %	-	0	0	-	0	-
Peak Hour Factor	88	88	88	88	88	88
Heavy Vehicles, %	2	2	2	2	2	2
Mvmt Flow	318	318	205	91	133	369

Major/Minor	Major1	Major2	Minor2		
Conflicting Flow All	296	0	-	0	1159 205
Stage 1	-	-	-	-	205 -
Stage 2	-	-	-	-	954 -
Critical Hdwy	4.12	-	-	-	6.42 6.22
Critical Hdwy Stg 1	-	-	-	-	5.42 -
Critical Hdwy Stg 2	-	-	-	-	5.42 -
Follow-up Hdwy	2.218	-	-	-	3.518 3.318
Pot Cap-1 Maneuver	1265	-	-	-	216 836
Stage 1	-	-	-	-	829 -
Stage 2	-	-	-	-	374 -
Platoon blocked, %	-	-	-	-	-
Mov Cap-1 Maneuver	1265	-	-	-	162 836
Mov Cap-2 Maneuver	-	-	-	-	162 -
Stage 1	-	-	-	-	621 -
Stage 2	-	-	-	-	374 -

Approach	SE	NW	SW
HCM Control Delay, s	4.4	0	32.1
HCM LOS			D

Minor Lane/Major Mvmt	NWT	NWR	SEL	SETSWLn1SWLn2		
Capacity (veh/h)	-	-	1265	-	162	836
HCM Lane V/C Ratio	-	-	0.252	-	0.821	0.442
HCM Control Delay (s)	-	-	8.8	-	86.1	12.7
HCM Lane LOS	-	-	A	-	F	B
HCM 95th %tile Q(veh)	-	-	1	-	5.5	2.3

Intersection						
Int Delay, s/veh	2.8					
Movement	SET	SER	NWL	NWT	NEL	NER
Lane Configurations	↑	↗	↘	↑	↘	↗
Traffic Vol, veh/h	277	9	88	303	12	122
Future Vol, veh/h	277	9	88	303	12	122
Conflicting Peds, #/hr	0	0	0	0	0	0
Sign Control	Free	Free	Free	Free	Stop	Stop
RT Channelized	-	None	-	None	-	None
Storage Length	-	245	485	-	105	0
Veh in Median Storage, #	0	-	-	0	0	-
Grade, %	0	-	-	0	0	-
Peak Hour Factor	88	88	88	88	88	88
Heavy Vehicles, %	2	2	2	2	2	2
Mvmt Flow	315	10	100	344	14	139

Major/Minor	Major1	Major2	Minor1			
Conflicting Flow All	0	0	325	0	859	315
Stage 1	-	-	-	-	315	-
Stage 2	-	-	-	-	544	-
Critical Hdwy	-	-	4.12	-	6.42	6.22
Critical Hdwy Stg 1	-	-	-	-	5.42	-
Critical Hdwy Stg 2	-	-	-	-	5.42	-
Follow-up Hdwy	-	-	2.218	-	3.518	3.318
Pot Cap-1 Maneuver	-	-	1235	-	327	725
Stage 1	-	-	-	-	740	-
Stage 2	-	-	-	-	582	-
Platoon blocked, %	-	-	-	-	-	-
Mov Cap-1 Maneuver	-	-	1235	-	301	725
Mov Cap-2 Maneuver	-	-	-	-	301	-
Stage 1	-	-	-	-	740	-
Stage 2	-	-	-	-	535	-

Approach	SE	NW	NE
HCM Control Delay, s	0	1.8	11.7
HCM LOS			B

Minor Lane/Major Mvmt	NELn1	NELn2	NWL	NWT	SET	SER
Capacity (veh/h)	301	725	1235	-	-	-
HCM Lane V/C Ratio	0.045	0.191	0.081	-	-	-
HCM Control Delay (s)	17.5	11.1	8.2	-	-	-
HCM Lane LOS	C	B	A	-	-	-
HCM 95th %tile Q(veh)	0.1	0.7	0.3	-	-	-

Intersection

Int Delay, s/veh 8.9

Movement SEL SET NWT NWR SWL SWR

Lane Configurations	↘	↗	↗	↘	↘	↘
Traffic Vol, veh/h	230	183	188	28	112	199
Future Vol, veh/h	230	183	188	28	112	199
Conflicting Peds, #/hr	0	0	0	0	0	0
Sign Control	Free	Free	Free	Free	Stop	Stop
RT Channelized	-	None	-	None	-	None
Storage Length	325	-	-	270	150	0
Veh in Median Storage, #	-	0	0	-	0	-
Grade, %	-	0	0	-	0	-
Peak Hour Factor	88	88	88	88	88	88
Heavy Vehicles, %	2	2	2	2	2	2
Mvmt Flow	261	208	214	32	127	226

Major/Minor Major1 Major2 Minor2

Conflicting Flow All	246	0	-	0	944	214
Stage 1	-	-	-	-	214	-
Stage 2	-	-	-	-	730	-
Critical Hdwy	4.12	-	-	-	6.42	6.22
Critical Hdwy Stg 1	-	-	-	-	5.42	-
Critical Hdwy Stg 2	-	-	-	-	5.42	-
Follow-up Hdwy	2.218	-	-	-	3.518	3.318
Pot Cap-1 Maneuver	1320	-	-	-	291	826
Stage 1	-	-	-	-	822	-
Stage 2	-	-	-	-	477	-
Platoon blocked, %	-	-	-	-	-	-
Mov Cap-1 Maneuver	1320	-	-	-	233	826
Mov Cap-2 Maneuver	-	-	-	-	233	-
Stage 1	-	-	-	-	659	-
Stage 2	-	-	-	-	477	-

Approach SE NW SW

HCM Control Delay, s	4.7	0	20.6
HCM LOS			C

Minor Lane/Major Mvmt NWT NWR SEL SETSWLn1SWLn2

Capacity (veh/h)	-	-	1320	-	233	826
HCM Lane V/C Ratio	-	-	0.198	-	0.546	0.274
HCM Control Delay (s)	-	-	8.4	-	37.6	11
HCM Lane LOS	-	-	A	-	E	B
HCM 95th %tile Q(veh)	-	-	0.7	-	3	1.1

Intersection						
Int Delay, s/veh	3.2					
Movement	SET	SER	NWL	NWT	NEL	NER
Lane Configurations	↑	↗	↖	↑	↖	↗
Traffic Vol, veh/h	463	15	136	387	22	125
Future Vol, veh/h	463	15	136	387	22	125
Conflicting Peds, #/hr	0	0	0	0	0	0
Sign Control	Free	Free	Free	Free	Stop	Stop
RT Channelized	-	None	-	None	-	None
Storage Length	-	245	485	-	105	0
Veh in Median Storage, #	0	-	-	0	0	-
Grade, %	0	-	-	0	0	-
Peak Hour Factor	88	88	88	88	88	88
Heavy Vehicles, %	2	2	2	2	2	2
Mvmt Flow	526	17	155	440	25	142

Major/Minor	Major1	Major2	Minor1		
Conflicting Flow All	0	0	543	0	1276 526
Stage 1	-	-	-	-	526 -
Stage 2	-	-	-	-	750 -
Critical Hdwy	-	-	4.12	-	6.42 6.22
Critical Hdwy Stg 1	-	-	-	-	5.42 -
Critical Hdwy Stg 2	-	-	-	-	5.42 -
Follow-up Hdwy	-	-	2.218	-	3.518 3.318
Pot Cap-1 Maneuver	-	-	1026	-	184 552
Stage 1	-	-	-	-	593 -
Stage 2	-	-	-	-	467 -
Platoon blocked, %	-	-	-	-	-
Mov Cap-1 Maneuver	-	-	1026	-	156 552
Mov Cap-2 Maneuver	-	-	-	-	156 -
Stage 1	-	-	-	-	593 -
Stage 2	-	-	-	-	396 -

Approach	SE	NW	NE
HCM Control Delay, s	0	2.4	16.6
HCM LOS			C

Minor Lane/Major Mvmt	NELn1	NELn2	NWL	NWT	SET	SER
Capacity (veh/h)	156	552	1026	-	-	-
HCM Lane V/C Ratio	0.16	0.257	0.151	-	-	-
HCM Control Delay (s)	32.4	13.8	9.1	-	-	-
HCM Lane LOS	D	B	A	-	-	-
HCM 95th %tile Q(veh)	0.6	1	0.5	-	-	-

Intersection						
Int Delay, s/veh	16.9					
Movement	SEL	SET	NWT	NWR	SWL	SWR
Lane Configurations	↘	↗	↗	↘	↘	↘
Traffic Vol, veh/h	480	194	238	91	60	279
Future Vol, veh/h	480	194	238	91	60	279
Conflicting Peds, #/hr	0	0	0	0	0	0
Sign Control	Free	Free	Free	Free	Stop	Stop
RT Channelized	-	None	-	None	-	None
Storage Length	325	-	-	270	150	0
Veh in Median Storage, #	-	0	0	-	0	-
Grade, %	-	0	0	-	0	-
Peak Hour Factor	88	88	88	88	88	88
Heavy Vehicles, %	2	2	2	2	2	2
Mvmt Flow	545	220	270	103	68	317

Major/Minor	Major1	Major2	Minor2
Conflicting Flow All	373	0	0
Stage 1	-	-	-
Stage 2	-	-	-
Critical Hdwy	4.12	-	-
Critical Hdwy Stg 1	-	-	-
Critical Hdwy Stg 2	-	-	-
Follow-up Hdwy	2.218	-	-
Pot Cap-1 Maneuver	1185	-	-
Stage 1	-	-	-
Stage 2	-	-	-
Platoon blocked, %	-	-	-
Mov Cap-1 Maneuver	1185	-	-
Mov Cap-2 Maneuver	-	-	-
Stage 1	-	-	-
Stage 2	-	-	-

Approach	SE	NW	SW
HCM Control Delay, s	7.6	0	51.9
HCM LOS			F

Minor Lane/Major Mvmt	NWT	NWR	SEL	SETSWLn1SWLn2
Capacity (veh/h)	-	-	1185	- 65 769
HCM Lane V/C Ratio	-	-	0.46	- 1.049 0.412
HCM Control Delay (s)	-	-	10.6	- 233.5 12.9
HCM Lane LOS	-	-	B	- F B
HCM 95th %tile Q(veh)	-	-	2.5	- 5.3 2

Notes
 -: Volume exceeds capacity \$: Delay exceeds 300s +: Computation Not Defined *: All major volume in platoon

Intersection						
Int Delay, s/veh	2.9					
Movement	SET	SER	NWL	NWT	NEL	NER
Lane Configurations	↑	↗	↘	↑	↘	↗
Traffic Vol, veh/h	225	11	61	260	24	114
Future Vol, veh/h	225	11	61	260	24	114
Conflicting Peds, #/hr	0	0	0	0	0	0
Sign Control	Free	Free	Free	Free	Stop	Stop
RT Channelized	-	None	-	None	-	None
Storage Length	-	245	485	-	105	0
Veh in Median Storage, #	0	-	-	0	0	-
Grade, %	0	-	-	0	0	-
Peak Hour Factor	88	88	88	88	88	88
Heavy Vehicles, %	2	2	2	2	2	2
Mvmt Flow	256	13	69	295	27	130

Major/Minor	Major1	Major2	Minor1			
Conflicting Flow All	0	0	269	0	689	256
Stage 1	-	-	-	-	256	-
Stage 2	-	-	-	-	433	-
Critical Hdwy	-	-	4.12	-	6.42	6.22
Critical Hdwy Stg 1	-	-	-	-	5.42	-
Critical Hdwy Stg 2	-	-	-	-	5.42	-
Follow-up Hdwy	-	-	2.218	-	3.518	3.318
Pot Cap-1 Maneuver	-	-	1295	-	412	783
Stage 1	-	-	-	-	787	-
Stage 2	-	-	-	-	654	-
Platoon blocked, %	-	-	-	-	-	-
Mov Cap-1 Maneuver	-	-	1295	-	390	783
Mov Cap-2 Maneuver	-	-	-	-	390	-
Stage 1	-	-	-	-	787	-
Stage 2	-	-	-	-	619	-

Approach	SE	NW	NE
HCM Control Delay, s	0	1.5	11.3
HCM LOS			B

Minor Lane/Major Mvmt	NELn1	NELn2	NWL	NWT	SET	SER
Capacity (veh/h)	390	783	1295	-	-	-
HCM Lane V/C Ratio	0.07	0.165	0.054	-	-	-
HCM Control Delay (s)	14.9	10.5	7.9	-	-	-
HCM Lane LOS	B	B	A	-	-	-
HCM 95th %tile Q(veh)	0.2	0.6	0.2	-	-	-

Intersection						
Int Delay, s/veh	5					
Movement	SEL	SET	NWT	NWR	SWL	SWR
Lane Configurations	↘	↗	↗	↘	↘	↘
Traffic Vol, veh/h	214	118	193	19	12	141
Future Vol, veh/h	214	118	193	19	12	141
Conflicting Peds, #/hr	0	0	0	0	0	0
Sign Control	Free	Free	Free	Free	Stop	Stop
RT Channelized	-	None	-	None	-	None
Storage Length	325	-	-	270	150	0
Veh in Median Storage, #	-	0	0	-	0	-
Grade, %	-	0	0	-	0	-
Peak Hour Factor	88	88	88	88	88	88
Heavy Vehicles, %	2	2	2	2	2	2
Mvmt Flow	243	134	219	22	14	160

Major/Minor	Major1	Major2	Minor2		
Conflicting Flow All	241	0	0	839	219
Stage 1	-	-	-	219	-
Stage 2	-	-	-	620	-
Critical Hdwy	4.12	-	-	6.42	6.22
Critical Hdwy Stg 1	-	-	-	5.42	-
Critical Hdwy Stg 2	-	-	-	5.42	-
Follow-up Hdwy	2.218	-	-	3.518	3.318
Pot Cap-1 Maneuver	1326	-	-	336	821
Stage 1	-	-	-	817	-
Stage 2	-	-	-	536	-
Platoon blocked, %	-	-	-	-	-
Mov Cap-1 Maneuver	1326	-	-	275	821
Mov Cap-2 Maneuver	-	-	-	275	-
Stage 1	-	-	-	667	-
Stage 2	-	-	-	536	-

Approach	SE	NW	SW
HCM Control Delay, s	5.4	0	11.1
HCM LOS			B

Minor Lane/Major Mvmt	NWT	NWR	SEL	SET	SWLn1	SWLn2
Capacity (veh/h)	-	-	1326	-	275	821
HCM Lane V/C Ratio	-	-	0.183	-	0.05	0.195
HCM Control Delay (s)	-	-	8.3	-	18.8	10.4
HCM Lane LOS	-	-	A	-	C	B
HCM 95th %tile Q(veh)	-	-	0.7	-	0.2	0.7

Intersection						
Int Delay, s/veh	2.8					
Movement	SET	SER	NWL	NWT	NEL	NER
Lane Configurations	↑	↗	↘	↑	↘	↗
Traffic Vol, veh/h	325	18	133	365	12	110
Future Vol, veh/h	325	18	133	365	12	110
Conflicting Peds, #/hr	0	0	0	0	0	0
Sign Control	Free	Free	Free	Free	Stop	Stop
RT Channelized	-	None	-	None	-	None
Storage Length	-	245	485	-	105	0
Veh in Median Storage, #	0	-	-	0	0	-
Grade, %	0	-	-	0	0	-
Peak Hour Factor	88	88	88	88	88	88
Heavy Vehicles, %	2	2	2	2	2	2
Mvmt Flow	369	20	151	415	14	125

Major/Minor	Major1	Major2	Minor1			
Conflicting Flow All	0	0	389	0	1086	369
Stage 1	-	-	-	-	369	-
Stage 2	-	-	-	-	717	-
Critical Hdwy	-	-	4.12	-	6.42	6.22
Critical Hdwy Stg 1	-	-	-	-	5.42	-
Critical Hdwy Stg 2	-	-	-	-	5.42	-
Follow-up Hdwy	-	-	2.218	-	3.518	3.318
Pot Cap-1 Maneuver	-	-	1170	-	239	677
Stage 1	-	-	-	-	699	-
Stage 2	-	-	-	-	484	-
Platoon blocked, %	-	-	-	-	-	-
Mov Cap-1 Maneuver	-	-	1170	-	208	677
Mov Cap-2 Maneuver	-	-	-	-	208	-
Stage 1	-	-	-	-	699	-
Stage 2	-	-	-	-	422	-

Approach	SE	NW	NE
HCM Control Delay, s	0	2.3	12.7
HCM LOS			B

Minor Lane/Major Mvmt	NELn1	NELn2	NWL	NWT	SET	SER
Capacity (veh/h)	208	677	1170	-	-	-
HCM Lane V/C Ratio	0.066	0.185	0.129	-	-	-
HCM Control Delay (s)	23.5	11.5	8.5	-	-	-
HCM Lane LOS	C	B	A	-	-	-
HCM 95th %tile Q(veh)	0.2	0.7	0.4	-	-	-

Intersection						
Int Delay, s/veh	6					
Movement	SEL	SET	NWT	NWR	SWL	SWR
Lane Configurations	↘	↗	↗	↘	↘	↘
Traffic Vol, veh/h	249	199	242	50	25	255
Future Vol, veh/h	249	199	242	50	25	255
Conflicting Peds, #/hr	0	0	0	0	0	0
Sign Control	Free	Free	Free	Free	Stop	Stop
RT Channelized	-	None	-	None	-	None
Storage Length	325	-	-	270	150	0
Veh in Median Storage, #	-	0	0	-	0	-
Grade, %	-	0	0	-	0	-
Peak Hour Factor	88	88	88	88	88	88
Heavy Vehicles, %	2	2	2	2	2	2
Mvmt Flow	283	226	275	57	28	290

Major/Minor	Major1	Major2	Minor2		
Conflicting Flow All	332	0	-	0	1067 275
Stage 1	-	-	-	-	275 -
Stage 2	-	-	-	-	792 -
Critical Hdwy	4.12	-	-	-	6.42 6.22
Critical Hdwy Stg 1	-	-	-	-	5.42 -
Critical Hdwy Stg 2	-	-	-	-	5.42 -
Follow-up Hdwy	2.218	-	-	-	3.518 3.318
Pot Cap-1 Maneuver	1227	-	-	-	246 764
Stage 1	-	-	-	-	771 -
Stage 2	-	-	-	-	446 -
Platoon blocked, %		-	-	-	
Mov Cap-1 Maneuver	1227	-	-	-	189 764
Mov Cap-2 Maneuver	-	-	-	-	189 -
Stage 1	-	-	-	-	593 -
Stage 2	-	-	-	-	446 -

Approach	SE	NW	SW
HCM Control Delay, s	4.9	0	13.9
HCM LOS			B

Minor Lane/Major Mvmt	NWT	NWR	SEL	SET	SWLn1	SWLn2
Capacity (veh/h)	-	-	1227	-	189	764
HCM Lane V/C Ratio	-	-	0.231	-	0.15	0.379
HCM Control Delay (s)	-	-	8.8	-	27.4	12.6
HCM Lane LOS	-	-	A	-	D	B
HCM 95th %tile Q(veh)	-	-	0.9	-	0.5	1.8

HCM 6th TWSC
1: Shadow Mountain Dr & Hwy 73

2025 Weekday Total - Scenario 1
PM Peak

Intersection						
Int Delay, s/veh	4					
Movement	SET	SER	NWL	NWT	NEL	NER
Lane Configurations	↑	↗	↘	↑	↘	↗
Traffic Vol, veh/h	445	28	289	320	9	112
Future Vol, veh/h	445	28	289	320	9	112
Conflicting Peds, #/hr	0	0	0	0	0	0
Sign Control	Free	Free	Free	Free	Stop	Stop
RT Channelized	-	None	-	None	-	None
Storage Length	-	245	485	-	105	0
Veh in Median Storage, #	0	-	-	0	0	-
Grade, %	0	-	-	0	0	-
Peak Hour Factor	88	88	88	88	88	88
Heavy Vehicles, %	2	2	2	2	2	2
Mvmt Flow	506	32	328	364	10	127

Major/Minor	Major1	Major2	Minor1		
Conflicting Flow All	0	0	538	0	1526
Stage 1	-	-	-	-	506
Stage 2	-	-	-	-	1020
Critical Hdwy	-	-	4.12	-	6.42
Critical Hdwy Stg 1	-	-	-	-	5.42
Critical Hdwy Stg 2	-	-	-	-	5.42
Follow-up Hdwy	-	-	2.218	-	3.518
Pot Cap-1 Maneuver	-	-	1030	-	130
Stage 1	-	-	-	-	606
Stage 2	-	-	-	-	348
Platoon blocked, %	-	-	-	-	-
Mov Cap-1 Maneuver	-	-	1030	-	89
Mov Cap-2 Maneuver	-	-	-	-	89
Stage 1	-	-	-	-	606
Stage 2	-	-	-	-	237

Approach	SE	NW	NE
HCM Control Delay, s	0	4.8	16
HCM LOS			C

Minor Lane/Major Mvmt	NELn1	NELn2	NWL	NWT	SET	SER
Capacity (veh/h)	89	566	1030	-	-	-
HCM Lane V/C Ratio	0.115	0.225	0.319	-	-	-
HCM Control Delay (s)	50.6	13.2	10.1	-	-	-
HCM Lane LOS	F	B	B	-	-	-
HCM 95th %tile Q(veh)	0.4	0.9	1.4	-	-	-

Intersection						
Int Delay, s/veh	15.2					
Movement	SEL	SET	NWT	NWR	SWL	SWR
Lane Configurations						
Traffic Vol, veh/h	288	282	197	80	117	411
Future Vol, veh/h	288	282	197	80	117	411
Conflicting Peds, #/hr	0	0	0	0	0	0
Sign Control	Free	Free	Free	Free	Stop	Stop
RT Channelized	-	None	-	None	-	None
Storage Length	325	-	-	270	150	0
Veh in Median Storage, #	-	0	0	-	0	-
Grade, %	-	0	0	-	0	-
Peak Hour Factor	88	88	88	88	88	88
Heavy Vehicles, %	2	2	2	2	2	2
Mvmt Flow	327	320	224	91	133	467

Major/Minor	Major1	Major2	Minor2		
Conflicting Flow All	315	0	-	0	1198 224
Stage 1	-	-	-	-	224 -
Stage 2	-	-	-	-	974 -
Critical Hdwy	4.12	-	-	-	6.42 6.22
Critical Hdwy Stg 1	-	-	-	-	5.42 -
Critical Hdwy Stg 2	-	-	-	-	5.42 -
Follow-up Hdwy	2.218	-	-	-	3.518 3.318
Pot Cap-1 Maneuver	1245	-	-	-	205 815
Stage 1	-	-	-	-	813 -
Stage 2	-	-	-	-	366 -
Platoon blocked, %		-	-	-	
Mov Cap-1 Maneuver	1245	-	-	-	151 815
Mov Cap-2 Maneuver	-	-	-	-	151 -
Stage 1	-	-	-	-	599 -
Stage 2	-	-	-	-	366 -

Approach	SE	NW	SW
HCM Control Delay, s	4.5	0	34.6
HCM LOS			D

Minor Lane/Major Mvmt	NWT	NWR	SEL	SETSWLn1SWLn2		
Capacity (veh/h)	-	-	1245	-	151	815
HCM Lane V/C Ratio	-	-	0.263	-	0.88	0.573
HCM Control Delay (s)	-	-	8.9	-	102.8	15.2
HCM Lane LOS	-	-	A	-	F	C
HCM 95th %tile Q(veh)	-	-	1.1	-	6	3.7

HCM 6th TWSC
 3: Site Access & Shadow Mountain Dr

2025 Weekday Total - Scenario 1
 PM Peak

Intersection						
Int Delay, s/veh	3					
Movement	EBT	EBR	WBL	WBT	NBL	NBR
Lane Configurations						
Traffic Vol, veh/h	75	0	115	130	0	11
Future Vol, veh/h	75	0	115	130	0	11
Conflicting Peds, #/hr	0	0	0	0	0	0
Sign Control	Free	Free	Free	Free	Stop	Stop
RT Channelized	-	None	-	None	-	None
Storage Length	-	-	280	-	0	-
Veh in Median Storage, #	0	-	-	0	0	-
Grade, %	0	-	-	0	0	-
Peak Hour Factor	88	88	88	88	88	88
Heavy Vehicles, %	2	2	2	2	2	2
Mvmt Flow	85	0	131	148	0	13

Major/Minor	Major1	Major2	Minor1	Minor2	Minor3
Conflicting Flow All	0	0	85	0	495
Stage 1	-	-	-	-	85
Stage 2	-	-	-	-	410
Critical Hdwy	-	-	4.12	-	6.42
Critical Hdwy Stg 1	-	-	-	-	5.42
Critical Hdwy Stg 2	-	-	-	-	5.42
Follow-up Hdwy	-	-	2.218	-	3.518
Pot Cap-1 Maneuver	-	-	1512	-	534
Stage 1	-	-	-	-	938
Stage 2	-	-	-	-	670
Platoon blocked, %	-	-	-	-	-
Mov Cap-1 Maneuver	-	-	1512	-	488
Mov Cap-2 Maneuver	-	-	-	-	488
Stage 1	-	-	-	-	938
Stage 2	-	-	-	-	612

Approach	EB	WB	NB
HCM Control Delay, s	0	3.6	8.7
HCM LOS			A

Minor Lane/Major Mvmt	NBLn1	EBT	EBR	WBL	WBT
Capacity (veh/h)	974	-	-	1512	-
HCM Lane V/C Ratio	0.013	-	-	0.086	-
HCM Control Delay (s)	8.7	-	-	7.6	-
HCM Lane LOS	A	-	-	A	-
HCM 95th %tile Q(veh)	0	-	-	0.3	-

HCM 6th TWSC
1: Shadow Mountain Dr & Hwy 73

2025 Saturday Total - Scenario 1
AM Peak

Intersection						
Int Delay, s/veh	4.5					
Movement	SET	SER	NWL	NWT	NEL	NER
Lane Configurations	↑	↗	↘	↑	↘	↗
Traffic Vol, veh/h	277	31	286	303	14	141
Future Vol, veh/h	277	31	286	303	14	141
Conflicting Peds, #/hr	0	0	0	0	0	0
Sign Control	Free	Free	Free	Free	Stop	Stop
RT Channelized	-	None	-	None	-	None
Storage Length	-	245	485	-	105	0
Veh in Median Storage, #	0	-	-	0	0	-
Grade, %	0	-	-	0	0	-
Peak Hour Factor	88	88	88	88	88	88
Heavy Vehicles, %	2	2	2	2	2	2
Mvmt Flow	315	35	325	344	16	160

Major/Minor	Major1	Major2	Minor1		
Conflicting Flow All	0	0	350	0	1309 315
Stage 1	-	-	-	-	315 -
Stage 2	-	-	-	-	994 -
Critical Hdwy	-	-	4.12	-	6.42 6.22
Critical Hdwy Stg 1	-	-	-	-	5.42 -
Critical Hdwy Stg 2	-	-	-	-	5.42 -
Follow-up Hdwy	-	-	2.218	-	3.518 3.318
Pot Cap-1 Maneuver	-	-	1209	-	176 725
Stage 1	-	-	-	-	740 -
Stage 2	-	-	-	-	358 -
Platoon blocked, %	-	-	-	-	-
Mov Cap-1 Maneuver	-	-	1209	-	129 725
Mov Cap-2 Maneuver	-	-	-	-	129 -
Stage 1	-	-	-	-	740 -
Stage 2	-	-	-	-	262 -

Approach	SE	NW	NE
HCM Control Delay, s	0	4.4	13.7
HCM LOS			B

Minor Lane/Major Mvmt	NELn1	NELn2	NWL	NWT	SET	SER
Capacity (veh/h)	129	725	1209	-	-	-
HCM Lane V/C Ratio	0.123	0.221	0.269	-	-	-
HCM Control Delay (s)	36.8	11.4	9.1	-	-	-
HCM Lane LOS	E	B	A	-	-	-
HCM 95th %tile Q(veh)	0.4	0.8	1.1	-	-	-

HCM 6th TWSC
2: Hwy 73 & Barkley Rd

2025 Saturday Total - Scenario 1
AM Peak

Intersection						
Int Delay, s/veh	11					
Movement	SEL	SET	NWT	NWR	SWL	SWR
Lane Configurations	↘	↗	↗	↘	↘	↘
Traffic Vol, veh/h	246	186	221	28	112	364
Future Vol, veh/h	246	186	221	28	112	364
Conflicting Peds, #/hr	0	0	0	0	0	0
Sign Control	Free	Free	Free	Free	Stop	Stop
RT Channelized	-	None	-	None	-	None
Storage Length	325	-	-	270	150	0
Veh in Median Storage, #	-	0	0	-	0	-
Grade, %	-	0	0	-	0	-
Peak Hour Factor	88	88	88	88	88	88
Heavy Vehicles, %	2	2	2	2	2	2
Mvmt Flow	280	211	251	32	127	414

Major/Minor	Major1	Major2	Minor2		
Conflicting Flow All	283	0	-	0	1022 251
Stage 1	-	-	-	-	251 -
Stage 2	-	-	-	-	771 -
Critical Hdwy	4.12	-	-	-	6.42 6.22
Critical Hdwy Stg 1	-	-	-	-	5.42 -
Critical Hdwy Stg 2	-	-	-	-	5.42 -
Follow-up Hdwy	2.218	-	-	-	3.518 3.318
Pot Cap-1 Maneuver	1279	-	-	-	261 788
Stage 1	-	-	-	-	791 -
Stage 2	-	-	-	-	456 -
Platoon blocked, %		-	-	-	
Mov Cap-1 Maneuver	1279	-	-	-	204 788
Mov Cap-2 Maneuver	-	-	-	-	204 -
Stage 1	-	-	-	-	618 -
Stage 2	-	-	-	-	456 -

Approach	SE	NW	SW
HCM Control Delay, s	4.9	0	22.4
HCM LOS			C

Minor Lane/Major Mvmt	NWT	NWR	SEL	SETSWLn1SWLn2		
Capacity (veh/h)	-	-	1279	-	204	788
HCM Lane V/C Ratio	-	-	0.219	-	0.624	0.525
HCM Control Delay (s)	-	-	8.6	-	48.1	14.5
HCM Lane LOS	-	-	A	-	E	B
HCM 95th %tile Q(veh)	-	-	0.8	-	3.6	3.1

Intersection						
Int Delay, s/veh	4.9					
Movement	EBT	EBR	WBL	WBT	NBL	NBR
Lane Configurations						
Traffic Vol, veh/h	90	0	220	65	0	21
Future Vol, veh/h	90	0	220	65	0	21
Conflicting Peds, #/hr	0	0	0	0	0	0
Sign Control	Free	Free	Free	Free	Stop	Stop
RT Channelized	-	None	-	None	-	None
Storage Length	-	-	280	-	0	-
Veh in Median Storage, #	0	-	-	0	0	-
Grade, %	0	-	-	0	0	-
Peak Hour Factor	88	88	88	88	88	88
Heavy Vehicles, %	2	2	2	2	2	2
Mvmt Flow	102	0	250	74	0	24

Major/Minor	Major1	Major2	Minor1		
Conflicting Flow All	0	0	102	0	676
Stage 1	-	-	-	-	102
Stage 2	-	-	-	-	574
Critical Hdwy	-	-	4.12	-	6.42
Critical Hdwy Stg 1	-	-	-	-	5.42
Critical Hdwy Stg 2	-	-	-	-	5.42
Follow-up Hdwy	-	-	2.218	-	3.518
Pot Cap-1 Maneuver	-	-	1490	-	419
Stage 1	-	-	-	-	922
Stage 2	-	-	-	-	563
Platoon blocked, %	-	-	-	-	-
Mov Cap-1 Maneuver	-	-	1490	-	349
Mov Cap-2 Maneuver	-	-	-	-	349
Stage 1	-	-	-	-	922
Stage 2	-	-	-	-	468

Approach	EB	WB	NB
HCM Control Delay, s	0	6.1	8.9
HCM LOS			A

Minor Lane/Major Mvmt	NBLn1	EBT	EBR	WBL	WBT
Capacity (veh/h)	953	-	-	1490	-
HCM Lane V/C Ratio	0.025	-	-	0.168	-
HCM Control Delay (s)	8.9	-	-	7.9	-
HCM Lane LOS	A	-	-	A	-
HCM 95th %tile Q(veh)	0.1	-	-	0.6	-

Intersection						
Int Delay, s/veh	6					
Movement	SET	SER	NWL	NWT	NEL	NER
Lane Configurations	↑	↗	↘	↑	↘	↗
Traffic Vol, veh/h	463	17	149	387	38	264
Future Vol, veh/h	463	17	149	387	38	264
Conflicting Peds, #/hr	0	0	0	0	0	0
Sign Control	Free	Free	Free	Free	Stop	Stop
RT Channelized	-	None	-	None	-	None
Storage Length	-	245	485	-	105	0
Veh in Median Storage, #	0	-	-	0	0	-
Grade, %	0	-	-	0	0	-
Peak Hour Factor	88	88	88	88	88	88
Heavy Vehicles, %	2	2	2	2	2	2
Mvmt Flow	526	19	169	440	43	300

Major/Minor	Major1	Major2	Minor1		
Conflicting Flow All	0	0	545	0	1304 526
Stage 1	-	-	-	-	526 -
Stage 2	-	-	-	-	778 -
Critical Hdwy	-	-	4.12	-	6.42 6.22
Critical Hdwy Stg 1	-	-	-	-	5.42 -
Critical Hdwy Stg 2	-	-	-	-	5.42 -
Follow-up Hdwy	-	-	2.218	-	3.518 3.318
Pot Cap-1 Maneuver	-	-	1024	-	177 552
Stage 1	-	-	-	-	593 -
Stage 2	-	-	-	-	453 -
Platoon blocked, %	-	-	-	-	-
Mov Cap-1 Maneuver	-	-	1024	-	148 552
Mov Cap-2 Maneuver	-	-	-	-	148 -
Stage 1	-	-	-	-	593 -
Stage 2	-	-	-	-	378 -

Approach	SE	NW	NE
HCM Control Delay, s	0	2.6	21.5
HCM LOS			C

Minor Lane/Major Mvmt	NELn1	NELn2	NWL	NWT	SET	SER
Capacity (veh/h)	148	552	1024	-	-	-
HCM Lane V/C Ratio	0.292	0.543	0.165	-	-	-
HCM Control Delay (s)	39	19	9.2	-	-	-
HCM Lane LOS	E	C	A	-	-	-
HCM 95th %tile Q(veh)	1.1	3.2	0.6	-	-	-

HCM 6th TWSC
2: Hwy 73 & Barkley Rd

2025 Saturday Total - Scenario 1
Mid-day Peak

Intersection						
Int Delay, s/veh	36.3					
Movement	SEL	SET	NWT	NWR	SWL	SWR
Lane Configurations	↘	↗	↗	↘	↘	↘
Traffic Vol, veh/h	596	217	240	91	60	290
Future Vol, veh/h	596	217	240	91	60	290
Conflicting Peds, #/hr	0	0	0	0	0	0
Sign Control	Free	Free	Free	Free	Stop	Stop
RT Channelized	-	None	-	None	-	None
Storage Length	325	-	-	270	150	0
Veh in Median Storage, #	-	0	0	-	0	-
Grade, %	-	0	0	-	0	-
Peak Hour Factor	88	88	88	88	88	88
Heavy Vehicles, %	2	2	2	2	2	2
Mvmt Flow	677	247	273	103	68	330

Major/Minor	Major1	Major2	Minor2		
Conflicting Flow All	376	0	-	0	1874 273
Stage 1	-	-	-	-	273 -
Stage 2	-	-	-	-	1601 -
Critical Hdwy	4.12	-	-	-	6.42 6.22
Critical Hdwy Stg 1	-	-	-	-	5.42 -
Critical Hdwy Stg 2	-	-	-	-	5.42 -
Follow-up Hdwy	2.218	-	-	-	3.518 3.318
Pot Cap-1 Maneuver	1182	-	-	-	79 766
Stage 1	-	-	-	-	773 -
Stage 2	-	-	-	-	182 -
Platoon blocked, %		-	-	-	
Mov Cap-1 Maneuver	1182	-	-	-	~ 34 766
Mov Cap-2 Maneuver	-	-	-	-	~ 34 -
Stage 1	-	-	-	-	330 -
Stage 2	-	-	-	-	182 -

Approach	SE	NW	SW
HCM Control Delay, s	8.8	0	134.4
HCM LOS			F

Minor Lane/Major Mvmt	NWT	NWR	SEL	SETSWLn1SWLn2	
Capacity (veh/h)	-	-	1182	-	34 766
HCM Lane V/C Ratio	-	-	0.573	-	2.005 0.43
HCM Control Delay (s)	-	-	12	-	720.1 13.2
HCM Lane LOS	-	-	B	-	F B
HCM 95th %tile Q(veh)	-	-	3.8	-	7.6 2.2

Notes
 -: Volume exceeds capacity \$: Delay exceeds 300s +: Computation Not Defined *: All major volume in platoon

Intersection						
Int Delay, s/veh	4.3					
Movement	EBT	EBR	WBL	WBT	NBL	NBR
Lane Configurations						
Traffic Vol, veh/h	110	0	15	100	0	155
Future Vol, veh/h	110	0	15	100	0	155
Conflicting Peds, #/hr	0	0	0	0	0	0
Sign Control	Free	Free	Free	Free	Stop	Stop
RT Channelized	-	None	-	None	-	None
Storage Length	-	-	280	-	0	-
Veh in Median Storage, #	0	-	-	0	0	-
Grade, %	0	-	-	0	0	-
Peak Hour Factor	88	88	88	88	88	88
Heavy Vehicles, %	2	2	2	2	2	2
Mvmt Flow	125	0	17	114	0	176

Major/Minor	Major1	Major2	Minor1		
Conflicting Flow All	0	0	125	0	273
Stage 1	-	-	-	-	125
Stage 2	-	-	-	-	148
Critical Hdwy	-	-	4.12	-	6.42
Critical Hdwy Stg 1	-	-	-	-	5.42
Critical Hdwy Stg 2	-	-	-	-	5.42
Follow-up Hdwy	-	-	2.218	-	3.518
Pot Cap-1 Maneuver	-	-	1462	-	716
Stage 1	-	-	-	-	901
Stage 2	-	-	-	-	880
Platoon blocked, %	-	-	-	-	-
Mov Cap-1 Maneuver	-	-	1462	-	707
Mov Cap-2 Maneuver	-	-	-	-	707
Stage 1	-	-	-	-	901
Stage 2	-	-	-	-	869

Approach	EB	WB	NB
HCM Control Delay, s	0	1	9.8
HCM LOS			A

Minor Lane/Major Mvmt	NBLn1	EBT	EBR	WBL	WBT
Capacity (veh/h)	926	-	-	1462	-
HCM Lane V/C Ratio	0.19	-	-	0.012	-
HCM Control Delay (s)	9.8	-	-	7.5	-
HCM Lane LOS	A	-	-	A	-
HCM 95th %tile Q(veh)	0.7	-	-	0	-

HCM 6th TWSC
1: Shadow Mountain Dr & Hwy 73

2025 Sunday Total - Scenario 1
AM Peak

Intersection						
Int Delay, s/veh	4.7					
Movement	SET	SER	NWL	NWT	NEL	NER
Lane Configurations	↑	↗	↘	↑	↘	↗
Traffic Vol, veh/h	225	33	259	260	26	133
Future Vol, veh/h	225	33	259	260	26	133
Conflicting Peds, #/hr	0	0	0	0	0	0
Sign Control	Free	Free	Free	Free	Stop	Stop
RT Channelized	-	None	-	None	-	None
Storage Length	-	245	485	-	105	0
Veh in Median Storage, #	0	-	-	0	0	-
Grade, %	0	-	-	0	0	-
Peak Hour Factor	88	88	88	88	88	88
Heavy Vehicles, %	2	2	2	2	2	2
Mvmt Flow	256	38	294	295	30	151

Major/Minor	Major1	Major2	Minor1
Conflicting Flow All	0	0	294
Stage 1	-	-	-
Stage 2	-	-	-
Critical Hdwy	-	-	4.12
Critical Hdwy Stg 1	-	-	-
Critical Hdwy Stg 2	-	-	-
Follow-up Hdwy	-	-	2.218
Pot Cap-1 Maneuver	-	-	1268
Stage 1	-	-	-
Stage 2	-	-	-
Platoon blocked, %	-	-	-
Mov Cap-1 Maneuver	-	-	1268
Mov Cap-2 Maneuver	-	-	-
Stage 1	-	-	-
Stage 2	-	-	-

Approach	SE	NW	NE
HCM Control Delay, s	0	4.3	13.9
HCM LOS			B

Minor Lane/Major Mvmt	NELn1	NELn2	NWL	NWT	SET	SER
Capacity (veh/h)	171	783	1268	-	-	-
HCM Lane V/C Ratio	0.173	0.193	0.232	-	-	-
HCM Control Delay (s)	30.4	10.7	8.7	-	-	-
HCM Lane LOS	D	B	A	-	-	-
HCM 95th %tile Q(veh)	0.6	0.7	0.9	-	-	-

Intersection						
Int Delay, s/veh	6.8					
Movement	SEL	SET	NWT	NWR	SWL	SWR
Lane Configurations	↘	↗	↗	↘	↘	↘
Traffic Vol, veh/h	230	121	226	19	12	306
Future Vol, veh/h	230	121	226	19	12	306
Conflicting Peds, #/hr	0	0	0	0	0	0
Sign Control	Free	Free	Free	Free	Stop	Stop
RT Channelized	-	None	-	None	-	None
Storage Length	325	-	-	270	150	0
Veh in Median Storage, #	-	0	0	-	0	-
Grade, %	-	0	0	-	0	-
Peak Hour Factor	88	88	88	88	88	88
Heavy Vehicles, %	2	2	2	2	2	2
Mvmt Flow	261	138	257	22	14	348

Major/Minor	Major1	Major2	Minor2		
Conflicting Flow All	279	0	0	917	257
Stage 1	-	-	-	257	-
Stage 2	-	-	-	660	-
Critical Hdwy	4.12	-	-	6.42	6.22
Critical Hdwy Stg 1	-	-	-	5.42	-
Critical Hdwy Stg 2	-	-	-	5.42	-
Follow-up Hdwy	2.218	-	-	3.518	3.318
Pot Cap-1 Maneuver	1284	-	-	302	782
Stage 1	-	-	-	786	-
Stage 2	-	-	-	514	-
Platoon blocked, %	-	-	-	-	-
Mov Cap-1 Maneuver	1284	-	-	241	782
Mov Cap-2 Maneuver	-	-	-	241	-
Stage 1	-	-	-	626	-
Stage 2	-	-	-	514	-

Approach	SE	NW	SW
HCM Control Delay, s	5.6	0	13.5
HCM LOS			B

Minor Lane/Major Mvmt	NWT	NWR	SEL	SETSWLn1SWLn2		
Capacity (veh/h)	-	-	1284	-	241	782
HCM Lane V/C Ratio	-	-	0.204	-	0.057	0.445
HCM Control Delay (s)	-	-	8.5	-	20.8	13.2
HCM Lane LOS	-	-	A	-	C	B
HCM 95th %tile Q(veh)	-	-	0.8	-	0.2	2.3

Intersection						
Int Delay, s/veh	5					
Movement	EBT	EBR	WBL	WBT	NBL	NBR
Lane Configurations						
Traffic Vol, veh/h	85	0	220	60	0	21
Future Vol, veh/h	85	0	220	60	0	21
Conflicting Peds, #/hr	0	0	0	0	0	0
Sign Control	Free	Free	Free	Free	Stop	Stop
RT Channelized	-	None	-	None	-	None
Storage Length	-	-	280	-	0	-
Veh in Median Storage, #	0	-	-	0	0	-
Grade, %	0	-	-	0	0	-
Peak Hour Factor	88	88	88	88	88	88
Heavy Vehicles, %	2	2	2	2	2	2
Mvmt Flow	97	0	250	68	0	24

Major/Minor	Major1	Major2	Minor1		
Conflicting Flow All	0	0	97	0	665
Stage 1	-	-	-	-	97
Stage 2	-	-	-	-	568
Critical Hdwy	-	-	4.12	-	6.42
Critical Hdwy Stg 1	-	-	-	-	5.42
Critical Hdwy Stg 2	-	-	-	-	5.42
Follow-up Hdwy	-	-	2.218	-	3.518
Pot Cap-1 Maneuver	-	-	1496	-	425
Stage 1	-	-	-	-	927
Stage 2	-	-	-	-	567
Platoon blocked, %	-	-	-	-	-
Mov Cap-1 Maneuver	-	-	1496	-	354
Mov Cap-2 Maneuver	-	-	-	-	354
Stage 1	-	-	-	-	927
Stage 2	-	-	-	-	472

Approach	EB	WB	NB
HCM Control Delay, s	0	6.2	8.9
HCM LOS			A

Minor Lane/Major Mvmt	NBLn1	EBT	EBR	WBL	WBT
Capacity (veh/h)	959	-	-	1496	-
HCM Lane V/C Ratio	0.025	-	-	0.167	-
HCM Control Delay (s)	8.9	-	-	7.9	-
HCM Lane LOS	A	-	-	A	-
HCM 95th %tile Q(veh)	0.1	-	-	0.6	-

HCM 6th TWSC
1: Shadow Mountain Dr & Hwy 73

2025 Sunday Total - Scenario 1
Mid-day Peak

Intersection						
Int Delay, s/veh	4.9					
Movement	SET	SER	NWL	NWT	NEL	NER
Lane Configurations	↑	↗	↖	↑	↖	↗
Traffic Vol, veh/h	325	20	146	365	28	249
Future Vol, veh/h	325	20	146	365	28	249
Conflicting Peds, #/hr	0	0	0	0	0	0
Sign Control	Free	Free	Free	Free	Stop	Stop
RT Channelized	-	None	-	None	-	None
Storage Length	-	245	485	-	105	0
Veh in Median Storage, #	0	-	-	0	0	-
Grade, %	0	-	-	0	0	-
Peak Hour Factor	88	88	88	88	88	88
Heavy Vehicles, %	2	2	2	2	2	2
Mvmt Flow	369	23	166	415	32	283

Major/Minor	Major1	Major2	Minor1		
Conflicting Flow All	0	0	392	0	1116 369
Stage 1	-	-	-	-	369 -
Stage 2	-	-	-	-	747 -
Critical Hdwy	-	-	4.12	-	6.42 6.22
Critical Hdwy Stg 1	-	-	-	-	5.42 -
Critical Hdwy Stg 2	-	-	-	-	5.42 -
Follow-up Hdwy	-	-	2.218	-	3.518 3.318
Pot Cap-1 Maneuver	-	-	1167	-	230 677
Stage 1	-	-	-	-	699 -
Stage 2	-	-	-	-	468 -
Platoon blocked, %	-	-	-	-	-
Mov Cap-1 Maneuver	-	-	1167	-	197 677
Mov Cap-2 Maneuver	-	-	-	-	197 -
Stage 1	-	-	-	-	699 -
Stage 2	-	-	-	-	402 -

Approach	SE	NW	NE
HCM Control Delay, s	0	2.5	15.4
HCM LOS			C

Minor Lane/Major Mvmt	NELn1	NELn2	NWL	NWT	SET	SER
Capacity (veh/h)	197	677	1167	-	-	-
HCM Lane V/C Ratio	0.162	0.418	0.142	-	-	-
HCM Control Delay (s)	26.8	14.1	8.6	-	-	-
HCM Lane LOS	D	B	A	-	-	-
HCM 95th %tile Q(veh)	0.6	2.1	0.5	-	-	-

Intersection						
Int Delay, s/veh	6.9					
Movement	SEL	SET	NWT	NWR	SWL	SWR
Lane Configurations	↘	↗	↗	↘	↘	↘
Traffic Vol, veh/h	365	222	244	50	25	266
Future Vol, veh/h	365	222	244	50	25	266
Conflicting Peds, #/hr	0	0	0	0	0	0
Sign Control	Free	Free	Free	Free	Stop	Stop
RT Channelized	-	None	-	None	-	None
Storage Length	325	-	-	270	150	0
Veh in Median Storage, #	-	0	0	-	0	-
Grade, %	-	0	0	-	0	-
Peak Hour Factor	88	88	88	88	88	88
Heavy Vehicles, %	2	2	2	2	2	2
Mvmt Flow	415	252	277	57	28	302

Major/Minor	Major1	Major2	Minor2		
Conflicting Flow All	334	0	-	0	1359 277
Stage 1	-	-	-	-	277 -
Stage 2	-	-	-	-	1082 -
Critical Hdwy	4.12	-	-	-	6.42 6.22
Critical Hdwy Stg 1	-	-	-	-	5.42 -
Critical Hdwy Stg 2	-	-	-	-	5.42 -
Follow-up Hdwy	2.218	-	-	-	3.518 3.318
Pot Cap-1 Maneuver	1225	-	-	-	164 762
Stage 1	-	-	-	-	770 -
Stage 2	-	-	-	-	325 -
Platoon blocked, %		-	-	-	
Mov Cap-1 Maneuver	1225	-	-	-	108 762
Mov Cap-2 Maneuver	-	-	-	-	108 -
Stage 1	-	-	-	-	509 -
Stage 2	-	-	-	-	325 -

Approach	SE	NW	SW
HCM Control Delay, s	5.9	0	16
HCM LOS			C

Minor Lane/Major Mvmt	NWT	NWR	SEL	SET	SWLn1	SWLn2
Capacity (veh/h)	-	-	1225	-	108	762
HCM Lane V/C Ratio	-	-	0.339	-	0.263	0.397
HCM Control Delay (s)	-	-	9.4	-	49.8	12.8
HCM Lane LOS	-	-	A	-	E	B
HCM 95th %tile Q(veh)	-	-	1.5	-	1	1.9

Intersection						
Int Delay, s/veh	4.6					
Movement	EBT	EBR	WBL	WBT	NBL	NBR
Lane Configurations						
Traffic Vol, veh/h	95	0	15	90	0	155
Future Vol, veh/h	95	0	15	90	0	155
Conflicting Peds, #/hr	0	0	0	0	0	0
Sign Control	Free	Free	Free	Free	Stop	Stop
RT Channelized	-	None	-	None	-	None
Storage Length	-	-	280	-	0	-
Veh in Median Storage, #	0	-	-	0	0	-
Grade, %	0	-	-	0	0	-
Peak Hour Factor	88	88	88	88	88	88
Heavy Vehicles, %	2	2	2	2	2	2
Mvmt Flow	108	0	17	102	0	176

Major/Minor	Major1	Major2	Minor1		
Conflicting Flow All	0	0	108	0	244
Stage 1	-	-	-	-	108
Stage 2	-	-	-	-	136
Critical Hdwy	-	-	4.12	-	6.42
Critical Hdwy Stg 1	-	-	-	-	5.42
Critical Hdwy Stg 2	-	-	-	-	5.42
Follow-up Hdwy	-	-	2.218	-	3.518
Pot Cap-1 Maneuver	-	-	1483	-	744
Stage 1	-	-	-	-	916
Stage 2	-	-	-	-	890
Platoon blocked, %	-	-	-	-	-
Mov Cap-1 Maneuver	-	-	1483	-	736
Mov Cap-2 Maneuver	-	-	-	-	736
Stage 1	-	-	-	-	916
Stage 2	-	-	-	-	880

Approach	EB	WB	NB
HCM Control Delay, s	0	1.1	9.7
HCM LOS			A

Minor Lane/Major Mvmt	NBLn1	EBT	EBR	WBL	WBT
Capacity (veh/h)	946	-	-	1483	-
HCM Lane V/C Ratio	0.186	-	-	0.011	-
HCM Control Delay (s)	9.7	-	-	7.5	-
HCM Lane LOS	A	-	-	A	-
HCM 95th %tile Q(veh)	0.7	-	-	0	-

HCM 6th TWSC
1: Shadow Mountain Dr & Hwy 73

2025 Weekday Total - Scenario 2
PM Peak

Intersection						
Int Delay, s/veh	4					
Movement	SET	SER	NWL	NWT	NEL	NER
Lane Configurations	↑	↗	↘	↑	↘	↗
Traffic Vol, veh/h	445	28	289	320	9	112
Future Vol, veh/h	445	28	289	320	9	112
Conflicting Peds, #/hr	0	0	0	0	0	0
Sign Control	Free	Free	Free	Free	Stop	Stop
RT Channelized	-	None	-	None	-	None
Storage Length	-	245	485	-	105	0
Veh in Median Storage, #	0	-	-	0	0	-
Grade, %	0	-	-	0	0	-
Peak Hour Factor	88	88	88	88	88	88
Heavy Vehicles, %	2	2	2	2	2	2
Mvmt Flow	506	32	328	364	10	127

Major/Minor	Major1	Major2	Minor1	Minor2	Minor3
Conflicting Flow All	0	0	538	0	1526
Stage 1	-	-	-	-	506
Stage 2	-	-	-	-	1020
Critical Hdwy	-	-	4.12	-	6.42
Critical Hdwy Stg 1	-	-	-	-	5.42
Critical Hdwy Stg 2	-	-	-	-	5.42
Follow-up Hdwy	-	-	2.218	-	3.518
Pot Cap-1 Maneuver	-	-	1030	-	130
Stage 1	-	-	-	-	606
Stage 2	-	-	-	-	348
Platoon blocked, %	-	-	-	-	-
Mov Cap-1 Maneuver	-	-	1030	-	89
Mov Cap-2 Maneuver	-	-	-	-	89
Stage 1	-	-	-	-	606
Stage 2	-	-	-	-	237

Approach	SE	NW	NE
HCM Control Delay, s	0	4.8	16
HCM LOS			C

Minor Lane/Major Mvmt	NELn1	NELn2	NWL	NWT	SET	SER
Capacity (veh/h)	89	566	1030	-	-	-
HCM Lane V/C Ratio	0.115	0.225	0.319	-	-	-
HCM Control Delay (s)	50.6	13.2	10.1	-	-	-
HCM Lane LOS	F	B	B	-	-	-
HCM 95th %tile Q(veh)	0.4	0.9	1.4	-	-	-

HCM 6th TWSC
2: Hwy 73 & Barkley Rd

2025 Weekday Total - Scenario 2
PM Peak

Intersection						
Int Delay, s/veh	15.2					
Movement	SEL	SET	NWT	NWR	SWL	SWR
Lane Configurations						
Traffic Vol, veh/h	288	282	197	80	117	411
Future Vol, veh/h	288	282	197	80	117	411
Conflicting Peds, #/hr	0	0	0	0	0	0
Sign Control	Free	Free	Free	Free	Stop	Stop
RT Channelized	-	None	-	None	-	None
Storage Length	325	-	-	270	150	0
Veh in Median Storage, #	-	0	0	-	0	-
Grade, %	-	0	0	-	0	-
Peak Hour Factor	88	88	88	88	88	88
Heavy Vehicles, %	2	2	2	2	2	2
Mvmt Flow	327	320	224	91	133	467

Major/Minor	Major1	Major2	Minor2		
Conflicting Flow All	315	0	-	0	1198 224
Stage 1	-	-	-	-	224 -
Stage 2	-	-	-	-	974 -
Critical Hdwy	4.12	-	-	-	6.42 6.22
Critical Hdwy Stg 1	-	-	-	-	5.42 -
Critical Hdwy Stg 2	-	-	-	-	5.42 -
Follow-up Hdwy	2.218	-	-	-	3.518 3.318
Pot Cap-1 Maneuver	1245	-	-	-	205 815
Stage 1	-	-	-	-	813 -
Stage 2	-	-	-	-	366 -
Platoon blocked, %		-	-	-	
Mov Cap-1 Maneuver	1245	-	-	-	151 815
Mov Cap-2 Maneuver	-	-	-	-	151 -
Stage 1	-	-	-	-	599 -
Stage 2	-	-	-	-	366 -

Approach	SE	NW	SW
HCM Control Delay, s	4.5	0	34.6
HCM LOS			D

Minor Lane/Major Mvmt	NWT	NWR	SEL	SETSWLn1SWLn2		
Capacity (veh/h)	-	-	1245	-	151	815
HCM Lane V/C Ratio	-	-	0.263	-	0.88	0.573
HCM Control Delay (s)	-	-	8.9	-	102.8	15.2
HCM Lane LOS	-	-	A	-	F	C
HCM 95th %tile Q(veh)	-	-	1.1	-	6	3.7

Intersection						
Int Delay, s/veh	2.8					
Movement	EBT	EBR	WBL	WBT	NBL	NBR
Lane Configurations						
Traffic Vol, veh/h	75	0	115	130	0	11
Future Vol, veh/h	75	0	115	130	0	11
Conflicting Peds, #/hr	0	0	0	0	0	0
Sign Control	Free	Free	Free	Free	Stop	Stop
RT Channelized	-	None	-	None	-	Free
Storage Length	-	-	280	-	0	-
Veh in Median Storage, #	0	-	-	0	0	-
Grade, %	0	-	-	0	0	-
Peak Hour Factor	88	88	88	88	88	88
Heavy Vehicles, %	2	2	2	2	2	2
Mvmt Flow	85	0	131	148	0	13

Major/Minor	Major1	Major2	Minor1	Minor2	Minor3
Conflicting Flow All	0	0	85	0	495
Stage 1	-	-	-	-	85
Stage 2	-	-	-	-	410
Critical Hdwy	-	-	4.12	-	6.42
Critical Hdwy Stg 1	-	-	-	-	5.42
Critical Hdwy Stg 2	-	-	-	-	5.42
Follow-up Hdwy	-	-	2.218	-	3.518
Pot Cap-1 Maneuver	-	-	1512	-	534
Stage 1	-	-	-	-	938
Stage 2	-	-	-	-	670
Platoon blocked, %	-	-	-	-	-
Mov Cap-1 Maneuver	-	-	1512	-	488
Mov Cap-2 Maneuver	-	-	-	-	488
Stage 1	-	-	-	-	938
Stage 2	-	-	-	-	612

Approach	EB	WB	NB
HCM Control Delay, s	0	3.6	0
HCM LOS			A

Minor Lane/Major Mvmt	NBLn1	EBT	EBR	WBL	WBT
Capacity (veh/h)	-	-	-	1512	-
HCM Lane V/C Ratio	-	-	-	0.086	-
HCM Control Delay (s)	0	-	-	7.6	-
HCM Lane LOS	A	-	-	A	-
HCM 95th %tile Q(veh)	-	-	-	0.3	-

HCM 6th TWSC
1: Shadow Mountain Dr & Hwy 73

2025 Saturday Total - Scenario 2
AM Peak

Intersection						
Int Delay, s/veh	4.5					
Movement	SET	SER	NWL	NWT	NEL	NER
Lane Configurations	↑	↗	↘	↑	↘	↗
Traffic Vol, veh/h	277	31	286	303	14	141
Future Vol, veh/h	277	31	286	303	14	141
Conflicting Peds, #/hr	0	0	0	0	0	0
Sign Control	Free	Free	Free	Free	Stop	Stop
RT Channelized	-	None	-	None	-	None
Storage Length	-	245	485	-	105	0
Veh in Median Storage, #	0	-	-	0	0	-
Grade, %	0	-	-	0	0	-
Peak Hour Factor	88	88	88	88	88	88
Heavy Vehicles, %	2	2	2	2	2	2
Mvmt Flow	315	35	325	344	16	160

Major/Minor	Major1	Major2	Minor1		
Conflicting Flow All	0	0	350	0	1309 315
Stage 1	-	-	-	-	315 -
Stage 2	-	-	-	-	994 -
Critical Hdwy	-	-	4.12	-	6.42 6.22
Critical Hdwy Stg 1	-	-	-	-	5.42 -
Critical Hdwy Stg 2	-	-	-	-	5.42 -
Follow-up Hdwy	-	-	2.218	-	3.518 3.318
Pot Cap-1 Maneuver	-	-	1209	-	176 725
Stage 1	-	-	-	-	740 -
Stage 2	-	-	-	-	358 -
Platoon blocked, %	-	-	-	-	-
Mov Cap-1 Maneuver	-	-	1209	-	129 725
Mov Cap-2 Maneuver	-	-	-	-	129 -
Stage 1	-	-	-	-	740 -
Stage 2	-	-	-	-	262 -

Approach	SE	NW	NE
HCM Control Delay, s	0	4.4	13.7
HCM LOS			B

Minor Lane/Major Mvmt	NELn1	NELn2	NWL	NWT	SET	SER
Capacity (veh/h)	129	725	1209	-	-	-
HCM Lane V/C Ratio	0.123	0.221	0.269	-	-	-
HCM Control Delay (s)	36.8	11.4	9.1	-	-	-
HCM Lane LOS	E	B	A	-	-	-
HCM 95th %tile Q(veh)	0.4	0.8	1.1	-	-	-

HCM 6th TWSC
2: Hwy 73 & Barkley Rd

2025 Saturday Total - Scenario 2
AM Peak

Intersection						
Int Delay, s/veh	11					
Movement	SEL	SET	NWT	NWR	SWL	SWR
Lane Configurations	↘	↗	↗	↘	↘	↘
Traffic Vol, veh/h	246	186	221	28	112	364
Future Vol, veh/h	246	186	221	28	112	364
Conflicting Peds, #/hr	0	0	0	0	0	0
Sign Control	Free	Free	Free	Free	Stop	Stop
RT Channelized	-	None	-	None	-	None
Storage Length	325	-	-	270	150	0
Veh in Median Storage, #	-	0	0	-	0	-
Grade, %	-	0	0	-	0	-
Peak Hour Factor	88	88	88	88	88	88
Heavy Vehicles, %	2	2	2	2	2	2
Mvmt Flow	280	211	251	32	127	414

Major/Minor	Major1	Major2	Minor2		
Conflicting Flow All	283	0	-	0	1022 251
Stage 1	-	-	-	-	251 -
Stage 2	-	-	-	-	771 -
Critical Hdwy	4.12	-	-	-	6.42 6.22
Critical Hdwy Stg 1	-	-	-	-	5.42 -
Critical Hdwy Stg 2	-	-	-	-	5.42 -
Follow-up Hdwy	2.218	-	-	-	3.518 3.318
Pot Cap-1 Maneuver	1279	-	-	-	261 788
Stage 1	-	-	-	-	791 -
Stage 2	-	-	-	-	456 -
Platoon blocked, %		-	-	-	
Mov Cap-1 Maneuver	1279	-	-	-	204 788
Mov Cap-2 Maneuver	-	-	-	-	204 -
Stage 1	-	-	-	-	618 -
Stage 2	-	-	-	-	456 -

Approach	SE	NW	SW
HCM Control Delay, s	4.9	0	22.4
HCM LOS			C

Minor Lane/Major Mvmt	NWT	NWR	SEL	SET	SWLn1	SWLn2
Capacity (veh/h)	-	-	1279	-	204	788
HCM Lane V/C Ratio	-	-	0.219	-	0.624	0.525
HCM Control Delay (s)	-	-	8.6	-	48.1	14.5
HCM Lane LOS	-	-	A	-	E	B
HCM 95th %tile Q(veh)	-	-	0.8	-	3.6	3.1

Intersection						
Int Delay, s/veh	4.6					
Movement	EBT	EBR	WBL	WBT	NBL	NBR
Lane Configurations						
Traffic Vol, veh/h	90	0	220	65	0	21
Future Vol, veh/h	90	0	220	65	0	21
Conflicting Peds, #/hr	0	0	0	0	0	0
Sign Control	Free	Free	Free	Free	Stop	Stop
RT Channelized	-	None	-	None	-	Free
Storage Length	-	-	280	-	0	-
Veh in Median Storage, #	0	-	-	0	0	-
Grade, %	0	-	-	0	0	-
Peak Hour Factor	88	88	88	88	88	88
Heavy Vehicles, %	2	2	2	2	2	2
Mvmt Flow	102	0	250	74	0	24

Major/Minor	Major1	Major2	Minor1		
Conflicting Flow All	0	0	102	0	676
Stage 1	-	-	-	-	102
Stage 2	-	-	-	-	574
Critical Hdwy	-	-	4.12	-	6.42
Critical Hdwy Stg 1	-	-	-	-	5.42
Critical Hdwy Stg 2	-	-	-	-	5.42
Follow-up Hdwy	-	-	2.218	-	3.518
Pot Cap-1 Maneuver	-	-	1490	-	419
Stage 1	-	-	-	-	922
Stage 2	-	-	-	-	563
Platoon blocked, %	-	-	-	-	-
Mov Cap-1 Maneuver	-	-	1490	-	349
Mov Cap-2 Maneuver	-	-	-	-	349
Stage 1	-	-	-	-	922
Stage 2	-	-	-	-	468

Approach	EB	WB	NB
HCM Control Delay, s	0	6.1	0
HCM LOS			A

Minor Lane/Major Mvmt	NBLn1	EBT	EBR	WBL	WBT
Capacity (veh/h)	-	-	-	1490	-
HCM Lane V/C Ratio	-	-	-	0.168	-
HCM Control Delay (s)	0	-	-	7.9	-
HCM Lane LOS	A	-	-	A	-
HCM 95th %tile Q(veh)	-	-	-	0.6	-

Intersection						
Int Delay, s/veh	6					
Movement	SET	SER	NWL	NWT	NEL	NER
Lane Configurations	↑	↗	↘	↑	↘	↗
Traffic Vol, veh/h	463	17	149	387	38	264
Future Vol, veh/h	463	17	149	387	38	264
Conflicting Peds, #/hr	0	0	0	0	0	0
Sign Control	Free	Free	Free	Free	Stop	Stop
RT Channelized	-	None	-	None	-	None
Storage Length	-	245	485	-	105	0
Veh in Median Storage, #	0	-	-	0	0	-
Grade, %	0	-	-	0	0	-
Peak Hour Factor	88	88	88	88	88	88
Heavy Vehicles, %	2	2	2	2	2	2
Mvmt Flow	526	19	169	440	43	300

Major/Minor	Major1	Major2	Minor1		
Conflicting Flow All	0	0	545	0	1304 526
Stage 1	-	-	-	-	526 -
Stage 2	-	-	-	-	778 -
Critical Hdwy	-	-	4.12	-	6.42 6.22
Critical Hdwy Stg 1	-	-	-	-	5.42 -
Critical Hdwy Stg 2	-	-	-	-	5.42 -
Follow-up Hdwy	-	-	2.218	-	3.518 3.318
Pot Cap-1 Maneuver	-	-	1024	-	177 552
Stage 1	-	-	-	-	593 -
Stage 2	-	-	-	-	453 -
Platoon blocked, %	-	-	-	-	-
Mov Cap-1 Maneuver	-	-	1024	-	148 552
Mov Cap-2 Maneuver	-	-	-	-	148 -
Stage 1	-	-	-	-	593 -
Stage 2	-	-	-	-	378 -

Approach	SE	NW	NE
HCM Control Delay, s	0	2.6	21.5
HCM LOS			C

Minor Lane/Major Mvmt	NELn1	NELn2	NWL	NWT	SET	SER
Capacity (veh/h)	148	552	1024	-	-	-
HCM Lane V/C Ratio	0.292	0.543	0.165	-	-	-
HCM Control Delay (s)	39	19	9.2	-	-	-
HCM Lane LOS	E	C	A	-	-	-
HCM 95th %tile Q(veh)	1.1	3.2	0.6	-	-	-

HCM 6th TWSC
2: Hwy 73 & Barkley Rd

2025 Saturday Total - Scenario 2
Mid-day Peak

Intersection						
Int Delay, s/veh	36.3					
Movement	SEL	SET	NWT	NWR	SWL	SWR
Lane Configurations	↘	↗	↗	↘	↘	↘
Traffic Vol, veh/h	596	217	240	91	60	290
Future Vol, veh/h	596	217	240	91	60	290
Conflicting Peds, #/hr	0	0	0	0	0	0
Sign Control	Free	Free	Free	Free	Stop	Stop
RT Channelized	-	None	-	None	-	None
Storage Length	325	-	-	270	150	0
Veh in Median Storage, #	-	0	0	-	0	-
Grade, %	-	0	0	-	0	-
Peak Hour Factor	88	88	88	88	88	88
Heavy Vehicles, %	2	2	2	2	2	2
Mvmt Flow	677	247	273	103	68	330

Major/Minor	Major1	Major2	Minor2		
Conflicting Flow All	376	0	-	0	1874 273
Stage 1	-	-	-	-	273 -
Stage 2	-	-	-	-	1601 -
Critical Hdwy	4.12	-	-	-	6.42 6.22
Critical Hdwy Stg 1	-	-	-	-	5.42 -
Critical Hdwy Stg 2	-	-	-	-	5.42 -
Follow-up Hdwy	2.218	-	-	-	3.518 3.318
Pot Cap-1 Maneuver	1182	-	-	-	79 766
Stage 1	-	-	-	-	773 -
Stage 2	-	-	-	-	182 -
Platoon blocked, %		-	-	-	
Mov Cap-1 Maneuver	1182	-	-	-	~ 34 766
Mov Cap-2 Maneuver	-	-	-	-	~ 34 -
Stage 1	-	-	-	-	330 -
Stage 2	-	-	-	-	182 -

Approach	SE	NW	SW
HCM Control Delay, s	8.8	0	134.4
HCM LOS			F

Minor Lane/Major Mvmt	NWT	NWR	SEL	SETSWLn1SWLn2	
Capacity (veh/h)	-	-	1182	-	34 766
HCM Lane V/C Ratio	-	-	0.573	-	2.005 0.43
HCM Control Delay (s)	-	-	12	-	720.1 13.2
HCM Lane LOS	-	-	B	-	F B
HCM 95th %tile Q(veh)	-	-	3.8	-	7.6 2.2

Notes
 -: Volume exceeds capacity \$: Delay exceeds 300s +: Computation Not Defined *: All major volume in platoon

Intersection						
Int Delay, s/veh	0.5					
Movement	EBT	EBR	WBL	WBT	NBL	NBR
Lane Configurations						
Traffic Vol, veh/h	110	0	15	100	0	155
Future Vol, veh/h	110	0	15	100	0	155
Conflicting Peds, #/hr	0	0	0	0	0	0
Sign Control	Free	Free	Free	Free	Stop	Stop
RT Channelized	-	None	-	None	-	Free
Storage Length	-	-	280	-	0	-
Veh in Median Storage, #	0	-	-	0	0	-
Grade, %	0	-	-	0	0	-
Peak Hour Factor	88	88	88	88	88	88
Heavy Vehicles, %	2	2	2	2	2	2
Mvmt Flow	125	0	17	114	0	176

Major/Minor	Major1	Major2	Minor1		
Conflicting Flow All	0	0	125	0	273
Stage 1	-	-	-	-	125
Stage 2	-	-	-	-	148
Critical Hdwy	-	-	4.12	-	6.42
Critical Hdwy Stg 1	-	-	-	-	5.42
Critical Hdwy Stg 2	-	-	-	-	5.42
Follow-up Hdwy	-	-	2.218	-	3.518
Pot Cap-1 Maneuver	-	-	1462	-	716
Stage 1	-	-	-	-	901
Stage 2	-	-	-	-	880
Platoon blocked, %	-	-	-	-	-
Mov Cap-1 Maneuver	-	-	1462	-	707
Mov Cap-2 Maneuver	-	-	-	-	707
Stage 1	-	-	-	-	901
Stage 2	-	-	-	-	869

Approach	EB	WB	NB
HCM Control Delay, s	0	1	0
HCM LOS			A

Minor Lane/Major Mvmt	NBLn1	EBT	EBR	WBL	WBT
Capacity (veh/h)	-	-	-	1462	-
HCM Lane V/C Ratio	-	-	-	0.012	-
HCM Control Delay (s)	0	-	-	7.5	-
HCM Lane LOS	A	-	-	A	-
HCM 95th %tile Q(veh)	-	-	-	0	-

HCM 6th TWSC
 1: Shadow Mountain Dr & Hwy 73

2025 Sunday Total - Scenario 2
 AM Peak

Intersection						
Int Delay, s/veh	4.7					
Movement	SET	SER	NWL	NWT	NEL	NER
Lane Configurations	↑	↗	↘	↑	↘	↗
Traffic Vol, veh/h	225	33	259	260	26	133
Future Vol, veh/h	225	33	259	260	26	133
Conflicting Peds, #/hr	0	0	0	0	0	0
Sign Control	Free	Free	Free	Free	Stop	Stop
RT Channelized	-	None	-	None	-	None
Storage Length	-	245	485	-	105	0
Veh in Median Storage, #	0	-	-	0	0	-
Grade, %	0	-	-	0	0	-
Peak Hour Factor	88	88	88	88	88	88
Heavy Vehicles, %	2	2	2	2	2	2
Mvmt Flow	256	38	294	295	30	151

Major/Minor	Major1	Major2	Minor1			
Conflicting Flow All	0	0	294	0	1139	256
Stage 1	-	-	-	-	256	-
Stage 2	-	-	-	-	883	-
Critical Hdwy	-	-	4.12	-	6.42	6.22
Critical Hdwy Stg 1	-	-	-	-	5.42	-
Critical Hdwy Stg 2	-	-	-	-	5.42	-
Follow-up Hdwy	-	-	2.218	-	3.518	3.318
Pot Cap-1 Maneuver	-	-	1268	-	223	783
Stage 1	-	-	-	-	787	-
Stage 2	-	-	-	-	404	-
Platoon blocked, %	-	-	-	-	-	-
Mov Cap-1 Maneuver	-	-	1268	-	171	783
Mov Cap-2 Maneuver	-	-	-	-	171	-
Stage 1	-	-	-	-	787	-
Stage 2	-	-	-	-	310	-

Approach	SE	NW	NE
HCM Control Delay, s	0	4.3	13.9
HCM LOS			B

Minor Lane/Major Mvmt	NELn1	NELn2	NWL	NWT	SET	SER
Capacity (veh/h)	171	783	1268	-	-	-
HCM Lane V/C Ratio	0.173	0.193	0.232	-	-	-
HCM Control Delay (s)	30.4	10.7	8.7	-	-	-
HCM Lane LOS	D	B	A	-	-	-
HCM 95th %tile Q(veh)	0.6	0.7	0.9	-	-	-

Intersection						
Int Delay, s/veh	6.8					
Movement	SEL	SET	NWT	NWR	SWL	SWR
Lane Configurations	↘	↗	↗	↘	↘	↘
Traffic Vol, veh/h	230	121	226	19	12	306
Future Vol, veh/h	230	121	226	19	12	306
Conflicting Peds, #/hr	0	0	0	0	0	0
Sign Control	Free	Free	Free	Free	Stop	Stop
RT Channelized	-	None	-	None	-	None
Storage Length	325	-	-	270	150	0
Veh in Median Storage, #	-	0	0	-	0	-
Grade, %	-	0	0	-	0	-
Peak Hour Factor	88	88	88	88	88	88
Heavy Vehicles, %	2	2	2	2	2	2
Mvmt Flow	261	138	257	22	14	348

Major/Minor	Major1	Major2	Minor2		
Conflicting Flow All	279	0	0	917	257
Stage 1	-	-	-	257	-
Stage 2	-	-	-	660	-
Critical Hdwy	4.12	-	-	6.42	6.22
Critical Hdwy Stg 1	-	-	-	5.42	-
Critical Hdwy Stg 2	-	-	-	5.42	-
Follow-up Hdwy	2.218	-	-	3.518	3.318
Pot Cap-1 Maneuver	1284	-	-	302	782
Stage 1	-	-	-	786	-
Stage 2	-	-	-	514	-
Platoon blocked, %	-	-	-	-	-
Mov Cap-1 Maneuver	1284	-	-	241	782
Mov Cap-2 Maneuver	-	-	-	241	-
Stage 1	-	-	-	626	-
Stage 2	-	-	-	514	-

Approach	SE	NW	SW
HCM Control Delay, s	5.6	0	13.5
HCM LOS			B

Minor Lane/Major Mvmt	NWT	NWR	SEL	SETSWLn1SWLn2		
Capacity (veh/h)	-	-	1284	-	241	782
HCM Lane V/C Ratio	-	-	0.204	-	0.057	0.445
HCM Control Delay (s)	-	-	8.5	-	20.8	13.2
HCM Lane LOS	-	-	A	-	C	B
HCM 95th %tile Q(veh)	-	-	0.8	-	0.2	2.3

Intersection						
Int Delay, s/veh	4.8					
Movement	EBT	EBR	WBL	WBT	NBL	NBR
Lane Configurations						
Traffic Vol, veh/h	85	0	220	60	0	21
Future Vol, veh/h	85	0	220	60	0	21
Conflicting Peds, #/hr	0	0	0	0	0	0
Sign Control	Free	Free	Free	Free	Stop	Stop
RT Channelized	-	None	-	None	-	Free
Storage Length	-	-	280	-	0	-
Veh in Median Storage, #	0	-	-	0	0	-
Grade, %	0	-	-	0	0	-
Peak Hour Factor	88	88	88	88	88	88
Heavy Vehicles, %	2	2	2	2	2	2
Mvmt Flow	97	0	250	68	0	24

Major/Minor	Major1	Major2	Minor1		
Conflicting Flow All	0	0	97	0	665
Stage 1	-	-	-	-	97
Stage 2	-	-	-	-	568
Critical Hdwy	-	-	4.12	-	6.42
Critical Hdwy Stg 1	-	-	-	-	5.42
Critical Hdwy Stg 2	-	-	-	-	5.42
Follow-up Hdwy	-	-	2.218	-	3.518
Pot Cap-1 Maneuver	-	-	1496	-	425
Stage 1	-	-	-	-	927
Stage 2	-	-	-	-	567
Platoon blocked, %	-	-	-	-	-
Mov Cap-1 Maneuver	-	-	1496	-	354
Mov Cap-2 Maneuver	-	-	-	-	354
Stage 1	-	-	-	-	927
Stage 2	-	-	-	-	472

Approach	EB	WB	NB
HCM Control Delay, s	0	6.2	0
HCM LOS			A

Minor Lane/Major Mvmt	NBLn1	EBT	EBR	WBL	WBT
Capacity (veh/h)	-	-	-	1496	-
HCM Lane V/C Ratio	-	-	-	0.167	-
HCM Control Delay (s)	0	-	-	7.9	-
HCM Lane LOS	A	-	-	A	-
HCM 95th %tile Q(veh)	-	-	-	0.6	-

HCM 6th TWSC
1: Shadow Mountain Dr & Hwy 73

2025 Sunday Total - Scenario 2
Mid-day Peak

Intersection						
Int Delay, s/veh	4.9					
Movement	SET	SER	NWL	NWT	NEL	NER
Lane Configurations	↑	↗	↖	↑	↖	↗
Traffic Vol, veh/h	325	20	146	365	28	249
Future Vol, veh/h	325	20	146	365	28	249
Conflicting Peds, #/hr	0	0	0	0	0	0
Sign Control	Free	Free	Free	Free	Stop	Stop
RT Channelized	-	None	-	None	-	None
Storage Length	-	245	485	-	105	0
Veh in Median Storage, #	0	-	-	0	0	-
Grade, %	0	-	-	0	0	-
Peak Hour Factor	88	88	88	88	88	88
Heavy Vehicles, %	2	2	2	2	2	2
Mvmt Flow	369	23	166	415	32	283

Major/Minor	Major1	Major2	Minor1		
Conflicting Flow All	0	0	392	0	1116 369
Stage 1	-	-	-	-	369 -
Stage 2	-	-	-	-	747 -
Critical Hdwy	-	-	4.12	-	6.42 6.22
Critical Hdwy Stg 1	-	-	-	-	5.42 -
Critical Hdwy Stg 2	-	-	-	-	5.42 -
Follow-up Hdwy	-	-	2.218	-	3.518 3.318
Pot Cap-1 Maneuver	-	-	1167	-	230 677
Stage 1	-	-	-	-	699 -
Stage 2	-	-	-	-	468 -
Platoon blocked, %	-	-	-	-	-
Mov Cap-1 Maneuver	-	-	1167	-	197 677
Mov Cap-2 Maneuver	-	-	-	-	197 -
Stage 1	-	-	-	-	699 -
Stage 2	-	-	-	-	402 -

Approach	SE	NW	NE
HCM Control Delay, s	0	2.5	15.4
HCM LOS			C

Minor Lane/Major Mvmt	NELn1	NELn2	NWL	NWT	SET	SER
Capacity (veh/h)	197	677	1167	-	-	-
HCM Lane V/C Ratio	0.162	0.418	0.142	-	-	-
HCM Control Delay (s)	26.8	14.1	8.6	-	-	-
HCM Lane LOS	D	B	A	-	-	-
HCM 95th %tile Q(veh)	0.6	2.1	0.5	-	-	-

Intersection						
Int Delay, s/veh	6.9					
Movement	SEL	SET	NWT	NWR	SWL	SWR
Lane Configurations	↘	↗	↗	↘	↘	↘
Traffic Vol, veh/h	365	222	244	50	25	266
Future Vol, veh/h	365	222	244	50	25	266
Conflicting Peds, #/hr	0	0	0	0	0	0
Sign Control	Free	Free	Free	Free	Stop	Stop
RT Channelized	-	None	-	None	-	None
Storage Length	325	-	-	270	150	0
Veh in Median Storage, #	-	0	0	-	0	-
Grade, %	-	0	0	-	0	-
Peak Hour Factor	88	88	88	88	88	88
Heavy Vehicles, %	2	2	2	2	2	2
Mvmt Flow	415	252	277	57	28	302

Major/Minor	Major1	Major2	Minor2		
Conflicting Flow All	334	0	-	0	1359 277
Stage 1	-	-	-	-	277 -
Stage 2	-	-	-	-	1082 -
Critical Hdwy	4.12	-	-	-	6.42 6.22
Critical Hdwy Stg 1	-	-	-	-	5.42 -
Critical Hdwy Stg 2	-	-	-	-	5.42 -
Follow-up Hdwy	2.218	-	-	-	3.518 3.318
Pot Cap-1 Maneuver	1225	-	-	-	164 762
Stage 1	-	-	-	-	770 -
Stage 2	-	-	-	-	325 -
Platoon blocked, %		-	-	-	
Mov Cap-1 Maneuver	1225	-	-	-	108 762
Mov Cap-2 Maneuver	-	-	-	-	108 -
Stage 1	-	-	-	-	509 -
Stage 2	-	-	-	-	325 -

Approach	SE	NW	SW
HCM Control Delay, s	5.9	0	16
HCM LOS			C

Minor Lane/Major Mvmt	NWT	NWR	SEL	SET	SWLn1	SWLn2
Capacity (veh/h)	-	-	1225	-	108	762
HCM Lane V/C Ratio	-	-	0.339	-	0.263	0.397
HCM Control Delay (s)	-	-	9.4	-	49.8	12.8
HCM Lane LOS	-	-	A	-	E	B
HCM 95th %tile Q(veh)	-	-	1.5	-	1	1.9

Intersection						
Int Delay, s/veh	0.6					
Movement	EBT	EBR	WBL	WBT	NBL	NBR
Lane Configurations						
Traffic Vol, veh/h	95	0	15	90	0	155
Future Vol, veh/h	95	0	15	90	0	155
Conflicting Peds, #/hr	0	0	0	0	0	0
Sign Control	Free	Free	Free	Free	Stop	Stop
RT Channelized	-	None	-	None	-	Free
Storage Length	-	-	280	-	0	-
Veh in Median Storage, #	0	-	-	0	0	-
Grade, %	0	-	-	0	0	-
Peak Hour Factor	88	88	88	88	88	88
Heavy Vehicles, %	2	2	2	2	2	2
Mvmt Flow	108	0	17	102	0	176

Major/Minor	Major1	Major2	Minor1		
Conflicting Flow All	0	0	108	0	244
Stage 1	-	-	-	-	108
Stage 2	-	-	-	-	136
Critical Hdwy	-	-	4.12	-	6.42
Critical Hdwy Stg 1	-	-	-	-	5.42
Critical Hdwy Stg 2	-	-	-	-	5.42
Follow-up Hdwy	-	-	2.218	-	3.518
Pot Cap-1 Maneuver	-	-	1483	-	744
Stage 1	-	-	-	-	916
Stage 2	-	-	-	-	890
Platoon blocked, %	-	-	-	-	-
Mov Cap-1 Maneuver	-	-	1483	-	736
Mov Cap-2 Maneuver	-	-	-	-	736
Stage 1	-	-	-	-	916
Stage 2	-	-	-	-	880

Approach	EB	WB	NB
HCM Control Delay, s	0	1.1	0
HCM LOS			A

Minor Lane/Major Mvmt	NBLn1	EBT	EBR	WBL	WBT
Capacity (veh/h)	-	-	-	1483	-
HCM Lane V/C Ratio	-	-	-	0.011	-
HCM Control Delay (s)	0	-	-	7.5	-
HCM Lane LOS	A	-	-	A	-
HCM 95th %tile Q(veh)	-	-	-	0	-

Intersection			
Intersection Delay, s/veh	9.1		
Intersection LOS	A		
Approach	SE	NW	NE
Entry Lanes	1	1	1
Conflicting Circle Lanes	1	1	1
Adj Approach Flow, veh/h	625	659	136
Demand Flow Rate, veh/h	637	673	139
Vehicles Circulating, veh/h	232	11	614
Vehicles Exiting, veh/h	452	741	255
Ped Vol Crossing Leg, #/h	0	0	0
Ped Cap Adj	1.000	1.000	1.000
Approach Delay, s/veh	10.9	7.8	7.1
Approach LOS	B	A	A
Lane	Left	Left	Left
Designated Moves	TR	LT	LR
Assumed Moves	TR	LT	LR
RT Channelized			
Lane Util	1.000	1.000	1.000
Follow-Up Headway, s	2.609	2.609	2.609
Critical Headway, s	4.976	4.976	4.976
Entry Flow, veh/h	637	673	139
Cap Entry Lane, veh/h	1089	1364	738
Entry HV Adj Factor	0.981	0.980	0.978
Flow Entry, veh/h	625	659	136
Cap Entry, veh/h	1069	1337	722
V/C Ratio	0.585	0.493	0.188
Control Delay, s/veh	10.9	7.8	7.1
LOS	B	A	A
95th %tile Queue, veh	4	3	1

Intersection			
Intersection Delay, s/veh	10.4		
Intersection LOS	B		
Approach	SE	NW	SW
Entry Lanes	1	1	1
Conflicting Circle Lanes	1	1	1
Adj Approach Flow, veh/h	728	335	591
Demand Flow Rate, veh/h	742	342	603
Vehicles Circulating, veh/h	162	371	232
Vehicles Exiting, veh/h	673	533	481
Ped Vol Crossing Leg, #/h	0	0	0
Ped Cap Adj	1.000	1.000	1.000
Approach Delay, s/veh	11.6	7.9	10.2
Approach LOS	B	A	B
Lane	Left	Left	Left
Designated Moves	LT	TR	LR
Assumed Moves	LT	TR	LR
RT Channelized			
Lane Util	1.000	1.000	1.000
Follow-Up Headway, s	2.609	2.609	2.609
Critical Headway, s	4.976	4.976	4.976
Entry Flow, veh/h	742	342	603
Cap Entry Lane, veh/h	1170	945	1089
Entry HV Adj Factor	0.981	0.981	0.980
Flow Entry, veh/h	728	335	591
Cap Entry, veh/h	1147	927	1067
V/C Ratio	0.634	0.362	0.554
Control Delay, s/veh	11.6	7.9	10.2
LOS	B	A	B
95th %tile Queue, veh	5	2	4

HCM 6th Roundabout
1: Shadow Mountain Dr & Hwy 73

2043 Saturday BG
AM Peak

Intersection			
Intersection Delay, s/veh	6.1		
Intersection LOS	A		
Approach	SE	NW	NE
Entry Lanes	1	1	1
Conflicting Circle Lanes	1	1	1
Adj Approach Flow, veh/h	386	518	166
Demand Flow Rate, veh/h	393	528	169
Vehicles Circulating, veh/h	111	15	382
Vehicles Exiting, veh/h	432	536	122
Ped Vol Crossing Leg, #/h	0	0	0
Ped Cap Adj	1.000	1.000	1.000
Approach Delay, s/veh	6.0	6.4	5.7
Approach LOS	A	A	A
Lane	Left	Left	Left
Designated Moves	TR	LT	LR
Assumed Moves	TR	LT	LR
RT Channelized			
Lane Util	1.000	1.000	1.000
Follow-Up Headway, s	2.609	2.609	2.609
Critical Headway, s	4.976	4.976	4.976
Entry Flow, veh/h	393	528	169
Cap Entry Lane, veh/h	1232	1359	935
Entry HV Adj Factor	0.981	0.981	0.982
Flow Entry, veh/h	386	518	166
Cap Entry, veh/h	1209	1333	918
V/C Ratio	0.319	0.389	0.181
Control Delay, s/veh	6.0	6.4	5.7
LOS	A	A	A
95th %tile Queue, veh	1	2	1

Intersection			
Intersection Delay, s/veh	7.8		
Intersection LOS	A		
Approach	SE	NW	SW
Entry Lanes	1	1	1
Conflicting Circle Lanes	1	1	1
Adj Approach Flow, veh/h	556	294	425
Demand Flow Rate, veh/h	567	300	433
Vehicles Circulating, veh/h	155	318	261
Vehicles Exiting, veh/h	539	404	357
Ped Vol Crossing Leg, #/h	0	0	0
Ped Cap Adj	1.000	1.000	1.000
Approach Delay, s/veh	8.4	6.8	7.9
Approach LOS	A	A	A
Lane	Left	Left	Left
Designated Moves	LT	TR	LR
Assumed Moves	LT	TR	LR
RT Channelized			
Lane Util	1.000	1.000	1.000
Follow-Up Headway, s	2.609	2.609	2.609
Critical Headway, s	4.976	4.976	4.976
Entry Flow, veh/h	567	300	433
Cap Entry Lane, veh/h	1178	998	1057
Entry HV Adj Factor	0.981	0.980	0.982
Flow Entry, veh/h	556	294	425
Cap Entry, veh/h	1155	977	1038
V/C Ratio	0.481	0.301	0.410
Control Delay, s/veh	8.4	6.8	7.9
LOS	A	A	A
95th %tile Queue, veh	3	1	2

Intersection			
Intersection Delay, s/veh	9.1		
Intersection LOS	A		
Approach	SE	NW	NE
Entry Lanes	1	1	1
Conflicting Circle Lanes	1	1	1
Adj Approach Flow, veh/h	649	697	183
Demand Flow Rate, veh/h	662	711	187
Vehicles Circulating, veh/h	172	28	644
Vehicles Exiting, veh/h	567	803	190
Ped Vol Crossing Leg, #/h	0	0	0
Ped Cap Adj	1.000	1.000	1.000
Approach Delay, s/veh	10.2	8.4	8.3
Approach LOS	B	A	A
Lane	Left	Left	Left
Designated Moves	TR	LT	LR
Assumed Moves	TR	LT	LR
RT Channelized			
Lane Util	1.000	1.000	1.000
Follow-Up Headway, s	2.609	2.609	2.609
Critical Headway, s	4.976	4.976	4.976
Entry Flow, veh/h	662	711	187
Cap Entry Lane, veh/h	1158	1341	715
Entry HV Adj Factor	0.981	0.981	0.979
Flow Entry, veh/h	649	697	183
Cap Entry, veh/h	1136	1315	700
V/C Ratio	0.572	0.530	0.261
Control Delay, s/veh	10.2	8.4	8.3
LOS	B	A	A
95th %tile Queue, veh	4	3	1

Intersection			
Intersection Delay, s/veh	13.5		
Intersection LOS	B		
Approach	SE	NW	SW
Entry Lanes	1	1	1
Conflicting Circle Lanes	1	1	1
Adj Approach Flow, veh/h	909	437	455
Demand Flow Rate, veh/h	927	445	464
Vehicles Circulating, veh/h	82	661	324
Vehicles Exiting, veh/h	706	348	782
Ped Vol Crossing Leg, #/h	0	0	0
Ped Cap Adj	1.000	1.000	1.000
Approach Delay, s/veh	13.9	16.9	9.3
Approach LOS	B	C	A
Lane	Left	Left	Left
Designated Moves	LT	TR	LR
Assumed Moves	LT	TR	LR
RT Channelized			
Lane Util	1.000	1.000	1.000
Follow-Up Headway, s	2.609	2.609	2.609
Critical Headway, s	4.976	4.976	4.976
Entry Flow, veh/h	927	445	464
Cap Entry Lane, veh/h	1269	703	992
Entry HV Adj Factor	0.980	0.981	0.981
Flow Entry, veh/h	909	437	455
Cap Entry, veh/h	1244	690	972
V/C Ratio	0.730	0.633	0.468
Control Delay, s/veh	13.9	16.9	9.3
LOS	B	C	A
95th %tile Queue, veh	7	5	3

Intersection			
Intersection Delay, s/veh	5.4		
Intersection LOS	A		
Approach	SE	NW	NE
Entry Lanes	1	1	1
Conflicting Circle Lanes	1	1	1
Adj Approach Flow, veh/h	321	428	172
Demand Flow Rate, veh/h	327	437	176
Vehicles Circulating, veh/h	78	31	313
Vehicles Exiting, veh/h	390	458	92
Ped Vol Crossing Leg, #/h	0	0	0
Ped Cap Adj	1.000	1.000	1.000
Approach Delay, s/veh	5.2	5.7	5.3
Approach LOS	A	A	A
Lane	Left	Left	Left
Designated Moves	TR	LT	LR
Assumed Moves	TR	LT	LR
RT Channelized			
Lane Util	1.000	1.000	1.000
Follow-Up Headway, s	2.609	2.609	2.609
Critical Headway, s	4.976	4.976	4.976
Entry Flow, veh/h	327	437	176
Cap Entry Lane, veh/h	1274	1337	1003
Entry HV Adj Factor	0.981	0.979	0.977
Flow Entry, veh/h	321	428	172
Cap Entry, veh/h	1250	1309	980
V/C Ratio	0.257	0.327	0.176
Control Delay, s/veh	5.2	5.7	5.3
LOS	A	A	A
95th %tile Queue, veh	1	1	1

Intersection			
Intersection Delay, s/veh	5.9		
Intersection LOS	A		
Approach	SE	NW	SW
Entry Lanes	1	1	1
Conflicting Circle Lanes	1	1	1
Adj Approach Flow, veh/h	449	287	209
Demand Flow Rate, veh/h	458	293	213
Vehicles Circulating, veh/h	16	296	266
Vehicles Exiting, veh/h	463	178	323
Ped Vol Crossing Leg, #/h	0	0	0
Ped Cap Adj	1.000	1.000	1.000
Approach Delay, s/veh	5.8	6.5	5.4
Approach LOS	A	A	A
Lane	Left	Left	Left
Designated Moves	LT	TR	LR
Assumed Moves	LT	TR	LR
RT Channelized			
Lane Util	1.000	1.000	1.000
Follow-Up Headway, s	2.609	2.609	2.609
Critical Headway, s	4.976	4.976	4.976
Entry Flow, veh/h	458	293	213
Cap Entry Lane, veh/h	1358	1020	1052
Entry HV Adj Factor	0.980	0.979	0.981
Flow Entry, veh/h	449	287	209
Cap Entry, veh/h	1330	999	1032
V/C Ratio	0.337	0.287	0.202
Control Delay, s/veh	5.8	6.5	5.4
LOS	A	A	A
95th %tile Queue, veh	2	1	1

Intersection			
Intersection Delay, s/veh	7.4		
Intersection LOS	A		
Approach	SE	NW	NE
Entry Lanes	1	1	1
Conflicting Circle Lanes	1	1	1
Adj Approach Flow, veh/h	466	659	151
Demand Flow Rate, veh/h	475	672	154
Vehicles Circulating, veh/h	168	15	452
Vehicles Exiting, veh/h	519	591	191
Ped Vol Crossing Leg, #/h	0	0	0
Ped Cap Adj	1.000	1.000	1.000
Approach Delay, s/veh	7.4	7.8	6.0
Approach LOS	A	A	A
Lane	Left	Left	Left
Designated Moves	TR	LT	LR
Assumed Moves	TR	LT	LR
RT Channelized			
Lane Util	1.000	1.000	1.000
Follow-Up Headway, s	2.609	2.609	2.609
Critical Headway, s	4.976	4.976	4.976
Entry Flow, veh/h	475	672	154
Cap Entry Lane, veh/h	1163	1359	870
Entry HV Adj Factor	0.981	0.981	0.981
Flow Entry, veh/h	466	659	151
Cap Entry, veh/h	1141	1333	853
V/C Ratio	0.409	0.495	0.177
Control Delay, s/veh	7.4	7.8	6.0
LOS	A	A	A
95th %tile Queue, veh	2	3	1

Intersection			
Intersection Delay, s/veh	8.0		
Intersection LOS	A		
Approach	SE	NW	SW
Entry Lanes	1	1	1
Conflicting Circle Lanes	1	1	1
Adj Approach Flow, veh/h	608	398	381
Demand Flow Rate, veh/h	620	406	389
Vehicles Circulating, veh/h	35	348	337
Vehicles Exiting, veh/h	691	307	417
Ped Vol Crossing Leg, #/h	0	0	0
Ped Cap Adj	1.000	1.000	1.000
Approach Delay, s/veh	7.5	8.6	8.2
Approach LOS	A	A	A
Lane	Left	Left	Left
Designated Moves	LT	TR	LR
Assumed Moves	LT	TR	LR
RT Channelized			
Lane Util	1.000	1.000	1.000
Follow-Up Headway, s	2.609	2.609	2.609
Critical Headway, s	4.976	4.976	4.976
Entry Flow, veh/h	620	406	389
Cap Entry Lane, veh/h	1331	968	979
Entry HV Adj Factor	0.980	0.981	0.979
Flow Entry, veh/h	608	398	381
Cap Entry, veh/h	1305	949	958
V/C Ratio	0.466	0.420	0.398
Control Delay, s/veh	7.5	8.6	8.2
LOS	A	A	A
95th %tile Queue, veh	3	2	2

Intersection			
Intersection Delay, s/veh	11.3		
Intersection LOS	B		
Approach	SE	NW	NE
Entry Lanes	1	1	1
Conflicting Circle Lanes	1	1	1
Adj Approach Flow, veh/h	638	776	148
Demand Flow Rate, veh/h	651	792	151
Vehicles Circulating, veh/h	351	12	614
Vehicles Exiting, veh/h	453	753	388
Ped Vol Crossing Leg, #/h	0	0	0
Ped Cap Adj	1.000	1.000	1.000
Approach Delay, s/veh	14.7	9.3	7.3
Approach LOS	B	A	A
Lane	Left	Left	Left
Designated Moves	TR	LT	LR
Assumed Moves	TR	LT	LR
RT Channelized			
Lane Util	1.000	1.000	1.000
Follow-Up Headway, s	2.609	2.609	2.609
Critical Headway, s	4.976	4.976	4.976
Entry Flow, veh/h	651	792	151
Cap Entry Lane, veh/h	965	1363	738
Entry HV Adj Factor	0.980	0.980	0.980
Flow Entry, veh/h	638	776	148
Cap Entry, veh/h	945	1336	723
V/C Ratio	0.675	0.581	0.205
Control Delay, s/veh	14.7	9.3	7.3
LOS	B	A	A
95th %tile Queue, veh	5	4	1

Intersection			
Intersection Delay, s/veh	11.6		
Intersection LOS	B		
Approach	SE	NW	SW
Entry Lanes	1	1	1
Conflicting Circle Lanes	1	1	1
Adj Approach Flow, veh/h	739	355	689
Demand Flow Rate, veh/h	753	362	703
Vehicles Circulating, veh/h	162	380	252
Vehicles Exiting, veh/h	793	535	490
Ped Vol Crossing Leg, #/h	0	0	0
Ped Cap Adj	1.000	1.000	1.000
Approach Delay, s/veh	11.8	8.3	13.1
Approach LOS	B	A	B
Lane	Left	Left	Left
Designated Moves	LT	TR	LR
Assumed Moves	LT	TR	LR
RT Channelized			
Lane Util	1.000	1.000	1.000
Follow-Up Headway, s	2.609	2.609	2.609
Critical Headway, s	4.976	4.976	4.976
Entry Flow, veh/h	753	362	703
Cap Entry Lane, veh/h	1170	937	1067
Entry HV Adj Factor	0.981	0.981	0.980
Flow Entry, veh/h	739	355	689
Cap Entry, veh/h	1147	919	1046
V/C Ratio	0.644	0.387	0.659
Control Delay, s/veh	11.8	8.3	13.1
LOS	B	A	B
95th %tile Queue, veh	5	2	5

Intersection						
Int Delay, s/veh	2.7					
Movement	EBT	EBR	WBL	WBT	NBL	NBR
Lane Configurations						
Traffic Vol, veh/h	85	0	115	140	0	11
Future Vol, veh/h	85	0	115	140	0	11
Conflicting Peds, #/hr	0	0	0	0	0	0
Sign Control	Free	Free	Free	Free	Stop	Stop
RT Channelized	-	None	-	None	-	None
Storage Length	-	-	0	-	0	-
Veh in Median Storage, #	0	-	-	0	0	-
Grade, %	0	-	-	0	0	-
Peak Hour Factor	88	88	88	88	88	88
Heavy Vehicles, %	2	2	2	2	2	2
Mvmt Flow	97	0	131	159	0	13

Major/Minor	Major1	Major2	Minor1		
Conflicting Flow All	0	0	97	0	518 97
Stage 1	-	-	-	-	97 -
Stage 2	-	-	-	-	421 -
Critical Hdwy	-	-	4.12	-	6.42 6.22
Critical Hdwy Stg 1	-	-	-	-	5.42 -
Critical Hdwy Stg 2	-	-	-	-	5.42 -
Follow-up Hdwy	-	-	2.218	-	3.518 3.318
Pot Cap-1 Maneuver	-	-	1496	-	518 959
Stage 1	-	-	-	-	927 -
Stage 2	-	-	-	-	662 -
Platoon blocked, %	-	-	-	-	-
Mov Cap-1 Maneuver	-	-	1496	-	472 959
Mov Cap-2 Maneuver	-	-	-	-	472 -
Stage 1	-	-	-	-	927 -
Stage 2	-	-	-	-	604 -

Approach	EB	WB	NB
HCM Control Delay, s	0	3.4	8.8
HCM LOS			A

Minor Lane/Major Mvmt	NBLn1	EBT	EBR	WBL	WBT
Capacity (veh/h)	959	-	-	1496	-
HCM Lane V/C Ratio	0.013	-	-	0.087	-
HCM Control Delay (s)	8.8	-	-	7.6	-
HCM Lane LOS	A	-	-	A	-
HCM 95th %tile Q(veh)	0	-	-	0.3	-

Intersection			
Intersection Delay, s/veh	8.4		
Intersection LOS	A		
Approach	SE	NW	NE
Entry Lanes	1	1	1
Conflicting Circle Lanes	1	1	1
Adj Approach Flow, veh/h	411	743	190
Demand Flow Rate, veh/h	419	758	193
Vehicles Circulating, veh/h	341	17	382
Vehicles Exiting, veh/h	434	558	378
Ped Vol Crossing Leg, #/h	0	0	0
Ped Cap Adj	1.000	1.000	1.000
Approach Delay, s/veh	8.7	8.9	6.0
Approach LOS	A	A	A
Lane	Left	Left	Left
Designated Moves	TR	LT	LR
Assumed Moves	TR	LT	LR
RT Channelized			
Lane Util	1.000	1.000	1.000
Follow-Up Headway, s	2.609	2.609	2.609
Critical Headway, s	4.976	4.976	4.976
Entry Flow, veh/h	419	758	193
Cap Entry Lane, veh/h	975	1356	935
Entry HV Adj Factor	0.980	0.980	0.984
Flow Entry, veh/h	411	743	190
Cap Entry, veh/h	955	1329	920
V/C Ratio	0.430	0.559	0.207
Control Delay, s/veh	8.7	8.9	6.0
LOS	A	A	A
95th %tile Queue, veh	2	4	1

Intersection			
Intersection Delay, s/veh	9.9		
Intersection LOS	A		
Approach	SE	NW	SW
Entry Lanes	1	1	1
Conflicting Circle Lanes	1	1	1
Adj Approach Flow, veh/h	579	331	612
Demand Flow Rate, veh/h	591	338	624
Vehicles Circulating, veh/h	155	338	299
Vehicles Exiting, veh/h	768	408	377
Ped Vol Crossing Leg, #/h	0	0	0
Ped Cap Adj	1.000	1.000	1.000
Approach Delay, s/veh	8.7	7.5	12.2
Approach LOS	A	A	B
Lane	Left	Left	Left
Designated Moves	LT	TR	LR
Assumed Moves	LT	TR	LR
RT Channelized			
Lane Util	1.000	1.000	1.000
Follow-Up Headway, s	2.609	2.609	2.609
Critical Headway, s	4.976	4.976	4.976
Entry Flow, veh/h	591	338	624
Cap Entry Lane, veh/h	1178	978	1017
Entry HV Adj Factor	0.980	0.980	0.981
Flow Entry, veh/h	579	331	612
Cap Entry, veh/h	1154	958	998
V/C Ratio	0.502	0.346	0.613
Control Delay, s/veh	8.7	7.5	12.2
LOS	A	A	B
95th %tile Queue, veh	3	2	4

Intersection						
Int Delay, s/veh	4.7					
Movement	EBT	EBR	WBL	WBT	NBL	NBR
Lane Configurations						
Traffic Vol, veh/h	100	0	220	70	0	21
Future Vol, veh/h	100	0	220	70	0	21
Conflicting Peds, #/hr	0	0	0	0	0	0
Sign Control	Free	Free	Free	Free	Stop	Stop
RT Channelized	-	None	-	None	-	None
Storage Length	-	-	0	-	0	-
Veh in Median Storage, #	0	-	-	0	0	-
Grade, %	0	-	-	0	0	-
Peak Hour Factor	88	88	88	88	88	88
Heavy Vehicles, %	2	2	2	2	2	2
Mvmt Flow	114	0	250	80	0	24

Major/Minor	Major1	Major2	Minor1	Minor2	Minor3
Conflicting Flow All	0	0	114	0	694
Stage 1	-	-	-	-	114
Stage 2	-	-	-	-	580
Critical Hdwy	-	-	4.12	-	6.42
Critical Hdwy Stg 1	-	-	-	-	5.42
Critical Hdwy Stg 2	-	-	-	-	5.42
Follow-up Hdwy	-	-	2.218	-	3.518
Pot Cap-1 Maneuver	-	-	1475	-	409
Stage 1	-	-	-	-	911
Stage 2	-	-	-	-	560
Platoon blocked, %	-	-	-	-	-
Mov Cap-1 Maneuver	-	-	1475	-	340
Mov Cap-2 Maneuver	-	-	-	-	340
Stage 1	-	-	-	-	911
Stage 2	-	-	-	-	465

Approach	EB	WB	NB
HCM Control Delay, s	0	6	8.9
HCM LOS			A

Minor Lane/Major Mvmt	NBLn1	EBT	EBR	WBL	WBT
Capacity (veh/h)	939	-	-	1475	-
HCM Lane V/C Ratio	0.025	-	-	0.169	-
HCM Control Delay (s)	8.9	-	-	7.9	-
HCM Lane LOS	A	-	-	A	-
HCM 95th %tile Q(veh)	0.1	-	-	0.6	-

Intersection			
Intersection Delay, s/veh	10.4		
Intersection LOS	B		
Approach	SE	NW	NE
Entry Lanes	1	1	1
Conflicting Circle Lanes	1	1	1
Adj Approach Flow, veh/h	651	712	359
Demand Flow Rate, veh/h	664	727	366
Vehicles Circulating, veh/h	188	46	644
Vehicles Exiting, veh/h	585	964	208
Ped Vol Crossing Leg, #/h	0	0	0
Ped Cap Adj	1.000	1.000	1.000
Approach Delay, s/veh	10.5	8.9	12.9
Approach LOS	B	A	B
Lane	Left	Left	Left
Designated Moves	TR	LT	LR
Assumed Moves	TR	LT	LR
RT Channelized			
Lane Util	1.000	1.000	1.000
Follow-Up Headway, s	2.609	2.609	2.609
Critical Headway, s	4.976	4.976	4.976
Entry Flow, veh/h	664	727	366
Cap Entry Lane, veh/h	1139	1317	715
Entry HV Adj Factor	0.981	0.980	0.981
Flow Entry, veh/h	651	712	359
Cap Entry, veh/h	1117	1290	702
V/C Ratio	0.583	0.552	0.512
Control Delay, s/veh	10.5	8.9	12.9
LOS	B	A	B
95th %tile Queue, veh	4	4	3

Intersection			
Intersection Delay, s/veh20.0			
Intersection LOS C			
Approach	SE	NW	SW
Entry Lanes	1	1	1
Conflicting Circle Lanes	1	1	1
Adj Approach Flow, veh/h	1073	450	475
Demand Flow Rate, veh/h	1095	459	485
Vehicles Circulating, veh/h	84	801	333
Vehicles Exiting, veh/h	734	378	927
Ped Vol Crossing Leg, #/h	0	0	0
Ped Cap Adj	1.000	1.000	1.000
Approach Delay, s/veh	22.1	25.8	9.8
Approach LOS	C	D	A
Lane	Left	Left	Left
Designated Moves	LT	TR	LR
Assumed Moves	LT	TR	LR
RT Channelized			
Lane Util	1.000	1.000	1.000
Follow-Up Headway, s	2.609	2.609	2.609
Critical Headway, s	4.976	4.976	4.976
Entry Flow, veh/h	1095	459	485
Cap Entry Lane, veh/h	1267	610	983
Entry HV Adj Factor	0.980	0.981	0.979
Flow Entry, veh/h	1073	450	475
Cap Entry, veh/h	1241	598	962
V/C Ratio	0.865	0.753	0.494
Control Delay, s/veh	22.1	25.8	9.8
LOS	C	D	A
95th %tile Queue, veh	12	7	3

Intersection						
Int Delay, s/veh	4.1					
Movement	EBT	EBR	WBL	WBT	NBL	NBR
Lane Configurations						
Traffic Vol, veh/h	120	0	15	110	0	155
Future Vol, veh/h	120	0	15	110	0	155
Conflicting Peds, #/hr	0	0	0	0	0	0
Sign Control	Free	Free	Free	Free	Stop	Stop
RT Channelized	-	None	-	None	-	None
Storage Length	-	-	0	-	0	-
Veh in Median Storage, #	0	-	-	0	0	-
Grade, %	0	-	-	0	0	-
Peak Hour Factor	88	88	88	88	88	88
Heavy Vehicles, %	2	2	2	2	2	2
Mvmt Flow	136	0	17	125	0	176

Major/Minor	Major1	Major2	Minor1		
Conflicting Flow All	0	0	136	0	295
Stage 1	-	-	-	-	136
Stage 2	-	-	-	-	159
Critical Hdwy	-	-	4.12	-	6.42
Critical Hdwy Stg 1	-	-	-	-	5.42
Critical Hdwy Stg 2	-	-	-	-	5.42
Follow-up Hdwy	-	-	2.218	-	3.518
Pot Cap-1 Maneuver	-	-	1448	-	696
Stage 1	-	-	-	-	890
Stage 2	-	-	-	-	870
Platoon blocked, %	-	-	-	-	-
Mov Cap-1 Maneuver	-	-	1448	-	688
Mov Cap-2 Maneuver	-	-	-	-	688
Stage 1	-	-	-	-	890
Stage 2	-	-	-	-	860

Approach	EB	WB	NB
HCM Control Delay, s	0	0.9	9.9
HCM LOS			A

Minor Lane/Major Mvmt	NBLn1	EBT	EBR	WBL	WBT
Capacity (veh/h)	913	-	-	1448	-
HCM Lane V/C Ratio	0.193	-	-	0.012	-
HCM Control Delay (s)	9.9	-	-	7.5	-
HCM Lane LOS	A	-	-	A	-
HCM 95th %tile Q(veh)	0.7	-	-	0	-

Intersection			
Intersection Delay, s/veh	7.4		
Intersection LOS	A		
Approach	SE	NW	NE
Entry Lanes	1	1	1
Conflicting Circle Lanes	1	1	1
Adj Approach Flow, veh/h	346	653	196
Demand Flow Rate, veh/h	353	666	200
Vehicles Circulating, veh/h	307	33	313
Vehicles Exiting, veh/h	392	480	347
Ped Vol Crossing Leg, #/h	0	0	0
Ped Cap Adj	1.000	1.000	1.000
Approach Delay, s/veh	7.3	8.0	5.6
Approach LOS	A	A	A
Lane	Left	Left	Left
Designated Moves	TR	LT	LR
Assumed Moves	TR	LT	LR
RT Channelized			
Lane Util	1.000	1.000	1.000
Follow-Up Headway, s	2.609	2.609	2.609
Critical Headway, s	4.976	4.976	4.976
Entry Flow, veh/h	353	666	200
Cap Entry Lane, veh/h	1009	1334	1003
Entry HV Adj Factor	0.980	0.980	0.980
Flow Entry, veh/h	346	653	196
Cap Entry, veh/h	989	1308	983
V/C Ratio	0.350	0.499	0.199
Control Delay, s/veh	7.3	8.0	5.6
LOS	A	A	A
95th %tile Queue, veh	2	3	1

Intersection			
Intersection Delay, s/veh	7.0		
Intersection LOS	A		
Approach	SE	NW	SW
Entry Lanes	1	1	1
Conflicting Circle Lanes	1	1	1
Adj Approach Flow, veh/h	470	325	397
Demand Flow Rate, veh/h	479	332	405
Vehicles Circulating, veh/h	16	314	305
Vehicles Exiting, veh/h	694	181	341
Ped Vol Crossing Leg, #/h	0	0	0
Ped Cap Adj	1.000	1.000	1.000
Approach Delay, s/veh	5.9	7.1	8.0
Approach LOS	A	A	A
Lane	Left	Left	Left
Designated Moves	LT	TR	LR
Assumed Moves	LT	TR	LR
RT Channelized			
Lane Util	1.000	1.000	1.000
Follow-Up Headway, s	2.609	2.609	2.609
Critical Headway, s	4.976	4.976	4.976
Entry Flow, veh/h	479	332	405
Cap Entry Lane, veh/h	1358	1002	1011
Entry HV Adj Factor	0.981	0.979	0.980
Flow Entry, veh/h	470	325	397
Cap Entry, veh/h	1331	981	991
V/C Ratio	0.353	0.331	0.401
Control Delay, s/veh	5.9	7.1	8.0
LOS	A	A	A
95th %tile Queue, veh	2	1	2

Intersection						
Int Delay, s/veh	4.8					
Movement	EBT	EBR	WBL	WBT	NBL	NBR
Lane Configurations						
Traffic Vol, veh/h	95	0	220	65	0	21
Future Vol, veh/h	95	0	220	65	0	21
Conflicting Peds, #/hr	0	0	0	0	0	0
Sign Control	Free	Free	Free	Free	Stop	Stop
RT Channelized	-	None	-	None	-	None
Storage Length	-	-	0	-	0	-
Veh in Median Storage, #	0	-	-	0	0	-
Grade, %	0	-	-	0	0	-
Peak Hour Factor	88	88	88	88	88	88
Heavy Vehicles, %	2	2	2	2	2	2
Mvmt Flow	108	0	250	74	0	24

Major/Minor	Major1	Major2	Minor1		
Conflicting Flow All	0	0	108	0	682
Stage 1	-	-	-	-	108
Stage 2	-	-	-	-	574
Critical Hdwy	-	-	4.12	-	6.42
Critical Hdwy Stg 1	-	-	-	-	5.42
Critical Hdwy Stg 2	-	-	-	-	5.42
Follow-up Hdwy	-	-	2.218	-	3.518
Pot Cap-1 Maneuver	-	-	1483	-	415
Stage 1	-	-	-	-	916
Stage 2	-	-	-	-	563
Platoon blocked, %	-	-	-	-	-
Mov Cap-1 Maneuver	-	-	1483	-	345
Mov Cap-2 Maneuver	-	-	-	-	345
Stage 1	-	-	-	-	916
Stage 2	-	-	-	-	468

Approach	EB	WB	NB
HCM Control Delay, s	0	6.1	8.9
HCM LOS			A

Minor Lane/Major Mvmt	NBLn1	EBT	EBR	WBL	WBT
Capacity (veh/h)	946	-	-	1483	-
HCM Lane V/C Ratio	0.025	-	-	0.169	-
HCM Control Delay (s)	8.9	-	-	7.9	-
HCM Lane LOS	A	-	-	A	-
HCM 95th %tile Q(veh)	0.1	-	-	0.6	-

HCM 6th Roundabout
1: Shadow Mountain Dr & Hwy 73

2043 Total Sunday - Scenario 1
Mid-day Peak

Intersection			
Intersection Delay, s/veh	8.1		
Intersection LOS	A		
Approach	SE	NW	NE
Entry Lanes	1	1	1
Conflicting Circle Lanes	1	1	1
Adj Approach Flow, veh/h	468	674	327
Demand Flow Rate, veh/h	478	688	334
Vehicles Circulating, veh/h	184	34	452
Vehicles Exiting, veh/h	538	752	209
Ped Vol Crossing Leg, #/h	0	0	0
Ped Cap Adj	1.000	1.000	1.000
Approach Delay, s/veh	7.6	8.2	8.8
Approach LOS	A	A	A
Lane	Left	Left	Left
Designated Moves	TR	LT	LR
Assumed Moves	TR	LT	LR
RT Channelized			
Lane Util	1.000	1.000	1.000
Follow-Up Headway, s	2.609	2.609	2.609
Critical Headway, s	4.976	4.976	4.976
Entry Flow, veh/h	478	688	334
Cap Entry Lane, veh/h	1144	1333	870
Entry HV Adj Factor	0.979	0.980	0.979
Flow Entry, veh/h	468	674	327
Cap Entry, veh/h	1120	1306	852
V/C Ratio	0.418	0.516	0.384
Control Delay, s/veh	7.6	8.2	8.8
LOS	A	A	A
95th %tile Queue, veh	2	3	2

Intersection			
Intersection Delay, s/veh	9.6		
Intersection LOS	A		
Approach	SE	NW	SW
Entry Lanes	1	1	1
Conflicting Circle Lanes	1	1	1
Adj Approach Flow, veh/h	766	400	393
Demand Flow Rate, veh/h	781	408	401
Vehicles Circulating, veh/h	35	482	339
Vehicles Exiting, veh/h	705	334	551
Ped Vol Crossing Leg, #/h	0	0	0
Ped Cap Adj	1.000	1.000	1.000
Approach Delay, s/veh	9.5	10.8	8.4
Approach LOS	A	B	A
Lane	Left	Left	Left
Designated Moves	LT	TR	LR
Assumed Moves	LT	TR	LR
RT Channelized			
Lane Util	1.000	1.000	1.000
Follow-Up Headway, s	2.609	2.609	2.609
Critical Headway, s	4.976	4.976	4.976
Entry Flow, veh/h	781	408	401
Cap Entry Lane, veh/h	1331	844	977
Entry HV Adj Factor	0.981	0.981	0.980
Flow Entry, veh/h	766	400	393
Cap Entry, veh/h	1306	828	957
V/C Ratio	0.587	0.483	0.411
Control Delay, s/veh	9.5	10.8	8.4
LOS	A	B	A
95th %tile Queue, veh	4	3	2

Intersection						
Int Delay, s/veh	4.4					
Movement	EBT	EBR	WBL	WBT	NBL	NBR
Lane Configurations						
Traffic Vol, veh/h	105	0	15	100	0	155
Future Vol, veh/h	105	0	15	100	0	155
Conflicting Peds, #/hr	0	0	0	0	0	0
Sign Control	Free	Free	Free	Free	Stop	Stop
RT Channelized	-	None	-	None	-	None
Storage Length	-	-	0	-	0	-
Veh in Median Storage, #	0	-	-	0	0	-
Grade, %	0	-	-	0	0	-
Peak Hour Factor	88	88	88	88	88	88
Heavy Vehicles, %	2	2	2	2	2	2
Mvmt Flow	119	0	17	114	0	176

Major/Minor	Major1	Major2	Minor1		
Conflicting Flow All	0	0	119	0	267
Stage 1	-	-	-	-	119
Stage 2	-	-	-	-	148
Critical Hdwy	-	-	4.12	-	6.42
Critical Hdwy Stg 1	-	-	-	-	5.42
Critical Hdwy Stg 2	-	-	-	-	5.42
Follow-up Hdwy	-	-	2.218	-	3.518
Pot Cap-1 Maneuver	-	-	1469	-	722
Stage 1	-	-	-	-	906
Stage 2	-	-	-	-	880
Platoon blocked, %	-	-	-	-	-
Mov Cap-1 Maneuver	-	-	1469	-	713
Mov Cap-2 Maneuver	-	-	-	-	713
Stage 1	-	-	-	-	906
Stage 2	-	-	-	-	869

Approach	EB	WB	NB
HCM Control Delay, s	0	1	9.8
HCM LOS			A

Minor Lane/Major Mvmt	NBLn1	EBT	EBR	WBL	WBT
Capacity (veh/h)	933	-	-	1469	-
HCM Lane V/C Ratio	0.189	-	-	0.012	-
HCM Control Delay (s)	9.8	-	-	7.5	-
HCM Lane LOS	A	-	-	A	-
HCM 95th %tile Q(veh)	0.7	-	-	0	-

Intersection			
Intersection Delay, s/veh	11.3		
Intersection LOS	B		
Approach	SE	NW	NE
Entry Lanes	1	1	1
Conflicting Circle Lanes	1	1	1
Adj Approach Flow, veh/h	638	776	148
Demand Flow Rate, veh/h	651	792	151
Vehicles Circulating, veh/h	351	12	614
Vehicles Exiting, veh/h	453	753	388
Ped Vol Crossing Leg, #/h	0	0	0
Ped Cap Adj	1.000	1.000	1.000
Approach Delay, s/veh	14.7	9.3	7.3
Approach LOS	B	A	A
Lane	Left	Left	Left
Designated Moves	TR	LT	LR
Assumed Moves	TR	LT	LR
RT Channelized			
Lane Util	1.000	1.000	1.000
Follow-Up Headway, s	2.609	2.609	2.609
Critical Headway, s	4.976	4.976	4.976
Entry Flow, veh/h	651	792	151
Cap Entry Lane, veh/h	965	1363	738
Entry HV Adj Factor	0.980	0.980	0.980
Flow Entry, veh/h	638	776	148
Cap Entry, veh/h	945	1336	723
V/C Ratio	0.675	0.581	0.205
Control Delay, s/veh	14.7	9.3	7.3
LOS	B	A	A
95th %tile Queue, veh	5	4	1

Intersection			
Intersection Delay, s/veh	11.6		
Intersection LOS	B		
Approach	SE	NW	SW
Entry Lanes	1	1	1
Conflicting Circle Lanes	1	1	1
Adj Approach Flow, veh/h	739	355	689
Demand Flow Rate, veh/h	753	362	703
Vehicles Circulating, veh/h	162	380	252
Vehicles Exiting, veh/h	793	535	490
Ped Vol Crossing Leg, #/h	0	0	0
Ped Cap Adj	1.000	1.000	1.000
Approach Delay, s/veh	11.8	8.3	13.1
Approach LOS	B	A	B
Lane	Left	Left	Left
Designated Moves	LT	TR	LR
Assumed Moves	LT	TR	LR
RT Channelized			
Lane Util	1.000	1.000	1.000
Follow-Up Headway, s	2.609	2.609	2.609
Critical Headway, s	4.976	4.976	4.976
Entry Flow, veh/h	753	362	703
Cap Entry Lane, veh/h	1170	937	1067
Entry HV Adj Factor	0.981	0.981	0.980
Flow Entry, veh/h	739	355	689
Cap Entry, veh/h	1147	919	1046
V/C Ratio	0.644	0.387	0.659
Control Delay, s/veh	11.8	8.3	13.1
LOS	B	A	B
95th %tile Queue, veh	5	2	5

Intersection						
Int Delay, s/veh	2.6					
Movement	EBT	EBR	WBL	WBT	NBL	NBR
Lane Configurations						
Traffic Vol, veh/h	85	0	115	140	0	11
Future Vol, veh/h	85	0	115	140	0	11
Conflicting Peds, #/hr	0	0	0	0	0	0
Sign Control	Free	Free	Free	Free	Stop	Stop
RT Channelized	-	None	-	None	-	Free
Storage Length	-	-	0	-	0	-
Veh in Median Storage, #	0	-	-	0	0	-
Grade, %	0	-	-	0	0	-
Peak Hour Factor	88	88	88	88	88	88
Heavy Vehicles, %	2	2	2	2	2	2
Mvmt Flow	97	0	131	159	0	13

Major/Minor	Major1	Major2	Minor1		
Conflicting Flow All	0	0	97	0	518
Stage 1	-	-	-	-	97
Stage 2	-	-	-	-	421
Critical Hdwy	-	-	4.12	-	6.42
Critical Hdwy Stg 1	-	-	-	-	5.42
Critical Hdwy Stg 2	-	-	-	-	5.42
Follow-up Hdwy	-	-	2.218	-	3.518
Pot Cap-1 Maneuver	-	-	1496	-	518
Stage 1	-	-	-	-	927
Stage 2	-	-	-	-	662
Platoon blocked, %	-	-	-	-	-
Mov Cap-1 Maneuver	-	-	1496	-	472
Mov Cap-2 Maneuver	-	-	-	-	472
Stage 1	-	-	-	-	927
Stage 2	-	-	-	-	604

Approach	EB	WB	NB
HCM Control Delay, s	0	3.4	0
HCM LOS			A

Minor Lane/Major Mvmt	NBLn1	EBT	EBR	WBL	WBT
Capacity (veh/h)	-	-	-	1496	-
HCM Lane V/C Ratio	-	-	-	0.087	-
HCM Control Delay (s)	0	-	-	7.6	-
HCM Lane LOS	A	-	-	A	-
HCM 95th %tile Q(veh)	-	-	-	0.3	-

HCM 6th Roundabout
 1: Shadow Mountain Dr & Hwy 73

2043 Total Saturday - Scenario 2
 AM Peak

Intersection			
Intersection Delay, s/veh	8.4		
Intersection LOS	A		
Approach	SE	NW	NE
Entry Lanes	1	1	1
Conflicting Circle Lanes	1	1	1
Adj Approach Flow, veh/h	411	743	190
Demand Flow Rate, veh/h	419	758	193
Vehicles Circulating, veh/h	341	17	382
Vehicles Exiting, veh/h	434	558	378
Ped Vol Crossing Leg, #/h	0	0	0
Ped Cap Adj	1.000	1.000	1.000
Approach Delay, s/veh	8.7	8.9	6.0
Approach LOS	A	A	A
Lane	Left	Left	Left
Designated Moves	TR	LT	LR
Assumed Moves	TR	LT	LR
RT Channelized			
Lane Util	1.000	1.000	1.000
Follow-Up Headway, s	2.609	2.609	2.609
Critical Headway, s	4.976	4.976	4.976
Entry Flow, veh/h	419	758	193
Cap Entry Lane, veh/h	975	1356	935
Entry HV Adj Factor	0.980	0.980	0.984
Flow Entry, veh/h	411	743	190
Cap Entry, veh/h	955	1329	920
V/C Ratio	0.430	0.559	0.207
Control Delay, s/veh	8.7	8.9	6.0
LOS	A	A	A
95th %tile Queue, veh	2	4	1

Intersection			
Intersection Delay, s/veh	9.9		
Intersection LOS	A		
Approach	SE	NW	SW
Entry Lanes	1	1	1
Conflicting Circle Lanes	1	1	1
Adj Approach Flow, veh/h	579	331	612
Demand Flow Rate, veh/h	591	338	624
Vehicles Circulating, veh/h	155	338	299
Vehicles Exiting, veh/h	768	408	377
Ped Vol Crossing Leg, #/h	0	0	0
Ped Cap Adj	1.000	1.000	1.000
Approach Delay, s/veh	8.7	7.5	12.2
Approach LOS	A	A	B
Lane	Left	Left	Left
Designated Moves	LT	TR	LR
Assumed Moves	LT	TR	LR
RT Channelized			
Lane Util	1.000	1.000	1.000
Follow-Up Headway, s	2.609	2.609	2.609
Critical Headway, s	4.976	4.976	4.976
Entry Flow, veh/h	591	338	624
Cap Entry Lane, veh/h	1178	978	1017
Entry HV Adj Factor	0.980	0.980	0.981
Flow Entry, veh/h	579	331	612
Cap Entry, veh/h	1154	958	998
V/C Ratio	0.502	0.346	0.613
Control Delay, s/veh	8.7	7.5	12.2
LOS	A	A	B
95th %tile Queue, veh	3	2	4

Intersection						
Int Delay, s/veh	4.5					
Movement	EBT	EBR	WBL	WBT	NBL	NBR
Lane Configurations						
Traffic Vol, veh/h	100	0	220	70	0	21
Future Vol, veh/h	100	0	220	70	0	21
Conflicting Peds, #/hr	0	0	0	0	0	0
Sign Control	Free	Free	Free	Free	Stop	Stop
RT Channelized	-	None	-	None	-	Free
Storage Length	-	-	0	-	0	-
Veh in Median Storage, #	0	-	-	0	0	-
Grade, %	0	-	-	0	0	-
Peak Hour Factor	88	88	88	88	88	88
Heavy Vehicles, %	2	2	2	2	2	2
Mvmt Flow	114	0	250	80	0	24

Major/Minor	Major1	Major2	Minor1	Minor2	Minor3
Conflicting Flow All	0	0	114	0	694
Stage 1	-	-	-	-	114
Stage 2	-	-	-	-	580
Critical Hdwy	-	-	4.12	-	6.42
Critical Hdwy Stg 1	-	-	-	-	5.42
Critical Hdwy Stg 2	-	-	-	-	5.42
Follow-up Hdwy	-	-	2.218	-	3.518
Pot Cap-1 Maneuver	-	-	1475	-	409
Stage 1	-	-	-	-	911
Stage 2	-	-	-	-	560
Platoon blocked, %	-	-	-	-	-
Mov Cap-1 Maneuver	-	-	1475	-	340
Mov Cap-2 Maneuver	-	-	-	-	340
Stage 1	-	-	-	-	911
Stage 2	-	-	-	-	465

Approach	EB	WB	NB
HCM Control Delay, s	0	6	0
HCM LOS			A

Minor Lane/Major Mvmt	NBLn1	EBT	EBR	WBL	WBT
Capacity (veh/h)	-	-	-	1475	-
HCM Lane V/C Ratio	-	-	-	0.169	-
HCM Control Delay (s)	0	-	-	7.9	-
HCM Lane LOS	A	-	-	A	-
HCM 95th %tile Q(veh)	-	-	-	0.6	-

Intersection			
Intersection Delay, s/veh	10.4		
Intersection LOS	B		
Approach	SE	NW	NE
Entry Lanes	1	1	1
Conflicting Circle Lanes	1	1	1
Adj Approach Flow, veh/h	651	712	359
Demand Flow Rate, veh/h	664	727	366
Vehicles Circulating, veh/h	188	46	644
Vehicles Exiting, veh/h	585	964	208
Ped Vol Crossing Leg, #/h	0	0	0
Ped Cap Adj	1.000	1.000	1.000
Approach Delay, s/veh	10.5	8.9	12.9
Approach LOS	B	A	B
Lane	Left	Left	Left
Designated Moves	TR	LT	LR
Assumed Moves	TR	LT	LR
RT Channelized			
Lane Util	1.000	1.000	1.000
Follow-Up Headway, s	2.609	2.609	2.609
Critical Headway, s	4.976	4.976	4.976
Entry Flow, veh/h	664	727	366
Cap Entry Lane, veh/h	1139	1317	715
Entry HV Adj Factor	0.981	0.980	0.981
Flow Entry, veh/h	651	712	359
Cap Entry, veh/h	1117	1290	702
V/C Ratio	0.583	0.552	0.512
Control Delay, s/veh	10.5	8.9	12.9
LOS	B	A	B
95th %tile Queue, veh	4	4	3

Intersection			
Intersection Delay, s/veh20.0			
Intersection LOS C			
Approach	SE	NW	SW
Entry Lanes	1	1	1
Conflicting Circle Lanes	1	1	1
Adj Approach Flow, veh/h	1073	450	475
Demand Flow Rate, veh/h	1095	459	485
Vehicles Circulating, veh/h	84	801	333
Vehicles Exiting, veh/h	734	378	927
Ped Vol Crossing Leg, #/h	0	0	0
Ped Cap Adj	1.000	1.000	1.000
Approach Delay, s/veh	22.1	25.8	9.8
Approach LOS	C	D	A
Lane	Left	Left	Left
Designated Moves	LT	TR	LR
Assumed Moves	LT	TR	LR
RT Channelized			
Lane Util	1.000	1.000	1.000
Follow-Up Headway, s	2.609	2.609	2.609
Critical Headway, s	4.976	4.976	4.976
Entry Flow, veh/h	1095	459	485
Cap Entry Lane, veh/h	1267	610	983
Entry HV Adj Factor	0.980	0.981	0.979
Flow Entry, veh/h	1073	450	475
Cap Entry, veh/h	1241	598	962
V/C Ratio	0.865	0.753	0.494
Control Delay, s/veh	22.1	25.8	9.8
LOS	C	D	A
95th %tile Queue, veh	12	7	3

Intersection						
Int Delay, s/veh	0.5					
Movement	EBT	EBR	WBL	WBT	NBL	NBR
Lane Configurations						
Traffic Vol, veh/h	120	0	15	110	0	155
Future Vol, veh/h	120	0	15	110	0	155
Conflicting Peds, #/hr	0	0	0	0	0	0
Sign Control	Free	Free	Free	Free	Stop	Stop
RT Channelized	-	None	-	None	-	Free
Storage Length	-	-	0	-	0	-
Veh in Median Storage, #	0	-	-	0	0	-
Grade, %	0	-	-	0	0	-
Peak Hour Factor	88	88	88	88	88	88
Heavy Vehicles, %	2	2	2	2	2	2
Mvmt Flow	136	0	17	125	0	176

Major/Minor	Major1	Major2	Minor1		
Conflicting Flow All	0	0	136	0	295
Stage 1	-	-	-	-	136
Stage 2	-	-	-	-	159
Critical Hdwy	-	-	4.12	-	6.42
Critical Hdwy Stg 1	-	-	-	-	5.42
Critical Hdwy Stg 2	-	-	-	-	5.42
Follow-up Hdwy	-	-	2.218	-	3.518
Pot Cap-1 Maneuver	-	-	1448	-	696
Stage 1	-	-	-	-	890
Stage 2	-	-	-	-	870
Platoon blocked, %	-	-	-	-	-
Mov Cap-1 Maneuver	-	-	1448	-	688
Mov Cap-2 Maneuver	-	-	-	-	688
Stage 1	-	-	-	-	890
Stage 2	-	-	-	-	860

Approach	EB	WB	NB
HCM Control Delay, s	0	0.9	0
HCM LOS			A

Minor Lane/Major Mvmt	NBLn1	EBT	EBR	WBL	WBT
Capacity (veh/h)	-	-	-	1448	-
HCM Lane V/C Ratio	-	-	-	0.012	-
HCM Control Delay (s)	0	-	-	7.5	-
HCM Lane LOS	A	-	-	A	-
HCM 95th %tile Q(veh)	-	-	-	0	-

Intersection			
Intersection Delay, s/veh	7.4		
Intersection LOS	A		
Approach	SE	NW	NE
Entry Lanes	1	1	1
Conflicting Circle Lanes	1	1	1
Adj Approach Flow, veh/h	346	653	196
Demand Flow Rate, veh/h	353	666	200
Vehicles Circulating, veh/h	307	33	313
Vehicles Exiting, veh/h	392	480	347
Ped Vol Crossing Leg, #/h	0	0	0
Ped Cap Adj	1.000	1.000	1.000
Approach Delay, s/veh	7.3	8.0	5.6
Approach LOS	A	A	A
Lane	Left	Left	Left
Designated Moves	TR	LT	LR
Assumed Moves	TR	LT	LR
RT Channelized			
Lane Util	1.000	1.000	1.000
Follow-Up Headway, s	2.609	2.609	2.609
Critical Headway, s	4.976	4.976	4.976
Entry Flow, veh/h	353	666	200
Cap Entry Lane, veh/h	1009	1334	1003
Entry HV Adj Factor	0.980	0.980	0.980
Flow Entry, veh/h	346	653	196
Cap Entry, veh/h	989	1308	983
V/C Ratio	0.350	0.499	0.199
Control Delay, s/veh	7.3	8.0	5.6
LOS	A	A	A
95th %tile Queue, veh	2	3	1

Intersection			
Intersection Delay, s/veh	7.0		
Intersection LOS	A		
Approach	SE	NW	SW
Entry Lanes	1	1	1
Conflicting Circle Lanes	1	1	1
Adj Approach Flow, veh/h	470	325	397
Demand Flow Rate, veh/h	479	332	405
Vehicles Circulating, veh/h	16	314	305
Vehicles Exiting, veh/h	694	181	341
Ped Vol Crossing Leg, #/h	0	0	0
Ped Cap Adj	1.000	1.000	1.000
Approach Delay, s/veh	5.9	7.1	8.0
Approach LOS	A	A	A
Lane	Left	Left	Left
Designated Moves	LT	TR	LR
Assumed Moves	LT	TR	LR
RT Channelized			
Lane Util	1.000	1.000	1.000
Follow-Up Headway, s	2.609	2.609	2.609
Critical Headway, s	4.976	4.976	4.976
Entry Flow, veh/h	479	332	405
Cap Entry Lane, veh/h	1358	1002	1011
Entry HV Adj Factor	0.981	0.979	0.980
Flow Entry, veh/h	470	325	397
Cap Entry, veh/h	1331	981	991
V/C Ratio	0.353	0.331	0.401
Control Delay, s/veh	5.9	7.1	8.0
LOS	A	A	A
95th %tile Queue, veh	2	1	2

Intersection						
Int Delay, s/veh	4.6					
Movement	EBT	EBR	WBL	WBT	NBL	NBR
Lane Configurations						
Traffic Vol, veh/h	95	0	220	65	0	21
Future Vol, veh/h	95	0	220	65	0	21
Conflicting Peds, #/hr	0	0	0	0	0	0
Sign Control	Free	Free	Free	Free	Stop	Stop
RT Channelized	-	None	-	None	-	Free
Storage Length	-	-	0	-	0	-
Veh in Median Storage, #	0	-	-	0	0	-
Grade, %	0	-	-	0	0	-
Peak Hour Factor	88	88	88	88	88	88
Heavy Vehicles, %	2	2	2	2	2	2
Mvmt Flow	108	0	250	74	0	24

Major/Minor	Major1	Major2	Minor1		
Conflicting Flow All	0	0	108	0	682
Stage 1	-	-	-	-	108
Stage 2	-	-	-	-	574
Critical Hdwy	-	-	4.12	-	6.42
Critical Hdwy Stg 1	-	-	-	-	5.42
Critical Hdwy Stg 2	-	-	-	-	5.42
Follow-up Hdwy	-	-	2.218	-	3.518
Pot Cap-1 Maneuver	-	-	1483	-	415
Stage 1	-	-	-	-	916
Stage 2	-	-	-	-	563
Platoon blocked, %	-	-	-	-	-
Mov Cap-1 Maneuver	-	-	1483	-	345
Mov Cap-2 Maneuver	-	-	-	-	345
Stage 1	-	-	-	-	916
Stage 2	-	-	-	-	468

Approach	EB	WB	NB
HCM Control Delay, s	0	6.1	0
HCM LOS			A

Minor Lane/Major Mvmt	NBLn1	EBT	EBR	WBL	WBT
Capacity (veh/h)	-	-	-	1483	-
HCM Lane V/C Ratio	-	-	-	0.169	-
HCM Control Delay (s)	0	-	-	7.9	-
HCM Lane LOS	A	-	-	A	-
HCM 95th %tile Q(veh)	-	-	-	0.6	-

Intersection			
Intersection Delay, s/veh	8.1		
Intersection LOS	A		
Approach	SE	NW	NE
Entry Lanes	1	1	1
Conflicting Circle Lanes	1	1	1
Adj Approach Flow, veh/h	468	674	327
Demand Flow Rate, veh/h	478	688	334
Vehicles Circulating, veh/h	184	34	452
Vehicles Exiting, veh/h	538	752	209
Ped Vol Crossing Leg, #/h	0	0	0
Ped Cap Adj	1.000	1.000	1.000
Approach Delay, s/veh	7.6	8.2	8.8
Approach LOS	A	A	A
Lane	Left	Left	Left
Designated Moves	TR	LT	LR
Assumed Moves	TR	LT	LR
RT Channelized			
Lane Util	1.000	1.000	1.000
Follow-Up Headway, s	2.609	2.609	2.609
Critical Headway, s	4.976	4.976	4.976
Entry Flow, veh/h	478	688	334
Cap Entry Lane, veh/h	1144	1333	870
Entry HV Adj Factor	0.979	0.980	0.979
Flow Entry, veh/h	468	674	327
Cap Entry, veh/h	1120	1306	852
V/C Ratio	0.418	0.516	0.384
Control Delay, s/veh	7.6	8.2	8.8
LOS	A	A	A
95th %tile Queue, veh	2	3	2

Intersection			
Intersection Delay, s/veh	9.6		
Intersection LOS	A		
Approach	SE	NW	SW
Entry Lanes	1	1	1
Conflicting Circle Lanes	1	1	1
Adj Approach Flow, veh/h	766	400	393
Demand Flow Rate, veh/h	781	408	401
Vehicles Circulating, veh/h	35	482	339
Vehicles Exiting, veh/h	705	334	551
Ped Vol Crossing Leg, #/h	0	0	0
Ped Cap Adj	1.000	1.000	1.000
Approach Delay, s/veh	9.5	10.8	8.4
Approach LOS	A	B	A
Lane	Left	Left	Left
Designated Moves	LT	TR	LR
Assumed Moves	LT	TR	LR
RT Channelized			
Lane Util	1.000	1.000	1.000
Follow-Up Headway, s	2.609	2.609	2.609
Critical Headway, s	4.976	4.976	4.976
Entry Flow, veh/h	781	408	401
Cap Entry Lane, veh/h	1331	844	977
Entry HV Adj Factor	0.981	0.981	0.980
Flow Entry, veh/h	766	400	393
Cap Entry, veh/h	1306	828	957
V/C Ratio	0.587	0.483	0.411
Control Delay, s/veh	9.5	10.8	8.4
LOS	A	B	A
95th %tile Queue, veh	4	3	2

Intersection						
Int Delay, s/veh	0.5					
Movement	EBT	EBR	WBL	WBT	NBL	NBR
Lane Configurations						
Traffic Vol, veh/h	105	0	15	100	0	155
Future Vol, veh/h	105	0	15	100	0	155
Conflicting Peds, #/hr	0	0	0	0	0	0
Sign Control	Free	Free	Free	Free	Stop	Stop
RT Channelized	-	None	-	None	-	Free
Storage Length	-	-	0	-	0	-
Veh in Median Storage, #	0	-	-	0	0	-
Grade, %	0	-	-	0	0	-
Peak Hour Factor	88	88	88	88	88	88
Heavy Vehicles, %	2	2	2	2	2	2
Mvmt Flow	119	0	17	114	0	176

Major/Minor	Major1	Major2	Minor1		
Conflicting Flow All	0	0	119	0	267
Stage 1	-	-	-	-	119
Stage 2	-	-	-	-	148
Critical Hdwy	-	-	4.12	-	6.42
Critical Hdwy Stg 1	-	-	-	-	5.42
Critical Hdwy Stg 2	-	-	-	-	5.42
Follow-up Hdwy	-	-	2.218	-	3.518
Pot Cap-1 Maneuver	-	-	1469	-	722
Stage 1	-	-	-	-	906
Stage 2	-	-	-	-	880
Platoon blocked, %	-	-	-	-	-
Mov Cap-1 Maneuver	-	-	1469	-	713
Mov Cap-2 Maneuver	-	-	-	-	713
Stage 1	-	-	-	-	906
Stage 2	-	-	-	-	869

Approach	EB	WB	NB
HCM Control Delay, s	0	1	0
HCM LOS			A

Minor Lane/Major Mvmt	NBLn1	EBT	EBR	WBL	WBT
Capacity (veh/h)	-	-	-	1469	-
HCM Lane V/C Ratio	-	-	-	0.012	-
HCM Control Delay (s)	0	-	-	7.5	-
HCM Lane LOS	A	-	-	A	-
HCM 95th %tile Q(veh)	-	-	-	0	-

Visual Analysis

of proposed projects at
Shadow Mountain Bike Park

December 2023

Prepared for:



Shadow Mountain Bike Park

Prepared by:



SE Group
PO Box 2729
Frisco, CO 80443

and

Perkins&Will

Introduction

This visual analysis includes a summary of visual resource management guidelines, a description of the existing visual conditions in the project area, and an analysis of impacts associated with implementation of the proposed project. The analysis also includes mitigation measures designed to minimize or avoid impacts to visual resources.

The proposed project is the development of a lift-served bike park on Shadow Mountain Drive in Conifer, Colorado. The project would require tree clearing and grading to construct a base area that includes parking spaces for up to 300 cars, a guest services facility, and the top and bottom terminals of a chairlift, as well as tree clearing along the lift corridor, bike trails, and service road.

Local Guidelines

Local guidelines for the visual resource include the Conifer/285 Corridor Area Plan and the Jefferson County Zoning Resolution.

Community Plan Compliance

The Jefferson County 2020 Comprehensive Master Plan was originally adopted by the Planning Commission in 2010 and updated in 2020. It includes eight area plans that provide more specific guidance when considering rezoning, special use, or site approval. The Conifer/285 Corridor Area Plan applies to the proposed project area and its direction for the visual resource is provided below.

The perception of open space is enhanced by unrestricted views.

The visual resources of the Conifer/285 Corridor Area are among its most important values. Views of the area's beauty attract people to the community and provide pleasure to its residents. These resources should be protected.

1. *Visually sensitive areas, and landscapes that have special qualities, (e.g. major rock outcrops, mountain meadows, steep slopes, ridgelines and peaks) should be treated as environmentally sensitive areas, and New Development in these areas should only be allowed if visual impacts can be adequately mitigated.*
2. *Visual impacts of New Developments in mountain meadows cannot be adequately mitigated through planting trees.*
3. *If a mountain meadow is discovered on a property, which is not already designated on the Plan Recommendation maps, development should be placed outside of mountain meadows. Buildings may be placed at the edge of meadows within the trees; however, the following items should be taken into consideration for this to occur. Density recommendations should not change.*
 - a. *Using the natural topography to minimize the visual impacts of the buildings, as much as practicable.*
 - b. *Constructing only open-style fencing in the meadow area.*
 - c. *Minimize disturbance in the 'wet' portion of the meadow, if such an area exists.*
4. *In addition, the following should be included in the architectural design.*
 - a. *Using colors that help the structures blend into the natural surroundings.*
 - b. *Using more than one building material. One of the materials used should be stone, faux stone, cultured stone, or timbers.*

- c. *Minimize the impact of other non-building structures on the meadow, such as driveways, septic systems and detention areas.*
- 5. *Structures, roads and utilities should be designed so they do not visually dominate the landscape. Techniques that should be considered include:*
 - a. *Structures should be below the ridgeline, and natural materials and colors should be used;*
 - b. *Roads should be constructed parallel to contours, rather than a bold cut on a hillside; and*
- 6. *Development within activity centers should be designed to achieve a visually cohesive appearance by using natural materials and colors compatible with the mountain backdrop of the area.*¹

A-2 Zoning

The proposed project would be located on a parcel zoned as Agricultural-Two, or A-2. There are no specific guidelines for the visual resource, however, there are guidelines for building heights and other parameters. They are the following:²

Districts	Building Height	Lot Size (see a & b below)
A-1	35 ft.	5 Acre (217,800 s.f.)
A-2	35 ft.	10 Acre (435,600 s.f.)
A-35	35 ft.	35 Acre (1,524,600 s.f.)

Existing Conditions

The existing parcel is undeveloped. It is characterized by slopes from 5 to 25 percent with some steeper areas of rock outcrops. Vegetation consists of mixed conifer, aspen forest, lodgepole pine, agricultural and rocky meadows, as well and some riparian areas and wetlands.³ Most of the proposed development would occur in a meadow area that was previously cleared of vegetation for agricultural purposes. The area has not been identified by the Conifer/285 Corridor Area Plan as a mountain meadow.

Three viewpoints were selected for analysis in order to simulate the visual impacts of the proposed project. These include two viewpoints along Shadow Mountain Drive, one looking west across the meadow at the development, and one looking directly at the proposed base area development and lift corridor. The third viewpoint is from South Warhawk Road from which the lift corridor would likely be visible. These viewpoints were selected because the local community was concerned about modifications to the visual resource from these particular areas and because they are the most frequented areas with direct views of the proposed project area. Many other viewpoints along Shadow Mountain Drive and South Warhawk Road were considered, however, visibility of proposed projects from most other viewpoints considered would be minimal to none. Refer to Figure 1 for a map of the viewpoints included in this analysis.

¹ Conifer/285 Corridor Area Plan, updated 2020

² Jefferson County Zoning Resolution, 2020 Edition, Section 33

³ Shadow Mountain Bike Park Vegetation Assessment, prepared for this application.

Shadow Mountain Drive passes through the parcel and is on the northwestern edge of the proposed parcel for development. This is the main viewpoint from which visitors to the area can see the parcel (refer to Figure 2a). Most viewers currently see the parcel along an approximately 0.75-mile stretch of road while driving along Shadow Mountain Drive. When driving the posted speed limit of 30 miles per hour, there is an approximately 90 second window in which the project area is visible. In its existing condition, the only built structures on the parcel are a wooden fence and metal posts close to the road, where a stream crosses.

South Warhawk Road stems from Shadow Mountain Drive and travels uphill, across from the project parcel to the northeast. Most visitors in this area are residents. While driving, there are short windows where the trees break and reveal the higher elevation areas within the parcel (refer to Figure 4a). This window of visibility only lasts a couple seconds at a time. In its existing condition, the only built structures in view are houses on the mountain side and communications infrastructure along the ridgeline.

Additionally, there are some private residences bordering the project area that have direct views of the parcel. Adjacent residences include homes on the other side of Shadow Mountain Drive, as well as homes directly adjacent to the parcel. Most viewers at these locations are likely local residents in their homes or on their property. The duration of their view likely lasts anywhere between a couple seconds and several minutes, depending on what they are doing.

Proposed Conditions

Development of the proposed project would introduce developed bike park infrastructure and trails into an area that currently exists in a near natural state. The project would result in modest additions to a largely undeveloped landscape when viewed from critical viewpoints.

Specifically, the proposed development would introduce a road, chairlift infrastructure, a parking lot, and a lodge that would be visible from critical viewpoints. Wildfire treatments in the forest and trail clearing corridors may also be visible. The chairlift would have a clearing corridor of up to 50 feet (as depicted in Figures 3b, 3c, and 4b), trails would be up to 20 feet in width, and the access road would be approximately 30 feet in width with clearing of 10 feet on either side. Additionally, the Wildfire Hazard Mitigation Plan includes treatment areas that would result in thinning of forest stands, removal of underbrush, some patch cutting, and additional clearing around the base area. These treatments and clearing areas are depicted in the simulations.

As illustrated in the visual simulations (Figures 2-4), the proposed base area and parking facilities would be prominent in the foreground of viewpoints 1 and 2 and the chairlift and lift corridor would be prominent in the middleground of viewpoint 3. The service road, clearing areas around the lift terminals, and select bike trails would have some visual impacts by creating some gaps in the forest stands (see Figures 2b and 3b). However, these impacts would be minor as they would primarily be seen as additional shadows in the forest and would be shielded by existing vegetation from most views in the analysis area.

As illustrated in Figures 2b and 3b, implementation of the proposed project would introduce recreation infrastructure to the largely undeveloped landscape along Shadow Mountain Drive. Visual impacts would be most severe in the foreground, where the proposed parking facility, base area facility, and

chairlift/terminal would be viewed by members of the public driving down the road. Given the topography, vegetation, and winding nature of Shadow Mountain Drive, it is anticipated that the proposed base area would only be visible for approximately 90 seconds over a 0.75-mile segment of the road. Project-specific design criteria and best management practices would be utilized to minimize or avoid visual impacts from this viewpoint.

As illustrated in Figure 4b, implementation of the proposed project would introduce recreation infrastructure to the largely undeveloped landscape viewed from South Warhawk Road. Visual impacts would be evident in the middleground, where the proposed chairlift, top terminal, and lift corridor would be visible for members of the public driving down the road. Given the topography, vegetation, and winding nature of South Warhawk Road, it is anticipated that the proposed chairlift infrastructure would occasionally become visible in short windows where the trees break and reveal the higher elevation areas within the parcel. These views are not anticipated to last more than a couple of seconds, and project-specific design criteria and best management practices would be utilized to minimize or avoid these impacts. While the proposed projects would introduce recreation infrastructure to the mountainside, with adherence to PDC, the proposed projects would remain visually subordinate to the visual strength of the characteristic landscape.

It is likely that the residences in the area would also experience the visual impacts of the proposed project. These are the areas from which the views would last the longest. The two residences closest to the project parcel (one across from the parcel and one bordered by the project parcel along Shadow Mountain Drive) would have the most direct views of the proposed base area development. The character of their views would change from largely undeveloped to developed.

Mitigation Measures

As demonstrated in Figure 3c, vegetation would be planted and clustered along the edge of the parking lots strategically to screen the base area facility, lift terminal, and bike park activity. While these are not considered mitigation according to the Conifer/285 Corridor Area Plan, they would provide screening of the development for drivers along Shadow Mountain Drive and for the nearby residences.

The planned base area facility would also follow design criteria to mitigate its presence in the viewshed of Shadow Mountain Drive. The building would be nestled into the hillside, minimizing vertically into the majority of the facades. Maximum building height is currently designed at 32'6", compliant with the A-2 building height limit of 35'. The roof planes would be sloped to match the grade of the hillside and 'replace' the hillside that was removed, so one's eye naturally connects the rooflines into the mountainside. Although an exact material palette has not been selected at this point, the building facades will be comprised of natural materials and tones of grey, brown, and black (see Figures 2b and 3b). Utilizing wood, stone, concrete, and steel allows the building to blend into the shadows and trunk lines of the forest surrounding it.

Viewshed Analysis

The viewshed of the proposed project is displayed in Figure 5. This viewshed was analyzed from the highest point within the parcel, from the proposed top lift terminal. As described in the figure, the viewshed displays a 10km (approximately 6.22 mile) radius, where green indicates areas from which the viewpoint would be visible.

The viewshed from this point is primarily visible north and west of the project area. It is likely that the areas further away would have trouble seeing a lift terminal given the presence of vegetation and the scale of it from a distance. This being said, it is likely that the viewshed areas that would be most highly impacted are those closest to the project area.

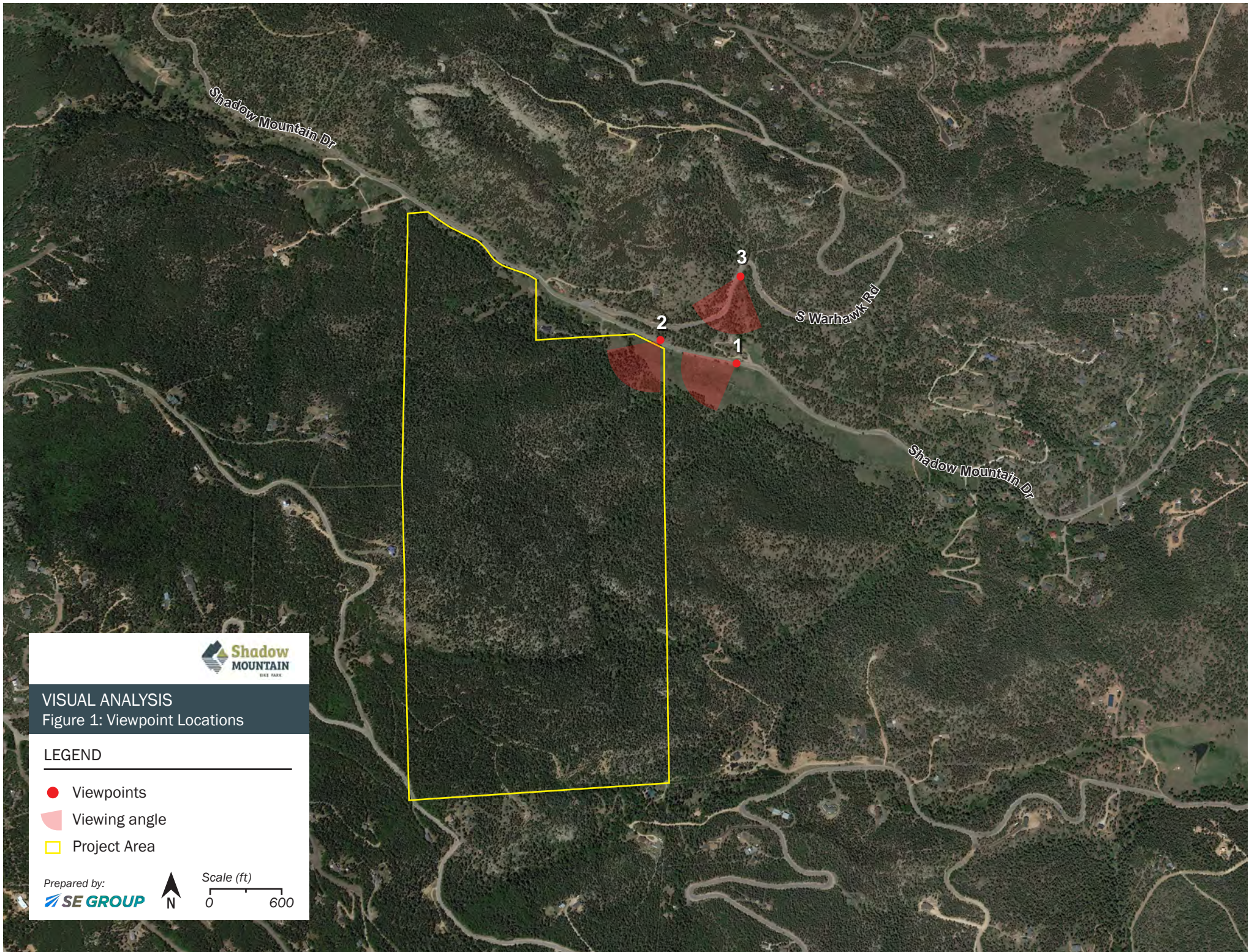

VISUAL ANALYSIS
Figure 1: Viewpoint Locations

LEGEND

- Viewpoints
- Viewing angle
- Project Area

Prepared by:
SE GROUP



Scale (ft)
0 600



VISUAL ANALYSIS
Figure 2a: Viewpoint 1
Shadow Mountain Drive
Existing Conditions



Prepared by:
SE GROUP
and
Perkins&Will





VISUAL ANALYSIS
Figure 2b: Viewpoint 1
Shadow Mountain Drive
Proposed Conditions



Prepared by:
SE GROUP
and
Perkins&Will





VISUAL ANALYSIS
Figure 3a: Viewpoint 2
Shadow Mountain Drive
Existing Conditions





VISUAL ANALYSIS
Figure 3b: Viewpoint 2
Shadow Mountain Drive
Proposed Conditions





VISUAL ANALYSIS
Figure 3c: Viewpoint 2
Shadow Mountain Drive
Proposed Conditions (mitigated)





VISUAL ANALYSIS
Figure 4a: Viewpoint 2
South Warhawk Road
Existing Conditions





VISUAL ANALYSIS
Figure 4b: Viewpoint 2
South Warhawk Road
Proposed Conditions



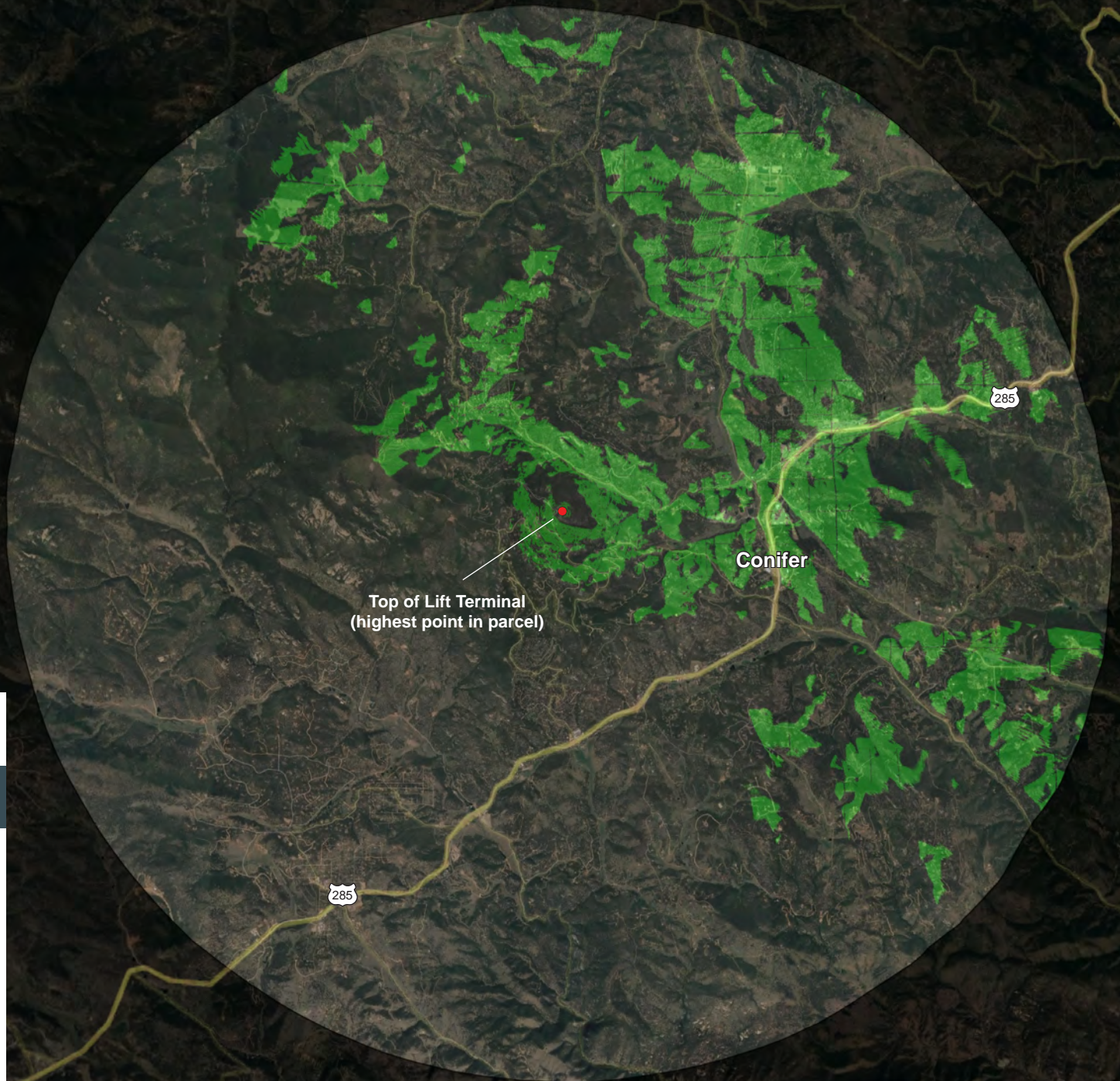

VISUAL ANALYSIS

Figure 5: Viewshed from top lift terminal

LEGEND

- Top lift terminal
- Viewshed areas

Notes:
Viewshed is shown within a 10km radius.
Viewshed calculations are approximate and do not account for vegetation and other obstructions.

Prepared by:



Scale
0 1 mi

WILDFIRE MITIGATION MANAGEMENT LEGEND:

- UNIT A - APPROX 7.5 AC MIXED CONIFER & PONDEROSA PINE
- UNIT B - APPROX 10.5 AC MIXED CONIFER & SPRUCE-FIR
- UNIT C - APPROX 14 AC MIXED CONIFER, SPRUCE-FIR, & PONDEROSA PINE
- UNIT D - APPROX 7.5 AC LODGEPOLE PINE, SOME FIR
- UNIT E - APPROX 12 AC MIXED CONIFER W/ ASPEN
- UNIT F - APPROX 5 AC MIXED CONIFER W/ ASPEN
- UNIT G - APPROX 3.5 AC MIXED CONIFER W/ ASPEN
- UNIT H - APPROX 1.25 MI ROAD

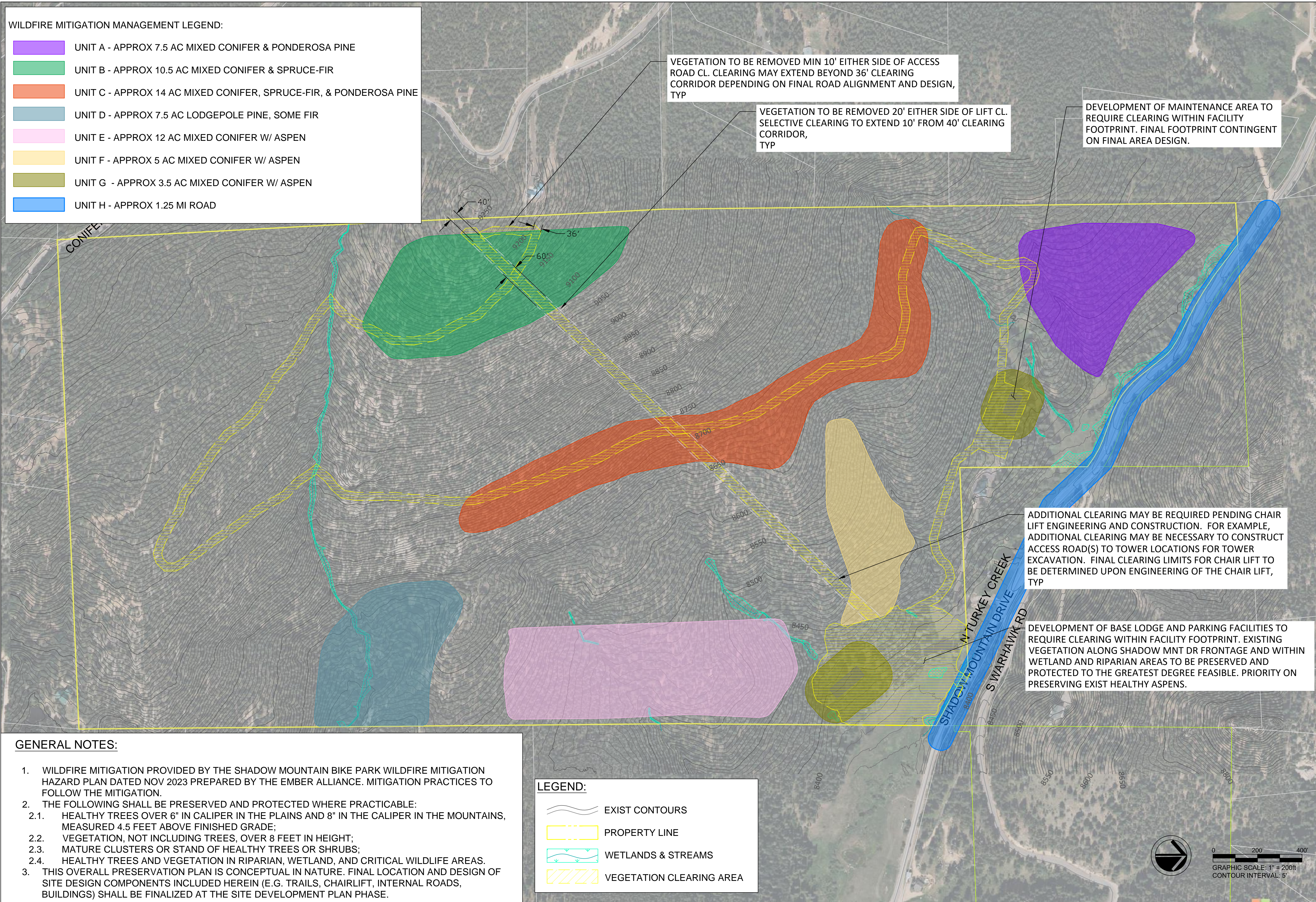

VEGETATION TO BE REMOVED MIN 10' EITHER SIDE OF ACCESS ROAD CL. CLEARING MAY EXTEND BEYOND 36' CLEARING CORRIDOR DEPENDING ON FINAL ROAD ALIGNMENT AND DESIGN, TYP

VEGETATION TO BE REMOVED 20' EITHER SIDE OF LIFT CL. SELECTIVE CLEARING TO EXTEND 10' FROM 40' CLEARING CORRIDOR, TYP

DEVELOPMENT OF MAINTENANCE AREA TO REQUIRE CLEARING WITHIN FACILITY FOOTPRINT. FINAL FOOTPRINT CONTINGENT ON FINAL AREA DESIGN.

ADDITIONAL CLEARING MAY BE REQUIRED PENDING CHAIR LIFT ENGINEERING AND CONSTRUCTION. FOR EXAMPLE, ADDITIONAL CLEARING MAY BE NECESSARY TO CONSTRUCT ACCESS ROAD(S) TO TOWER LOCATIONS FOR TOWER EXCAVATION. FINAL CLEARING LIMITS FOR CHAIR LIFT TO BE DETERMINED UPON ENGINEERING OF THE CHAIR LIFT, TYP

DEVELOPMENT OF BASE LODGE AND PARKING FACILITIES TO REQUIRE CLEARING WITHIN FACILITY FOOTPRINT. EXISTING VEGETATION ALONG SHADOW MNT DR FRONTAGE AND WITHIN WETLAND AND RIPARIAN AREAS TO BE PRESERVED AND PROTECTED TO THE GREATEST DEGREE FEASIBLE. PRIORITY ON PRESERVING EXIST HEALTHY ASPENS.

GENERAL NOTES:

1. WILDFIRE MITIGATION PROVIDED BY THE SHADOW MOUNTAIN BIKE PARK WILDFIRE MITIGATION HAZARD PLAN DATED NOV 2023 PREPARED BY THE EMBER ALLIANCE. MITIGATION PRACTICES TO FOLLOW THE MITIGATION.
2. THE FOLLOWING SHALL BE PRESERVED AND PROTECTED WHERE PRACTICABLE:
 - 2.1. HEALTHY TREES OVER 6" IN CALIPER IN THE PLAINS AND 8" IN THE CALIPER IN THE MOUNTAINS, MEASURED 4.5 FEET ABOVE FINISHED GRADE;
 - 2.2. VEGETATION, NOT INCLUDING TREES, OVER 8 FEET IN HEIGHT;
 - 2.3. MATURE CLUSTERS OR STAND OF HEALTHY TREES OR SHRUBS;
 - 2.4. HEALTHY TREES AND VEGETATION IN RIPARIAN, WETLAND, AND CRITICAL WILDLIFE AREAS.
3. THIS OVERALL PRESERVATION PLAN IS CONCEPTUAL IN NATURE. FINAL LOCATION AND DESIGN OF SITE DESIGN COMPONENTS INCLUDED HEREIN (E.G. TRAILS, CHAIRLIFT, INTERNAL ROADS, BUILDINGS) SHALL BE FINALIZED AT THE SITE DEVELOPMENT PLAN PHASE.

LEGEND:

- EXIST CONTOURS
- PROPERTY LINE
- WETLANDS & STREAMS
- VEGETATION CLEARING AREA

SHADOW MOUNTAIN BIKE PARK
CONIFER, COLORADO
Not For Construction

ISSUE
SCHEMATIC DESIGN

RELEASE DATE
December 23

REVISIONS

PROJECT NO. 22089001
MADE BY OD
REVIEWED BY AP

OVERALL VEGETATION PRESERVATION PLAN

VEG

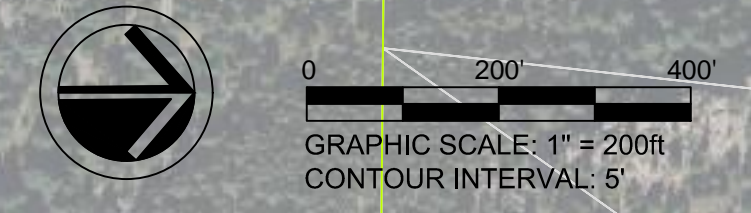



Shadow Mountain Bike Park Sensory Impact Assessment - Noise

Final Report

December 8, 2023

Prepared for:
SE Group
323 W Main St.
Frisco CO 80443

Prepared by:
Stantec Consulting Services Inc.
733 Marquette Avenue, Suite 1000
Minneapolis, MN 55402

Project Number:
195602713

Table of Contents

Table of Contents	i
Limitations and Sign-off	ii
Abbreviations	iii
Executive Summary	iv
1 Introduction	1
2 Noise Terminology	2
3 Facility Description	3
4 Noise Sources	4
5 Noise Sensitive Areas	5
6 Assessment Criteria	6
7 Methodology	7
7.1 Operational Noise Analysis.....	7
7.2 Construction Noise Assessment.....	8
7.2.1 Construction Noise Mitigation.....	9
8 Operational Noise Assessment	10
9 Conclusion	12

List of Tables

Table 5.1: Noise Sensitive Location Summary.....	5
Table 6.1: Jefferson County LDR Noise Criteria ¹	6
Table 7.1: Equipment Sound Power Levels.....	7
Table 7.2: Modelling Assumption Summary.....	7
Table 7.3: Construction Noise Limits.....	8
Table 7.4: Construction Equipment Noise Levels ¹	9
Table 8.1: Noise Impact Summary Table – LA _{eq} Stationary Noise Sources.....	10
Table 8.2: Noise Impact Summary Table - LA _{max} Mobile Noise Sources.....	11

List of Agencies

Appendix A Figures

Figure A.1	Site Location Map
Figure A.2	NSA MAP
Figure A.3	Zoning Map
Figure A.4	Daytime Noise Contours LA _{eq} 4.5 m AG (15 ft. aG)
Figure A.5	Nighttime Noise Contours LA _{eq} 4.5 m AG (15 Ft. Ag)
Figure A.6	Daytime Noise Contours L _{max} 4.5 M AG



Limitations and Sign-off

The conclusions in this report Titled Shadow Mountain Bike Park Sensory Impact Assessment – Noise, are Stantec’s professional opinion, as of the time of the Report, and concerning the scope described in the Report. The opinions in the document are based on conditions and information existing at the time the scope of work was conducted and do not take into account any subsequent changes. The Report relates solely to the specific project for which Stantec was retained and the stated purpose for which the Report was prepared. The Report is not to be used or relied on for any variation or extension of the project, or for any other project or purpose, and any unauthorized use or reliance is at the recipient’s own risk.

Stantec has assumed all information received from SE Group (the “Client”) and third parties in the preparation of the Report to be correct. While Stantec has exercised a customary level of judgment or due diligence in the use of such information, Stantec assumes no responsibility for the consequences of any error or omission contained therein.

This Report is intended solely for use by the Client in accordance with Stantec’s contract with the Client. While the Report may be provided to applicable authorities having jurisdiction and others for whom the Client is responsible, Stantec does not warrant the services to any third party. The report may not be relied upon by any other party without the express written consent of Stantec, which may be withheld at Stantec’s discretion.

Prepared by: _____
Signature
Samuel Arnold, P.Eng., MAsc.
Acoustical Engineer

Printed Name and Title

Reviewed by:  _____
Signature
Jacob Poling, INCE
Senior Acoustician

Printed Name and Title

Approved by: _____
Signature
JoAnne Blank
Senior Associate Scientist

Printed Name and Title



Abbreviations

dB	Decibel
dBA	Decibel (A-weighted)
GA	Ground absorption
Hz	Hertz
ISO	International Standards Organization
L_{eq}	Equivalent continuous sound level
L_0	Sound level exceeded for 0% of the time
L_{10}	Sound level exceeded for 10% of the time
L_{25}	Sound level exceeded for 25% of the time
L_{50}	Sound level exceeded for 50% of the time
L_{90}	Sound level exceeded for 90% of the time
L_{max}	Maximum sound level
L_{min}	Minimum sound level
LDR	Land Development Regulations
SIA	Sensory Impact Assessment
SLM	Sound level meter
SMBP	Shadow Mountain Bike Park



Executive Summary

The SE Group has retained Stantec Consulting Services Inc. (Stantec) to complete a Sensory Impact Assessment (SIA) to evaluate noise impacts generated by the proposed Shadow Mountain Bike Park (SMBP). The proposed location of the SMBP is along Shadow Mountain Drive in Conifer, Jefferson County, Colorado (the Site). The proposed SMBP will consist of a downhill mountain bike park with lift services, 320 parking spaces, a day lodge building, and a maintenance building.

This SIA was completed in accordance with the requirements of the Jefferson County Colorado Land Development Regulation (LDR), amended December 6, 2022, which requires that proposed Developments not create sensory impacts including noise, odor, and visual impacts at nearby sensitive receptors such as parks, schools, or residential buildings. The scope of this SIA is limited to the evaluation of the impacts of noise resulting from the operation of the proposed SMBP only.

Operational noise from the SMBP was modelled using CADNA/A acoustic modelling software (version 2021 MR2) published by Datakustik GmbH, configured to implement ISO-9613-2 environmental noise propagation algorithms. Operational noise sources from Stantec's database were used for this assessment as final equipment selections and final design of the SMBP have yet to be completed at the time of writing of this report.

Stantec recommends that this study be updated when final design of the SMBP is complete to validate the assumptions of this SIA.

Predicted sound levels indicate that the noise generated by the proposed SMBP at nearby noise sensitive areas and highest impacted/worst case property line locations is below the applicable daytime and nighttime noise limits for nearby residential receptors. The results of this SIA demonstrate that the SMBP is expected to comply with the Jefferson County LDR noise limits.



1 Introduction

The SE Group has retained Stantec Consulting Services Inc. (Stantec) to complete a Sensory Impact Assessment (SIA) to evaluate noise impacts generated by the Shadow Mountain Bike Park (SMBP). The proposed location of the SMBP is along Shadow Mountain Drive in Conifer, Jefferson County, Colorado (The Site). The proposed SMBP will consist of a downhill mountain bike park with lift services, 320 parking spaces, a day lodge building, and a maintenance building.

This SIA was prepared in accordance with Section 26 of the Jefferson County Land Development Regulations (LDR) amended December 6, 2022.

Figure A.1 included in **Appendix A** shows the location of the Site.



2 Noise Terminology

Sound is caused by vibrations that generate waves of minute pressure fluctuations in the surrounding air. Sound levels are measured using a logarithmic decibel (dB) scale. Human hearing varies in sensitivity for different sound frequencies, and the frequency sensitivity changes based on the overall sound level. The ear is most sensitive to sound at frequencies between 800 and 8,000 hertz (Hz) and is least sensitive to sound at frequencies below 400 Hz or above 12,500 Hz. Consequently, several different frequency weighting schemes have been used to approximate the way the human ear responds to various frequencies at different sound levels. The A-weighted decibel, or dBA, scale is the most widely used for regulatory requirements, as it discriminates against low frequency noise similar to the response of the human ear at the low to moderate sound levels typical of environmental sources. Sound levels without a frequency weighting applied, referred to as unweighted or linear, are generally reported as dB or dBZ.

The sound power level (PWL or L_w) of a noise source is the strength or intensity of noise that the source emits regardless of the environment in which it is placed. Sound power is a property of the source, and therefore is independent of distance. The radiating sound power then produces a sound pressure level (SPL or L_p) at a point of which human beings can perceive as audible sound. The sound pressure level is dependent on the acoustical environment (e.g., indoor, outdoor, absorption, reflections) and the distance from the noise source. Unless otherwise stated, sound levels in this report are sound pressure levels.

Numerous metrics and indices have been developed to quantify the temporal characteristics (changes over time) of community noise. The equivalent continuous sound level, L_{eq} , metric is the level of a hypothetical steady sound that would have the same energy as the fluctuating sound level over a defined period of time. The L_{eq} represents the time average of the fluctuating sound pressure level. The maximum and minimum sound levels, or L_{max} and L_{min} , are the loudest and quietest instantaneous sound levels occurring during a period of time. The L_{max} is particularly useful for evaluating loud, impulsive noise events.

Other statistical metrics useful to understanding environmental sound levels include the n-percent exceedance sound percentile levels, or L_n . This report includes the L_{25} metric, or the noise level that is exceeded 25% of the time and the L_0 which is the sound level exceeded 0% of the time. The L_0 can be considered equivalent to the L_{max} or maximum sound level. The L_{10} can be approximated as the sound level between L_{max} and L_{25} .

A change in sound levels of 3 decibels is generally considered to be the threshold of perception, whereas a change of 5 decibels is clearly perceptible, and a change of 10 decibels is perceived as a doubling or halving of loudness.



3 Facility Description

The proposed SMBP will consist of a four-passenger chairlift to transport guests and bikes to the top terminal area for gravity flow and downhill trails. The SMBP will operate during daytime hours, as defined by Section 26 of the Jefferson County LDR, between 7 a.m. to 7 p.m. The chairlift will require one terminal in the base area and the terminal area at the top of Shadow Mountain. Chairlift construction will require a 40-foot-wide corridor to accommodate the associated infrastructure. The corridor will be cleared during the construction phase of the project. The chairlift will require power at the bottom and top terminal areas as well as communication lines along the lift infrastructure.

The SMBP will provide approximately 16 miles of trails with varying levels of difficulty. Trails will be constructed of earth, wood, steel, and other materials. All trails will be setback a minimum of 50 feet from property lines.

Parking for approximately 300 guest vehicles will be provided near the base area using the access road along Shadow Mountain Drive. A day lodge will be constructed in the base area of the SMBP to provide guest services including indoor seating, ticketing, restrooms, changing rooms, bike and equipment rentals, and outdoor guest space and seating. Water will be supplied by a commercial water well and sewage will be handled by an onsite wastewater system.

There will be no permanent kitchen space in the day lodge. To address the food and beverage needs of guests, food truck vendors will be brought on site during operational hours.

A maintenance building will be constructed along the maintenance access road for facility operations. Parking for approximately 20 employees will be provided adjacent to the maintenance building.



4 Noise Sources

Based on the facility description, the primary sources of noise from the SMBP are assumed to be the following:

- Chairlift terminals at the base area and top of Shadow mountain.
- HVAC equipment at the day lodge, maintenance building, and chairlift buildings.
- Vehicle noise from movements in the parking lot.
- Vehicle noise along the maintenance road from the maintenance shop to the mountain top.
- Speakers near the day lodge outside dining area.
- A food truck idling adjacent to the day lodge.

The primary noise sources expected to operate at the proposed SMBP are consistent with the definition of steady state or quasi steady state impulsive sound. Steady state or quasi steady state impulsive sound can generally be defined as a sequence of impulsive sound emitted from the same source having a time interval of less than 0.5 seconds between successive impulsive sounds. Impulsive sound can be generally defined as a single pressure pulse or a single burst of pressure pulses with a time interval of equal or greater than 0.5 seconds. Examples of impulsive sound can include dump truck gate banging or impact pile driver operation.

Other potential sources of noise on site such as human or electric powered mountain bikes travelling along the proposed SMBP trails or noise along the chairlift line are assumed to have an insignificant impact to nearby sensitive noise receptors.



5 Noise Sensitive Areas

Noise sensitive areas (NSAs) were identified around the SMBP based on a review of satellite imagery and zoning. Thirteen NSA locations were selected to evaluate the noise impact from steady state noise SMBP sources at residences. Five (5) additional locations were selected near the property lines of the Site as representative worst-case locations. Property line locations were assessed 25 feet from the property limits of the proposed SMBP consistent with the evaluation requirements of the Jefferson County LDR. A summary of NSAs is provided in **Table 5.1**. A location map of NSAs is included as **Figure A.2** in **Appendix A**. A zoning map for the area surrounding the site is included as **Figure A.3** in **Appendix A**.

Table 5.1: Noise Sensitive Location Summary

Noise Sensitive Area ID	Description and Approximate Street Address ¹	UTM NAD 83 Coordinates		
		Zone	Easting	Northing
NSA01	Residence at 30812 Shadow Mountain Drive	13S	469462	4376303
NSA02	Residence at 10188 Christopher Drive	13S	469795	4375463
NSA03	Residence at 10178 Christopher Drive	13S	469781	4375299
NSA04	Residence at 10218 Christopher Drive	13S	469621	4375781
NSA05	Residence at 29795 Kennedy Gulch Road	13S	470473	4374826
NSA06	Residence at 30241 Shadow Mountain Drive	13S	470491	4376172
NSA07	Residence at 29611 Shadow Mountain Drive	13S	470742	4375981
NSA08	Residence at 29365 Kennedy Gulch Road	13S	471070	4375165
NSA09	Residence at 30772 Shadow Mountain Drive	13S	469711	4376453
NSA10	Residence at 30192 Shadow Mountain Drive	13S	470205	4376076
NSA11	Residence at 29455 Kennedy Gulch Road	13S	470684	4374893
NSA12	Residence at 29405 Kennedy Gulch Road	13S	470988	4374980
NSA13	Residence at 29152 Shadow Mountain Drive	13S	471269	4375568
NSA14	25 ft. from West Property Line	13S	469810	4375391
NSA15	25 ft. from North Property Line	13S	470170	4376056
NSA16	25 ft. from North East Property Line	13S	470456	4376057
NSA17	25 ft. from East Property Line	13S	470525	4375820
NSA18	25 ft. from East Property Line	13S	470523	4375937

¹ All residences conservatively assumed to be two-story residences.



6 Assessment Criteria

The December 6, 2022, revision of the Jefferson County, Colorado LDR regulates the development of lands in the County with consideration given to protecting land, environment, and natural resources. Section 26 of the LDR regulates sensory impacts from a Development which can include noise, odor, and visual impacts. This assessment is limited to assessing the noise impact of the proposed SMBP.

The applicable criteria for the project under Section 4, Subsection A is:

“Noise generated from the proposed development shall not exceed the dBA levels set forth in Section 25-12-103, C.R.S. or as may be amended from time to time. The dBA levels are depicted in the dBA Table: (reloc. 7-12-05; am. 4-4-06)”

The table referenced in the LDR is provided as **Table 6.1**.

Table 6.1: Jefferson County LDR Noise Criteria¹

dBA Table					
Time	7 a.m. to 7 p.m.	7 a.m. to 7 p.m.	7 a.m. to 7 p.m.	7 p.m. to 7 a.m.	7 p.m. to 7 a.m.
Frequency	L ₂₅	L ₀	Periodic/Impulsive	L ₀	Periodic/Impulsive
Park/School, Residential	55	65	50	50	45
Commercial	60	70	55	55	50
Light Industrial	70	80	65	65	60
Industrial	80	90	75	75	70

¹ Source Jefferson County Colorado Land Development Regulation December 2022

The area surrounding the proposed SMBP is zoned primarily residential or agricultural with existing residences. Stantec has adopted the steady state (i.e., non-periodic/impulsive) noise limits for residential areas and property line evaluation locations for this assessment. The applicable limits for residential areas are L₂₅ of 55 dBA or L₀ of 65 dBA during daytime hours and L₀ of 50 dBA during nighttime hours for steady state noise sources measured 25 ft. from the property limits of the SMBP

The SMBP is not expected to have any significant sources of periodic or impulsive noise and operations will be limited to daytime hours only, with the exception of HVAC units. The L₁₀ noise level of a noise source can typically be estimated by adding 3 dBA to the LA_{eq} noise level¹ and, by definition, the L₂₅ noise level for a piece of equipment will be lower than the L₁₀ noise level. For this study, the L₂₅ noise level was conservatively estimated by adding a 3 dBA correction factor to modelled LA_{eq} noise levels. The L₀ noise level, which is higher than both the L₁₀ and L₂₅, was conservatively estimated by adding a 6 dBA correction factor to modelled LA_{eq} noise levels. After accounting for these adjustment factors, the applicable LA_{eq} noise limits for this assessment are 59 dBA (65 dBA L₀ - 6 dB) during daytime hours and 44 dBA (50 dBA L₀ - 6 dB) during nighttime hours for residential receptors.

¹ Federal Highway Administration Roadway Construction Noise Model (RCNM) User's Guide. January 2006.



7 Methodology

7.1 Operational Noise Analysis

The proposed SMBP will include several sources of steady state noise as described in **Section 4**. As final equipment selections have not been completed at the time of writing of this report, Stantec has selected representative sound power levels to model the predicted impact of the SMBP.

The representative equipment sound power levels used in the analysis are summarized in **Table 7.1**.

Table 7.1: Equipment Sound Power Levels

Equipment Type	Type	Octave Band Sound Power Level (dB)									Total Sound Power Level (dBA)
		31.5 Hz	63 Hz	125 Hz	250 Hz	500 Hz	1,000 Hz	2,000 Hz	4,000 Hz	8,000 Hz	
Chair Lift Terminal	Leq	73	78	93	90	93	88	96	83	78	98
Vehicle Passby	Lmax	64	59	65	58	55	54	50	45	40	90
HVAC Unit	Leq	85	86	82	78	76	73	69	64	56	78
Truck Idle	Leq	30	94	96	94	88	85	81	78	74	91
Speaker	Leq	86	93	91	86	90	95	91	87	81	98

Table 7.2 summarizes the modelling assumptions used for equipment quantities, operating parameters including speed and operating time, and other modelling parameters.

Table 7.2: Modelling Assumption Summary

Equipment Type	Quantity	Operation Time	Operational Notes
Chair Lift Terminal	2	7 a.m. to 7 p.m.	Operations at the top terminal area and at the base terminal area. Operating continuously during daytime hours only.
Transport Truck	1	7 a.m. to 7 p.m.	One truck per hour along the maintenance road connecting the top terminal to the maintenance building. Speed assumed to be 10 mph and operating during daytime hours only.
HVAC Unit	6	24-hour operation	One HVAC unit at the top terminal chairlift, one at the bottom terminal chairlift, two at the day lodge building, and two at the maintenance building. All operating continuously over a 24-hour period
Truck Idle	1	7 a.m. to 7 p.m.	One food trucks idling along the southwest side of the lodge building operating continuously during daytime hours only.
Speaker	1	7 a.m. to 7 p.m.	One speaker adjacent to the outdoor seating area at the southwest side of the lodge building operating continuously during daytime hours only
Vehicle Parking Noise	241	7 a.m. to 7 p.m.	A worst case 241 vehicles per hour entering and exiting the site in the parking lot area has been assumed.



Noise modeling was completed using the Datakustik CadnaA environmental noise modeling software. The operational noise modeling followed typical modeling standards, input parameters, and assumptions, namely:

- The ISO 9613-2 standard² algorithm for outdoor sound propagation was used.
- Ground absorption factor of G=0.8 was used.
- Ground elevations were included in the model using equal height contour lines.
- Meteorology parameters were set to 10 degrees Celsius and 70 percent relative humidity.
- Receptor height of 4.5 m (15 ft.) to be representative of a two-storey residence.
- No sound attenuation from vegetation (foliage) to simulate a worst-case condition when leaves have fallen off trees.
- Meteorological conditions are conducive to sound propagation with all receptors located downwind of all noise sources.

7.2 Construction Noise Assessment

Construction activities related to the Development of the proposed SMBP will occur in phases and generally consist of site preparation including tree clearing and road construction, installation of the chair lift, construction of the lodge, and installation of utilities. Construction activities will typically be limited to daytime only.

In accordance with the Jefferson County Regulatory Policy – Noise Abatement adopted April 24, 2007 (*“Policy No. Part 3, Regulations, Chapter 1, Noise, Section 1”*) construction activities are subject to the noise limits summarized in **Table 7.3**.

Table 7.3: Construction Noise Limits

Time Period	Limits ¹
7 a.m. to 7 p.m.	80 dB(A)
7 p.m. to 7 a.m.	75 dB(A)

¹ Noise limits are applicable 25 ft. from the property line of the Development.

At this stage of the proposed SMBP development, detailed construction phasing including equipment selections and timelines have not been finalized. In general, noise impacts from construction equipment will vary by type, age of equipment, overall condition, and operators. During construction of the proposed SMBP, noise from construction activities may be audible at nearby sensitive receptors; however, not all construction equipment required for the construction of the SMBP will be operating at the same time. Additionally, activities will be spread across the Project area and be temporary in duration which will reduce the overall noise impact of construction activities.

² ISO 9613-2: 1996. Acoustics – Attenuation of sound during propagation outdoors. Part 2: General method of calculation.



The minimum setback distance of noise sensitive areas identified in **Section 5** is approximately 200 feet from major project components such as the chairlift, parking lot, and day lodge. A summary of representative noise levels for anticipated construction equipment is provided in Table 7.4 at 50 ft. Maximum sound levels from equipment is expected to below the applicable construction noise limits identified in **Table 7.3**; however, Stantec recommends that the construction equipment list and setback distances be reviewed and confirmed prior to construction.

Table 7.4: Construction Equipment Noise Levels¹

Equipment	Noise Level at 50 feet from Source (dBA L _{max})	Noise Level at 200 feet from Source (dBA L _{max})
Bulldozer	85	73
Crane	85	73
Chainsaw	85	73
Excavator	81	69
Front end loader	79	67
Concrete batch plant	83	71
Drill Rig Truck	79	67
Grader	85	73
Haul/Dump Truck	84	72
Flat Bed Truck	74	62
Pneumatic Tools	85	73
Backhoe	80	68

¹ Source: Federal Highway Administration Roadway Construction Noise Model (RCNM) User's Guide. January 2006.

7.2.1 Construction Noise Mitigation

Construction noise is typically mitigated by implementing best practices such as ensuring construction equipment and associated mufflers are in good working order, limiting the loudest construction activities to daytime hours, using alternative quieter construction methods and/or scheduling work to minimize concurrent use of the loudest equipment, and establishing a noise complaint resolution process. Placement of noise barriers around work sites can be considered for activities in the near vicinity of noise-sensitive land uses.



8 Operational Noise Assessment

Operational noise modelling was completed for the proposed SMBP with the modelling assumptions and methodology outlined in **Section 7.1**. With the exception of HVAC equipment, on-site noise sources will operate during daytime hours only. Due to the varying nature of vehicle passbys as they travel along a modelled path, Stantec has conservatively evaluated vehicle passbys using an L_0 or L_{max} assessment. As all other sources of noise are stationary, they have been evaluated using an LA_{eq} assessment.

Predicted project-generated noise levels at the noise sensitive areas and property lines are summarized in **Table 8.1** for LA_{eq} stationary noise sources. Predicted project-generated noise levels at the noise sensitive areas and representative property line locations are summarized in **Table 8.2** for LA_{max} mobile noise sources. Mobile noise source impacts are as a result of vehicle passbys along the maintenance road and parking lot. The L_{max} is the maximum noise level resulting from a vehicle passby rather than the equivalent energy sound level LA_{eq} .

Table 8.1: Noise Impact Summary Table – LA_{eq} Stationary Noise Sources

Noise Sensitive Area ID	Description	Daytime Project Noise Level (dBA) ¹	Nighttime Project Noise Level (dBA) ¹	Day Limit (dBA) ²	Night Limit (dBA) ²	Complies with Limits?
NSA01	Residence at 30812 Shadow Mountain Drive	22	11	59	44	Yes
NSA02	Residence at 10188 Christopher Drive	48	30	59	44	Yes
NSA03	Residence at 10178 Christopher Drive	39	23	59	44	Yes
NSA04	Residence at 10218 Christopher Drive	30	18	59	44	Yes
NSA05	Residence at 29795 Kennedy Gulch Road	19	9	59	44	Yes
NSA06	Residence at 30241 Shadow Mountain Drive	43	25	59	44	Yes
NSA07	Residence at 29611 Shadow Mountain Drive	38	21	59	44	Yes
NSA08	Residence at 29365 Kennedy Gulch Road	24	10	59	44	Yes
NSA09	Residence at 30772 Shadow Mountain Drive	28	18	59	44	Yes
NSA10	Residence at 30192 Shadow Mountain Drive	42	31	59	44	Yes
NSA11	Residence at 29455 Kennedy Gulch Road	25	13	59	44	Yes
NSA12	Residence at 29405 Kennedy Gulch Road	23	11	59	44	Yes
NSA13	Residence at 29152 Shadow Mountain Drive	28	13	59	44	Yes
NSA14	25 ft. from West Property Line	56	38	59	44	Yes
NSA15	25 ft. from North Property Line	42	34	59	44	Yes
NSA16	25 ft. from North East Property Line	56	31	59	44	Yes
NSA17	25 ft. from East Property Line	48	30	59	44	Yes
NSA18	25 ft. from East Property Line	53	30	59	44	Yes

¹ Project noise levels presented as LA_{eq} values.

² Day and night noise limits are presented as LA_{eq} values, converted from L_0 criteria using a 6 dBA correction factor as described in Section 0.



Shadow Mountain Bike Park Sensory Impact Assessment - Noise

8 Operational Noise Assessment

December 8, 2023

Table 8.2: Noise Impact Summary Table - LA_{max} Mobile Noise Sources

Noise Sensitive Area ID	Description	Daytime Project Noise Level (dBA) ¹	Nighttime Project Noise Level (dBA) ¹	Day Limit (dBA) ²	Night Limit (dBA) ²	Complies with Limits?
NSA01	Residence at 30812 Shadow Mountain Drive	20	-	65	50	Yes
NSA02	Residence at 10188 Christopher Drive	49	-	65	50	Yes
NSA03	Residence at 10178 Christopher Drive	39	-	65	50	Yes
NSA04	Residence at 10218 Christopher Drive	28	-	65	50	Yes
NSA05	Residence at 29795 Kennedy Gulch Road	27	-	65	50	Yes
NSA06	Residence at 30241 Shadow Mountain Drive	35	-	65	50	Yes
NSA07	Residence at 29611 Shadow Mountain Drive	31	-	65	50	Yes
NSA08	Residence at 29365 Kennedy Gulch Road	19	-	65	50	Yes
NSA09	Residence at 30772 Shadow Mountain Drive	27	-	65	50	Yes
NSA10	Residence at 30192 Shadow Mountain Drive	46	-	65	50	Yes
NSA11	Residence at 29455 Kennedy Gulch Road	26	-	65	50	Yes
NSA12	Residence at 29405 Kennedy Gulch Road	20	-	65	50	Yes
NSA13	Residence at 29152 Shadow Mountain Drive	20	-	65	50	Yes
NSA14	25 ft. from West Property Line	56	-	65	50	Yes
NSA15	25 ft. from North Property Line	56	-	65	50	Yes
NSA16	25 ft. from North East Property Line	64	-	65	50	Yes
NSA17	25 ft. from East Property Line	39	-	65	50	Yes
NSA18	25 ft. from East Property Line	55	-	65	50	Yes

¹ Project noise levels presented as LA_{max} values.

² Day and night noise limits are presented as LA_{eq} values, converted from L₀ criteria using a 6 dBA correction factor as described in Section 0.

Project sound levels are predicted to be below the applicable daytime and nighttime noise criteria at nearby sensitive receptors and 25 feet from the property line of the SMBP. Sound level contours at 15 feet above ground are presented in **Figure A.4** and **Figure A.5** for LA_{eq} noise impacts and **Figure A.6** for L_{max} impacts from vehicle passbys in **Appendix A**. The sound level contours illustrate how sound is expected to propagate in the area surrounding the Project and account for the effects of local site topography. The sound level contours show the noise impact is below the applicable limits at nearby receptors and at locations 25 feet from the property line of the proposed SMBP.



9 Conclusion

This sensory impact assessment was completed to evaluate the noise impact of the proposed Shadow Mountain Bike Park the Jefferson County Land Development Regulations. An operational noise model was developed and used to predict the noise impacts of proposed equipment on the Site.

The results of the noise modelling for operational noise predict that noise levels at the nearby sensitive noise receivers will comply with the Jefferson County requirements.

Additionally, construction noise impacts from equipment predicted to be required for the construction of the Shadow Mountain Bike Park are expected to be below the applicable construction noise limits.

This assessment was completed using the preliminary site layout and equipment locations provided by the SE group. Locations of equipment and equipment selection may change and additional construction equipment, not considered in this assessment, such as impact pile drivers may be required during construction. Stantec recommends that this study be updated when final design is completed to evaluate compliance with applicable noise criteria and validate the assumptions made for this assessment.



Appendices



Appendix A Figures



\\va004-dpfiles\work_group\01609\active_Other_POC_Active\009_GIS\181711248\03_data\figs\emr\noise\report_figures\noise_181711248_noise_is_spr\181711248_fig01_SitePlan_Reviewed: 2023-11-30 By: malcazaran

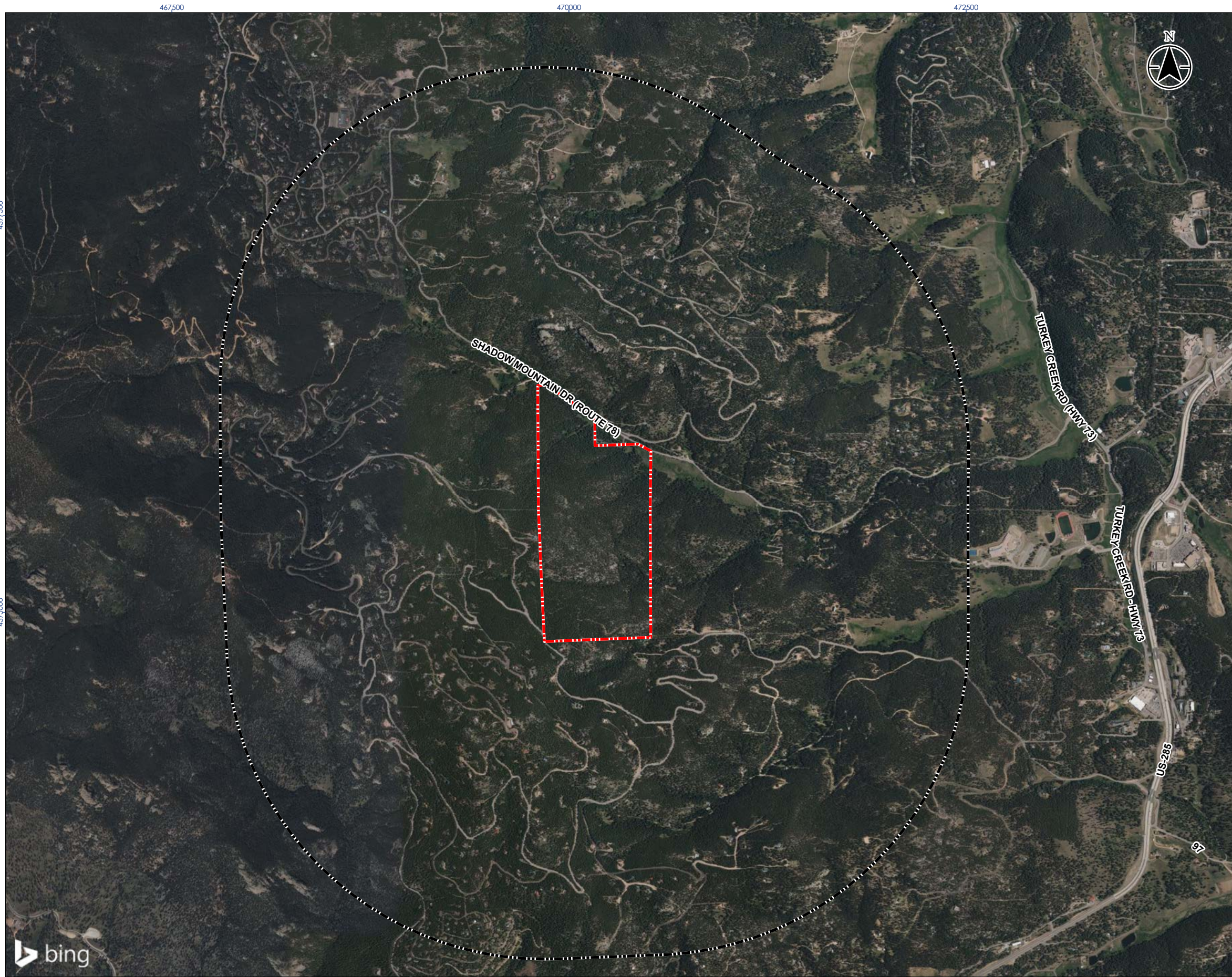

Legend

- Site Limits
- Site Limits (2km buffer)

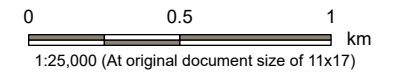

- Notes**
1. Coordinate System: NAD 1983 UTM Zone 13N
 2. Base features produced under creative commons license with the Colorado Department of Transportation © 2022.
 3. Orthoimagery © 2023 Microsoft Corporation © 2023 Maxar © CNES (2023) Distribution Airbus DS

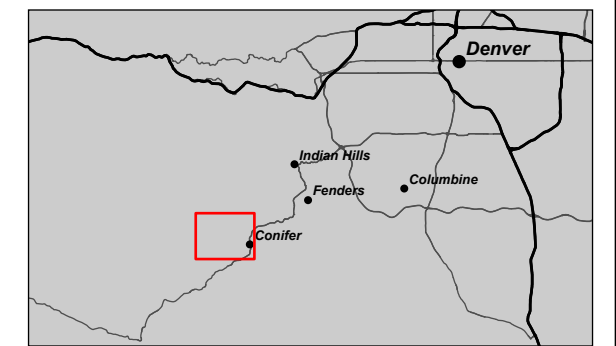

Project Location: 181711248 REVA
 Jefferson County, CO Prepared by MDA on 2023-11-30
 Technical Review by BCC on 2023-11-30

Client/Project:
 SE Group
 Shadow Mountain Sensory Impact Study - Noise

Figure No.

A.1

Title

Site Plan





470000

471000



Legend

-  Site Limits
-  Noise Receptor

470000

471000

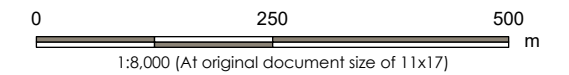
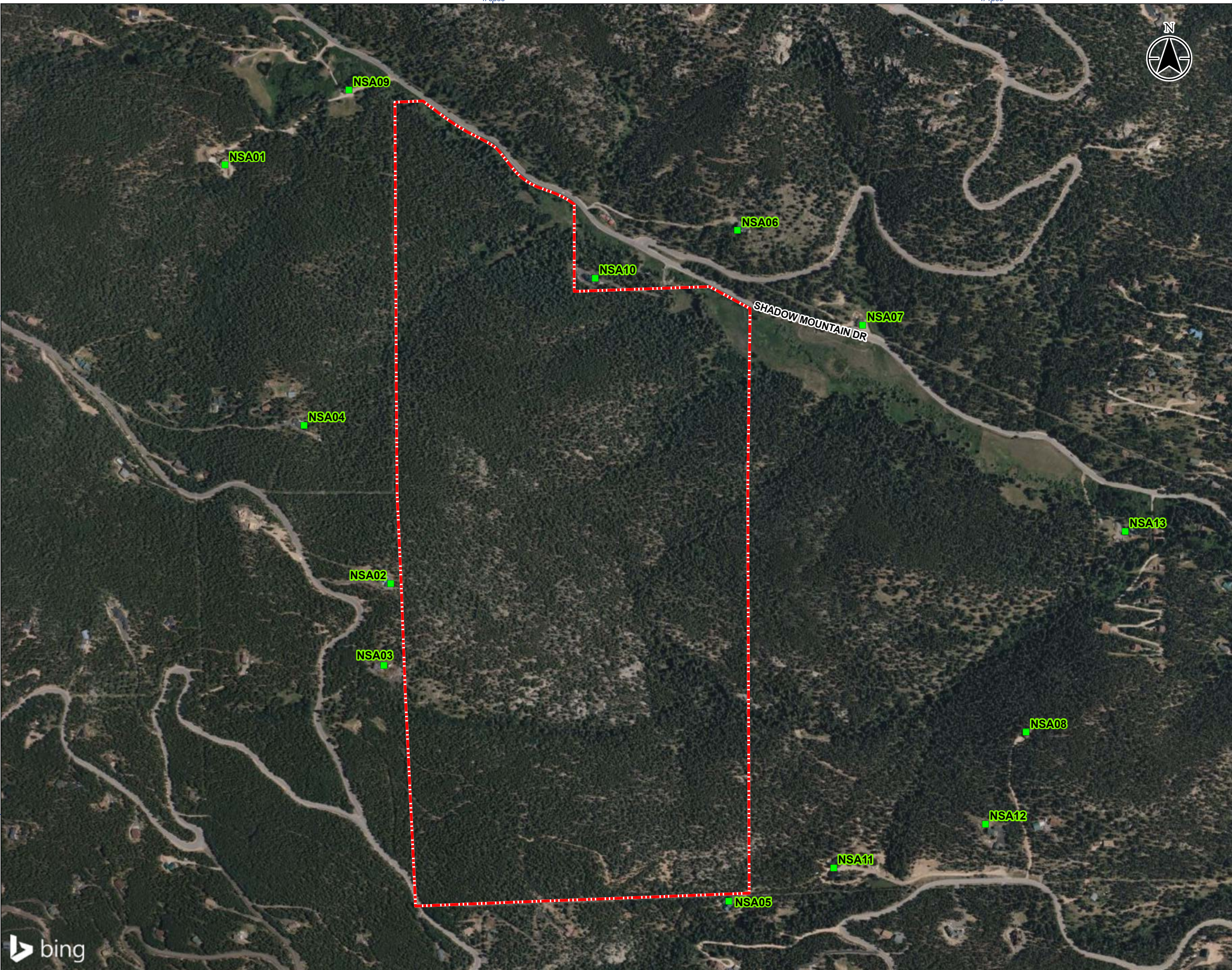

- Notes**
1. Coordinate System: NAD 1983 UTM Zone 13N
 2. Base features produced under creative commons license with the Colorado Department of Transportation © 2022.
 3. Orthoimagery © 2023 Microsoft Corporation © 2023 Maxar © CNES (2023) Distribution Airbus DS

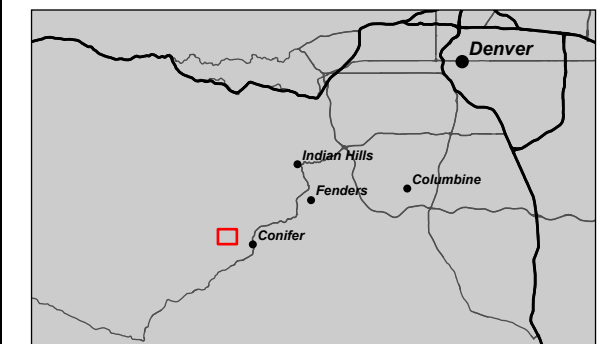

Project Location: 181711248 REVA
 Jefferson County, CO Prepared by MDA on 2023-11-30
 Technical Review by BCC on 2023-11-30

Client/Project:
 SE Group
 Shadow Mountain Sensory Impact Study - Noise

Figure No.
A.2
 Title
Noise Source Plan



\va0004-ppes\work_group\01609\active_Other_POC_Active\009_GIS\181711248\03_data\gis_cad\gis\mxd\noise\report_figures\noise_181711248_noise_181711248_fig02_NSPan_Review_2023-11-30_By_malcacaren

4375000

4375000

4375000





4375000

470000

471000



Legend

-  Site Limit
-  Noise Receptor
-  Point Source
-  Line Source
-  Daytime Noise Contour 4.5m (15ft.) AG

4376000

4375000

4375000

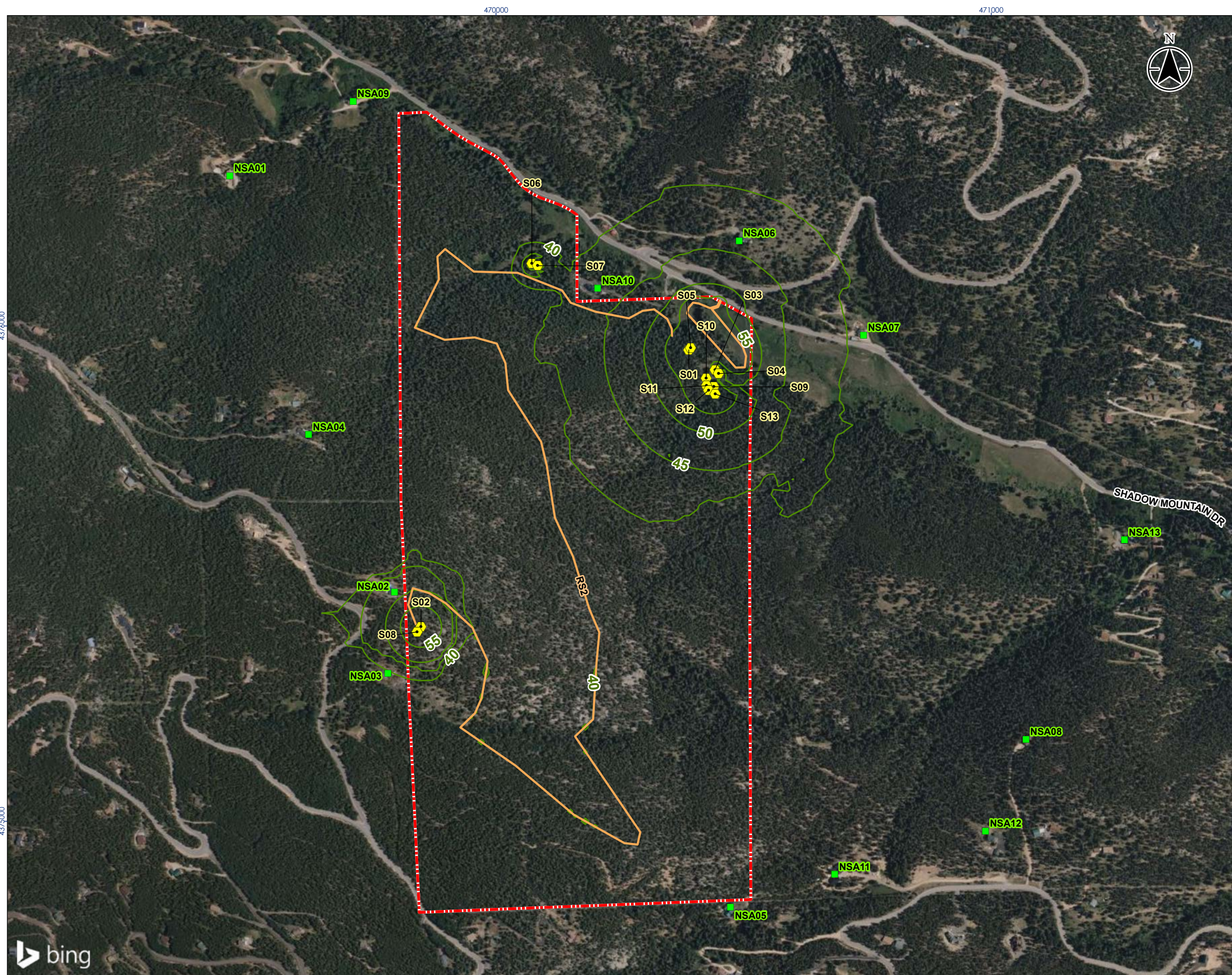

4376000

4375000

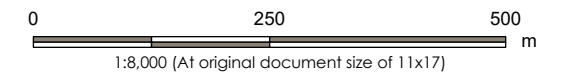

- Notes**
1. Coordinate System: NAD 1983 UTM Zone 13N
 2. Base features produced under creative commons license with the Colorado Department of Transportation © 2022.
 3. Orthoimagery © 2023 Microsoft Corporation © 2023 Maxar © CNES (2023) Distribution Airbus DS

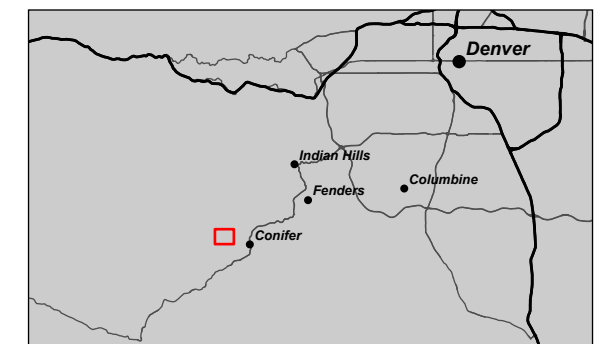

Project Location: Jefferson County, CO
 Prepared by MDA on 2023-11-30
 Technical Review by BCC on 2023-11-30

Client/Project: SE Group
 Shadow Mountain Sensory Impact Study - Noise

Figure No.: **A.4**
 Title: **Daytime Noise Contour 4.5m (15 ft.) AG**

470000

471000

\\va004-prd-s01\work_group\01609\active_Other_POC_Active\009_GIS\181711248\03_data\gis_cad\gis\mxd\noise\report_figures\noise_181711248_noise_is_spr\181711248_fig05_nightime Revised: 2023-11-30 By: malcazaren

4375000

4375000

470000





471000

470000

471000



Legend

-  Site Limit
-  Noise Receptor
-  Point Source
-  Line Source
-  Nighttime Noise Contour 4.5m (15 ft.) AG

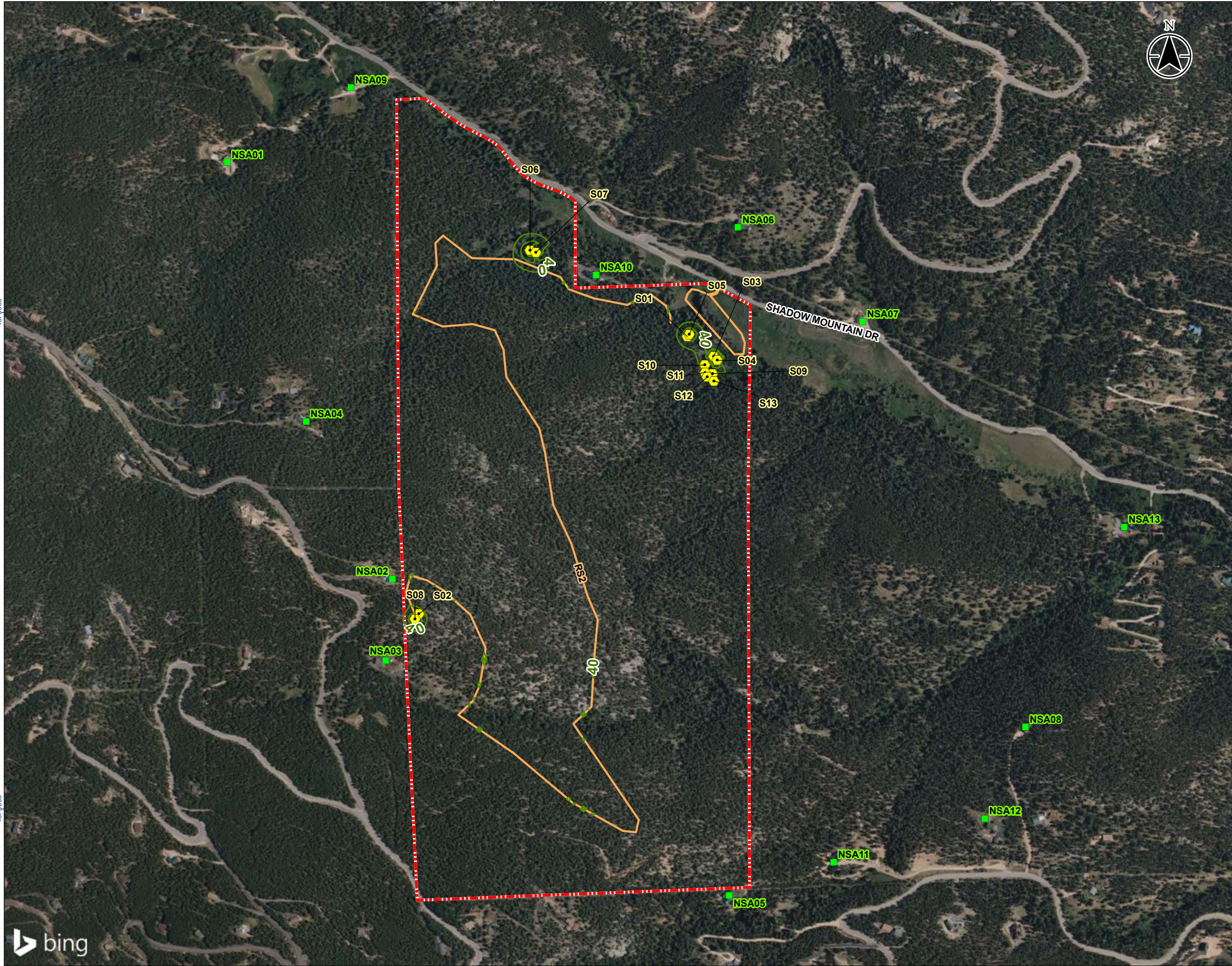

4375000

4375000

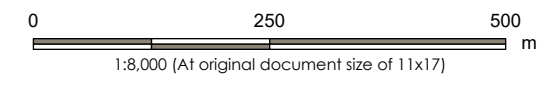

- Notes**
1. Coordinate System: NAD 1983 UTM Zone 13N
 2. Base features produced under creative commons license with the Colorado Department of Transportation © 2022.
 3. Orthoimagery © 2023 Microsoft Corporation © 2023 Maxar © CNES (2023) Distribution Airbus DS

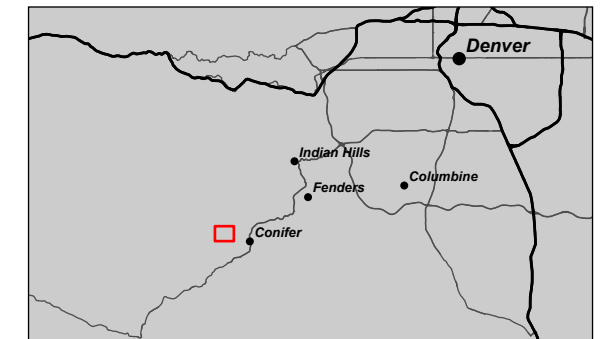

Project Location: Jefferson County, CO
 Prepared by MDA on 2023-11-30
 Technical Review by BCC on 2023-11-30

Client/Project: SE Group
 Shadow Mountain Sensory Impact Study - Noise

Figure No.: **A.5**
 Title: **Nighttime Noise Contour 4.5 m (15ft.) AG**







470000

471000



Legend

-  Site Limit
-  Noise Receptor
-  Point Source
-  Daytime Noise Contour Lmax (dBA)
-  Line Source

470000

471000

4375000

4375000



- Notes**
1. Coordinate System: NAD 1983 UTM Zone 13N
 2. Base features produced under creative commons license with the Colorado Department of Transportation © 2022.
 3. Orthoimagery © 2023 Microsoft Corporation © 2023 Maxar © CNES (2023) Distribution Airbus DS

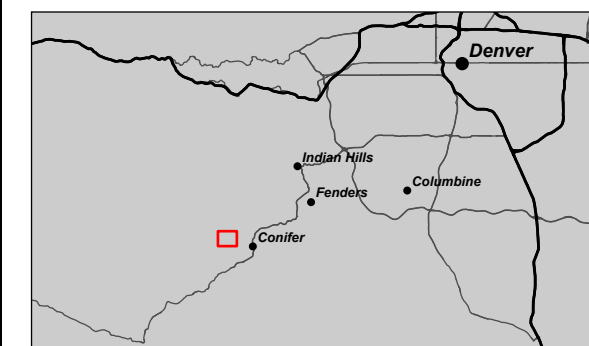

Project Location: Jefferson County, CO
 Prepared by MDA on 2023-11-30
 Technical Review by BCC on 2023-11-30

Client/Project: SE Group
 Shadow Mountain Sensory Impact Study - Noise

Figure No.: **A.6**
 Title: **Daytime Noise Contour L_{max} (dBA)**

4375000

4375000



\\va004-dp1es04\work_group\01609\active_Other_POs_Active\009_GIS\181711248\03_data\figs_cad\figs\noise\report_figures\noise_181711248_noise_is_spr181711248_fig06_Day_Lmax_Revise02-2023-11-30_By:malazarem

**ENGINEERING STUDY
for
SHADOW MOUNTAIN BIKE PARK
CONCEPT MASTER PLAN
WATER SYSTEM IMPROVEMENTS**

Prepared For:

**Colorado State Land Board
Shadow Mountain Bike Park
SE Group
Frisco, Colorado
PO Box 2729
323 West Main Street, Suite 202
Frisco, CO 80443-2729**

Prepared By:

Stantec

5725 Mark Dabling Blvd. Suite 190
Colorado Springs CO 80919

**November 2022
Revised October 2023
Project No. 181711248**

***** CONTENTS *****

Section 1	EXECUTIVE SUMMARY	1
Section 2	INTRODUCTION	2
2.1	Purpose	2
2.2	Scope	2
Section 3	EXISTING CONDITIONS	3
3.1	Description of Service Area	3
3.2	Land Use	3
3.3	Topography and Floodplains	3
3.4	Geology	3
3.5	Groundwater	3
3.6	Climate	6
3.7	Natural Hazards Analysis	6
3.8	Organizational Context	6
3.9	Water Facilities	6
3.10	Relationship to Neighboring Water and Wastewater Facility	7
3.11	Water Demand	7
Section 4	DEVELOPED CONDITIONS	9
4.1	Land Use	9
4.2	Population and Employment	10
4.3	Water Demand	10
4.4	Water Supply	12
4.5	Water Quality	12
4.6	Fire Flow Requirements	12
Section 5	WATER SYSTEM IMPROVEMENTS	13
5.1	General	13
5.2	Groundwater Wells	13
5.3	Treatment	13
5.4	Storage	13
5.5	Distribution	13
5.6	Estimated Costs	14
5.7	Rates and Charges	14

******* APPENDICES *******

Appendix A 100-Year Flood Plain Certification
Appendix B Water System Improvement

******* LIST OF FIGURES *******

Figure 1 Vicinity Map

Section 1
EXECUTIVE SUMMARY

This report presents the results of the engineering study for water system improvements serving Shadow Mountain Bike Park proposed on State Land Board Shadow Mountain parcels in Jefferson County, Colorado. Shadow Mountain Bike Park is proposed on undeveloped property with a designated address of 29611 Shadow Mountain Drive, Conifer, Colorado 80433.

The proposed parcel currently has no water facilities on site. Shadow Mountain Bike Park proposes construction of a minimum of one water well to provide potable water to the site facilities through a private water system.

Shadow Mountain Bike Park facilities will consist of a Base Lodge operating as a Class III Recreation facility to welcome guests and provide basic needs such as welcoming center including drinking water and restrooms.

The average annual water demand for Shadow Mountain Bike Park is estimated to be 1.57 acre-feet of water per year. Average day usage is estimated to be approximately 1400 gpd or 0.97 gpm. This water will be provided by water wells as permitted by the Colorado State Engineers Office.

To meet Drinking Water Standards water will be filtered (if required) and disinfected prior to storage and will meet Colorado Department of Health and Environment Drinking Water Standards.

Fire Protection is provided by the Elk Creek Fire Protection District. Discussions with District Representatives indicate that they will require on-site fire protection that can provide 1500 gpm for 2 hours. To meet this requirement onsite Fire Storage will need to be 180,000 gallons exclusive of storage required for domestic use. This storage will be provided in a separate Fire Storage only ground storage tank; fire flow will be conveyed to the site through a fire flow distribution system to on-site fire hydrants.

Section 2 INTRODUCTION

2.1 Purpose

The purpose of this report is to present water system improvements recommended to serve Shadow Mountain Bike Park; a proposed recreational development project located in Jefferson County. It is also intended to serve as a guideline for the ensuing design of recommended improvements.

2.2 Scope

The scope of this report includes:

1. The definition of the service areas as well as identification of significant physical and environmental characteristics and constraints.
2. An analysis of available data to determine existing and to project future water supplies, demands and quality.
3. A description of legal, institutional and managerial arrangements that ensure adequate control of the proposed improvements; and,
4. A preliminary recommendation for a selected supply, treatment, pumping and transmission alternatives.

Section 3 EXISTING CONDITIONS

3.1 Description of the Service Area

Shadow Mountain Bike Park consists of approximately 235 acres of Base Lodge (10 acres +/-) and open space uses and is located northwest of Conifer, Colorado, within Township 6 South, Range 71 West, Section 16.

3.2 Land Use

Shadow Mountain Bike Park is in Jefferson County northwest of Conifer, Colorado and about 35 miles southwest of the Denver Metroplex. Surrounding areas are primarily large tract residential properties and large undeveloped tracts.

3.3 Topography and Floodplains

The topography of the service area is typical of a Colorado Front Range Mountain parcel with elevations ranging from 8400 ft. to 9250 ft. above sea level. Existing slopes range from 5% at base camp to 25% or greater in some areas. Vegetation is typical Colorado mountain woodlands with a mix of Ponderosa Pine, Spruce, Fir and ground cover plants and grasses. The area drains generally northeast to North Turkey Creek.

There is no Federal Emergency Management Agency (FEMA 08059CO365F) established floodplain within the boundaries of Shadow Mountain Bike Park. See Appendix A.

3.4 Geology

The site is comprised of several different soil types. From the NRCS Soil Survey of Jefferson County, the site falls into the following soil types:

1. "67" Kittredge-Earcree, 9 to 20 percent slopes; Type A Soil
2. "76" Legault-Hiwan stony loamy sands, 15 to 30 percent slopes; Type D Soil
3. "77" Legault-Hiwan-Rock outcrop complex, 30 to 50 percent slopes; Type D Soil
4. "138" Rock outcrop, igneous and metamorphic; Type D Soil
5. "141" Rogert, very stony-Herbman-Rock outcrop complex, 30 to 70 percent slopes; Type D Soil

Note: "#" indicates Soil Conservation Survey soil classification number.

3.5 Groundwater

The proposed water supply for the Shadow Mountain Bike Park is an onsite water well. The applicant has been in discussion with the State Engineers Office concerning a well permit for the site including the type of permit and the uses permitted to ensure proper permitting. There are numerous wells in the area and discussions with the State indicate issuance of a permit could be made based on water rights associated with the property without injury to adjacent water rights.

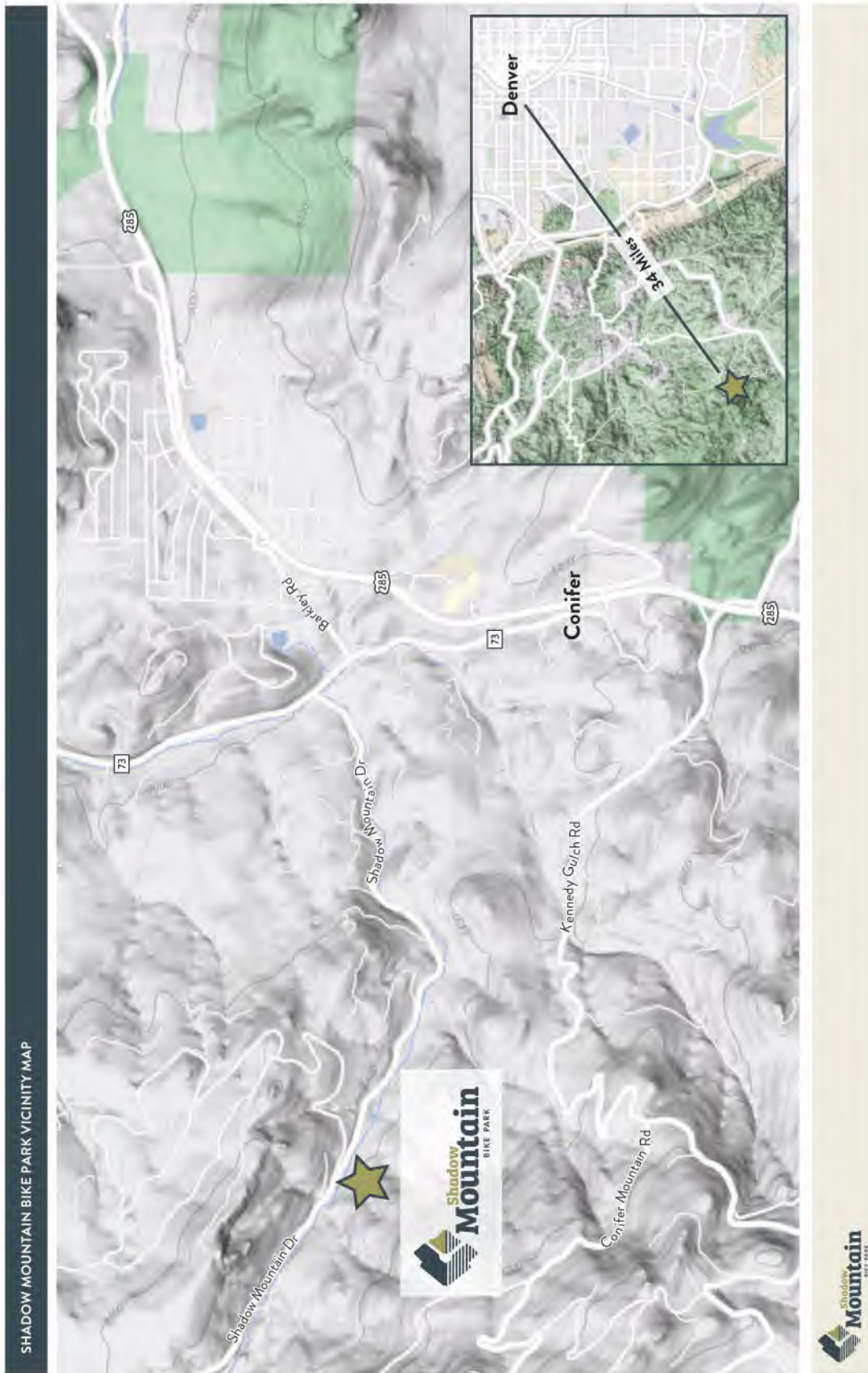

Figure 1: Vicinity Map

3.6 Climate

The climate of the study area is characterized by mild summers and moderately severe winters, moderate precipitation, high evaporation, and moderately high wind velocities.

The average annual monthly temperature is 43.5 F with an average monthly low of 10.3 F in the winter and an average monthly high of 76.1 F in the summer.

Precipitation averages 17.3 inches annually, with 50% of this falling as snow. August is the wettest month and January is the driest. The average annual Class A pan evaporation is 45 inches.

3.7 Natural Hazards Analysis

Natural hazards analysis indicates that no unusual surface or subsurface hazards are located in the service area. However, because the soils are cohesionless, sloughing of steep banks during drilling and/or excavation could occur. By siting improvements in a manner that provides an opportunity to lay the banks of excavations back at a 1:1 slope during construction, the problems associated with sloughing soils can be minimized.

3.8 Organizational Context

Shadow Mountain Bike Park is situated within the North Turkey Creek basin of Jefferson County. The closest public water supplier would be Mountain Water and Sanitation District in Conifer, Colorado. The distance and topography to Conifer in general is cost prohibitive in terms of a water supplier for the bike park.

The amount of water required for the facility and the distance to other providers makes an onsite private water system the best for meeting on-site demands. The Mountain Shadow Bike Park will be the entity responsible to finance, construct and ensure the continuing operation and maintenance of improvements.

3.9 Water Facilities

The proposed water system will consist of a minimum of one water well onsite and water treatment and disinfection based on source water conditions and Colorado Department of Health and Environment requirements. In addition, there will be a 6-inch water transmission line from the water well to the storage tank. Water will be stored to provide peak hour demand and fire sprinkler water for the onsite Base Lodge.

3.10 Relationship to Neighboring Water and Wastewater Facilities

Mountain Water and Sanitation District near Conifer, Colorado is the closest potential provider of water and wastewater facilities. The distance and topography between the site and the town make any connection cost prohibitive.

3.11 Water Demand

The Shadow Mountain Bike Park recreational development will be serviced by a private water system constructed by the developer of the bike park. The projected water demand for the facility is calculated in Section 4.3 Water Demand based on uses recorded at other Bike Park facilities.

Section 4
DEVELOPED CONDITIONS

4.1 Land Use

Mountain Shadow Bike Park consists of approximately 235 acres of State Land Board undeveloped property. Most of the site will be left undeveloped except for the addition of Bike Trails, a bike lift and development of approximately 10 acres for a base lodge including one building for welcoming, ticketing, water facilities and restrooms.

Assumptions: Employees water usage is estimated to be 10 gallons per day (gpd)
Guest Water Usage is estimated to be 4 gpd
Irrigation will be minimal or not required with xeriscape or extensions of the natural surroundings.

4.2 Population and Employment

The applicant estimates that there will be 20 onsite employees in a given day. The average day guest population is estimated to be 300.

4.3 Water Demand

Water demand is estimated to be as follows:

Employees	20 x 10 gpd =	200 gpd
Guests	300 x 4 gpd =	<u>1200 gpd</u>
Total =		1400 gpd =511,000 gallons/year =1.57 ac-ft/year

Unit water demands are based on the applicants' experience at other similar facilities.

Water demand is calculated in acre-feet per year (AFY) to determine water supply needs. This value is then factored to determine the average daily demand (ADD) in gallons per minute (gpm), which is used to project maximum day and peak hour demands as well as to estimate revenues and operating costs. Maximum day demand (MDD) and peak hour demand (PHD) have been determined by applying accepted peaking factors of 2.5 and 4.0 to the ADD, respectively. The MDD is used to determine storage needs and the PHD is used for modeling system delivery pressures and to size distribution piping.

Demand

Ac-Ft/Year =	1.57
Gallons/day=	1400
ADD gpm=	0.97
MDD gpm=	2.43
PHD gpm=	3.8

Estimated Building Sprinkler demand is 20 gpm for 2 hours or 2400 gallons.

4.4 Water Supply

The proposed water supply for the Shadow Mountain Bike Park is an onsite water well. The applicant has been in discussion with the State Engineers Office concerning a well permit for the site including the type of permit and the uses permitted to ensure proper permitting. There are numerous wells in the area and discussions with the State indicate issuance of a permit could be made based on water rights associated with the property without injury to adjacent water rights. Most of the wells in the area range between 350 ft to over 600 ft. in depth. The nearby wells all indicate access to an “unnamed” aquifer and are all located in a “non-designated” basin.

Based on information from adjacent properties we would anticipate construction and completion of a water well between 500 and 600 ft. in depth in an unnamed aquifer.

The water well permit should be for a well capable of producing at a minimum the anticipated Peak Hour Demand and overall, yearly withdraw limits should exceed 2 ac-ft (651,657 gallon) annually.

4.5 Water Quality

The water quality and any mitigation required will be determined after construction of the well based on the permit obtained from the State Engineers Office. Mitigation anticipated may include filtering and disinfection. Anticipated treatments expected would be easily obtained with standard readily available locally provided treatment and disinfection equipment.

4.5 Fire Flow

Fire Protection is provided by the Elk Creek Fire Protection District. Discussions with District Representatives indicate that they will require on-site fire protection that can provide 1500 gpm for 2 hours. To meet this requirement onsite Fire Storage will need to be 180,000 gallons exclusive of storage required for domestic use.

In most domestic water systems, the Fire Storage component is 20 to 30% of the overall storage requirement. In this case the Fire Storage component is 92%. Storing water for long periods of time can lead to water quality issues primarily related to taste. Because of this concern, the domestic storage and the fire storage will likely need to be separated.

Fire Storage can be addressed in one of two ways and evaluation of the best alternative will need to continue through the Design Phase to determine the most economical and efficient system.

Ground Storage or Cistern with a Fire Pump

This system would require a 180,000-gallon ground storage tank approximately 30 feet in diameter and approximately 30 feet tall. Or alternatively a below grade 180,000 gallon cistern approximately 50 feet x 50 feet x 10 feet deep. Along with the storage there would be a requirement to install a 1500 gpm fire pump to deliver water at 20 psi. This type fire pump would require a 25 HP motor. Included with the design would be a backup generator and fuel storage to provide electricity to the pump if the power failed during a fire.

Ground storage/elevated Fire Storage.

This system would require a 180,000-gallon storage tank approximately 30 feet in diameter and 30 feet tall located at an elevation approximately 50 feet higher than the facility. No fire pump or backup generator

would be required, but approximately 2100 feet of transmission pipe would be required to convey water from the site to the tank.

In both cases some pipe would need to be located around the site to distribute to fire hydrant locations (2 maximum).

It would take a 10 gpm well approximately 12.5 days to fill the fire storage tank.

Some type of disinfection and/or aeration may be required in either system to prevent growth of bacteria that could interfere with the distribution of fire flow.

Evaluation of the two potential fire storage options will continue with final design. However, in order to avoid the expense of a large fire pump and backup generator and to use the advantage of gravity flow this report will assume the use of the second option; a ground storage elevated tank.

Section 5
WATER SYSTEM IMPROVEMENTS

5.1 General

The water system would be operated by the Shadow Mountain Bike Park and would be classified as a private water system and would be operated to meet the applicable requirements of the Colorado Department of Health and Environment (CDHE). The system may be operated by a third party contracted by Shadow Mountain Bike Park and licensed by the State of Colorado.

Filtration and disinfection facilities provide treatment of the raw water sources to ensure good water quality. In addition, storage facilities and distribution piping will be provided to ensure that residual pressure requirements are achieved both during peak hour demands and during maximum day demands. The system will also be designed to deliver the required fire sprinkler water to the onsite building.

5.2 Groundwater Wells

The proposed water supply for the Shadow Mountain Bike Park is an onsite water well. As mentioned previously, the applicant has been in contact with the State Engineers Office concerning the parameters of a permit.

The water well permit should be for a well capable of producing at a minimum the anticipated Peak Hour Demand and overall, yearly withdraw limit should exceed 2 ac-ft annually.

The well will be equipped with a submersible well pump capable of delivering in excess of the Peak Hour Demand of 3.8 gpm. The well pump would be designed to deliver water to the domestic storage tank and fire tank.

5.3 Water Treatment

Treating and filtering of the water sources will meet CDHE Drinking Water Standards.

In addition, CDHE standards require that the water supply be disinfected and that the supply receives minimum chlorine contact time of 30 minutes before first use.

5.4 Storage

Storage reservoirs will be ground mounted and elevated steel tanks designed in accordance with CDHE and AWWA Standards.

Potable Water Storage is sized to provide a minimum of 30% of maximum day demand. Required storage is calculated as follows:

Maximum Day Demand is 3.8 gpm. $3.8 \times 60 \times 24 = 5,472$ gallons

Estimated Storage Requirement = 5,472 gallons say 7,500 gallons

Tank size could be doubled to allow for special events. Normal operation would be between 5000 and 7500 gallons. Actual storage requirements and operational characteristics will be addressed as final design proceeds.

Fire Demand Storage will be 180,000 gallons as stated in section **4.5 Fire Flow**. Water stored for fire flow will not be considered potable due to disinfection required to maintain functional fire flow storage for long periods of time without use.

5.5 Distribution

The water distribution system provides water at a maximum static pressure of 45 psi during periods of low use and at a minimum residual pressure of 40 psi during peak hour demand. The storage tank will be located at an elevation sufficient to meet these pressure requirements along with associated distribution and conveyance piping. Anticipated transmission and distribution piping is 6-inch.

Fire flow will be conveyed in its own distribution system to 2 fire hydrants located with the fire district input around the site near the building during final design. Each fire hydrant will be capable of conveying 1500 gpm at a minimum pressure of 20 psi. The anticipated fire system piping will be 6-inch minimum diameter.

5.6 Estimated Costs

Estimated Costs

Item	Units	Quantity	Unit Price	Extension
Shadow Mountain Bike Park				
Water Well	LS	1	\$50,000	\$50,000
Well Pump and Controls	LS	1	\$15,000	\$15,000
Potable Water Transmission	LF	5,800	\$35	\$203,000
Potable Storage	Gallons	15,000	\$3	\$45,000
Fire Storage Transmission	LF	2,500	\$35	\$87,500
Fire Storage	Gallons	180,000	\$2	\$360,000
Treatment	LS	1	\$40,000	\$40,000
Total Estimated Cost				\$800,500

The above system improvements are all constructed as part of Shadow Mountain Bike Park. These costs do not include other costs or gains that may be incurred in the acquisition of land, financing, investment, local distribution, the salvage value of equipment or other necessary infrastructure, among others, unless specifically noted. The above costs are estimated, actual costs may differ depending upon numerous factors including supply chain, and cost increases at time of bidding.

5.7 Rates and Charges

The waters system will be operated within the overall operation of the Shadow Mountain Bike Park through user fees charged to guests for the recreational facility.

Appendix A

100 Year Flood Plain Certification

Appendix B

Water System Improvements



2000 S COLORADO BLVD
SUITE 300
DENVER, CO 80222

WATER SYSTEM SITE DRAWING (A)

SHADOW MOUNTAIN BIKE PARK

SCALE: 1"=60'

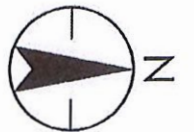

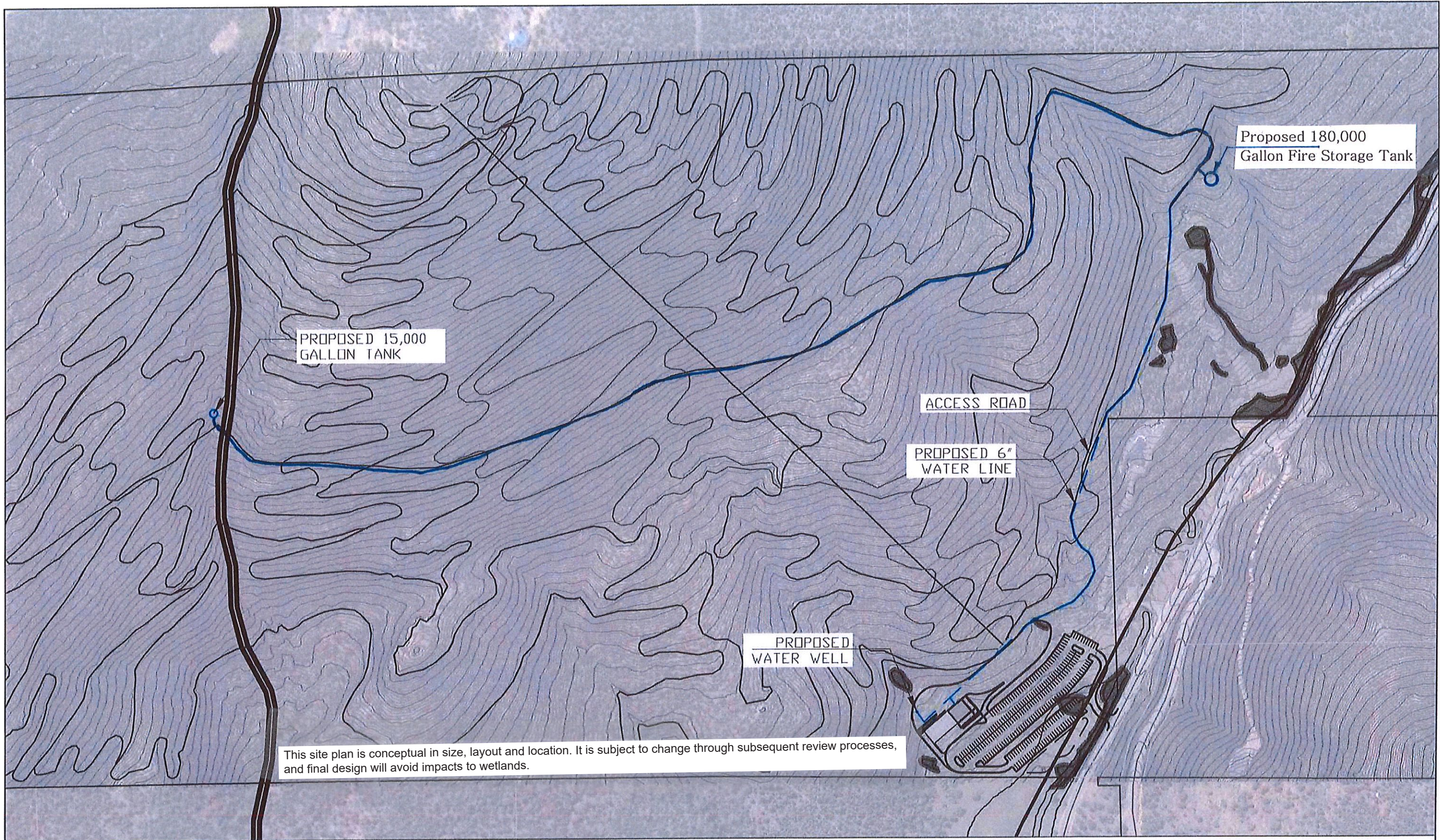

This site plan is conceptual in size, layout and location. It is subject to change through subsequent review processes, and final design will avoid impacts to wetlands.



2000 S COLORADO BLVD
SUITE 300
DENVER, CO 80222

WATER SYSTEM SITE DRAWING (B)

SHADOW MOUNTAIN BIKE PARK

SCALE: 1"=300'





April 12, 2024

Jefferson County – Planning and Zoning
100 Jefferson County Parkway, Suite 3550
Golden, CO 80419
Attn: Dylan Monke, Planner

Re: Shadow Mountain Bike Park - Case No. Case No. 23-102980 RZ

Dear Mr. Monke,

We are in receipt of the Second Referral Response Letter from Jefferson County Historical Commission (“JCHC”), dated January 22, 2024, as part of the second referral of the application for a special use for the Shadow Mountain Bike Park project (the “**Application**”). We understand that we have satisfied a number of the JCHC’s recommendations from their First Referral Response Letter dated May 10, 2023. After further consideration and review of additional information provided by a local resident, the JCHC responded to our Second Referral by recommending the following:

Recommendation 1. A Historical, Archaeological and Paleontological Report/(Plan) shall be prepared in accordance with Land Development Regulation, Section 31 and shall address the alternatives for protection of any historical, archaeological and/or paleontological sites. Once the Historical, Archaeological and Paleontological Plan is completed and approved, if historical, archaeological and paleontological resources are present or discovered during site preparation, the applicant shall notify the Jefferson County Planning and Zoning Division to determine the disposition and necessary protection, excavation, or recovery of the resource(s).

Recommendation 2. The mountain and historic landscape are basically intact throughout the project area. JCHC will work with the applicant to consider this landscape during project design and developing mitigation measures.

Recommendation 3. Although the applicant is not required to conduct an on-the-ground survey, JCHC believes it is the most reliable approach for identifying cultural resources and reducing potential impacts to them during planning and not during development, which can result in project delays and unnecessary damage to cultural resources.

In response to these recommendations, we scheduled a meeting with the JCHC to better understand their expectations and establish next steps. In the meeting, we discussed our commitment to an on-the-ground survey in certain parts of the project area and suggested delaying the preparation of an Historical, Archaeological, and Paleontological Report/Plan until the design/development phase, since a report would be prepared to describe the project area and survey results at that point anyway. In the meeting, JCHC was willing to consider these next steps and accept a response letter (this letter) instead of a Report/Plan in this referral. Lastly, we discussed next steps, and from that conversation, we commit to the following measures:

- We will prepare a Historical, Archaeological, and Paleontological Report/Plan in accordance with Land Development Regulation, Section 31. The information required according to LDR Section 31 will be included in the report that follows cultural surveys as required per Section 106 compliance.
- We are committed to conducting cultural surveys in areas with higher levels of ground disturbance, which includes: the driveway, parking lot/base area, and area around the top of the chairlift.
- We would like to invite a member of JCHC to assist in the flagging of trail alignments during the design and development phase to determine the presence (or likelihood therein) of cultural resources, if necessary.
- If historical, archaeological and paleontological resources are discovered during site preparation or construction, all construction in the immediate vicinity shall cease and the applicant shall notify the Jefferson County Planning and Zoning Division and the proper authorities to determine the disposition and necessary protection, excavation, or recovery of the resource(s).

We understand the importance of preserving historical, archaeological, and paleontological resources and is committed to prioritizing the protection of resources, if present within the project area. If the Application is approved by the County, we would work with the Jefferson County Historical Commission, the Conifer Historical Society, and other cooperating agencies to fulfill the requirements for this resource, establish mitigation measures where necessary, and continue the project planning accordingly.

Sincerely,



Phil Bouchard
Shadow Mountain Bike Park



Jason Evans
Shadow Mountain Bike Park



April 17, 2023

Jefferson County – Planning and Zoning
100 Jefferson County Parkway, Suite 3550
Golden, CO 80419
Attn: Dylan Monke, Planner

Re: Application for Special Use - 23-102980 RZ, Additional Water Supply Information

Dear Mr. Monke:

We are in receipt of the Second Referral Response Letter from the Jefferson County Engineering Geologist seeking additional information in regard to the Water Supply Information Summary, included as part of the Applicant's Special Use Application, Case No. 23-102980 RZ (the "**Application**"). This letter has been prepared to fulfill the Water Supply Information Summary requirement of our application and includes an updated well water permit application and engineer's report. The proposed bike park (the "**Project**") will require water use for daily operations, specifically in the proposed Day Lodge and in the Maintenance Building.

The following documents are provided in response to the comments received and are attached to this letter:

- Updated GW-45 General Purpose Water Well Permit Application, included as Attachment A, with updated legal description and withdrawal amount
- Updated Engineering Study for Water System Improvements, included as Attachment B, which incorporates and addresses the comments listed below.

Additionally, the following comments were received. Our responses to comments are included below. Additionally,

Comment 1. The site is not within a zoned or unzoned geologic hazard area and reports are not required with the rezoning process.

Response: Comment noted.

Comment 2. The property is located within the Mountain Ground Water Overlay District. Based the uses (bike park, lodge, maintenance building) on 306 acres, it appears the water requirement will not exceed the 0.28 acre feet per acre per year threshold as described in Section 21 of the LDR. If the water requirement exceeds 0.28 acre feet per acre per year, an Aquifer Test in accordance with Section 21 of the LDR is required with the rezoning application. If the water requirement exceeds 0.10 acre feet per acre per year, an Aquifer Test in accordance with Section 21 of the LDR is required with the SDP application.

Response: Comment noted. The Project is anticipated to remain well below the 0.28 acre feet per acre per year threshold. From initial calculations in the WAA spreadsheet provided

by the County, it is estimated that the Project would remain below 0.05 acre feet per acre per year (refer to Appendix C of Attachment B).

Comment 3. The applicant had previously submitted a plan that describes the process to obtain legal rights to the water supply, however, the number of guests has been updated (1200 max) and the plan should be updated with the revised values. Adequate legal water rights will be required with the SDP process.

Response: We have updated both engineer reports for the Water Supply Information Summary and the Onsite Wastewater Treatment System items based on this maximum guest use and the sources provided below. These are both included in this second referral resubmittal package and the water report is attached to this letter.

Comment 4. The Water Availability Analysis (WAA) has been completed based on water demand requirements listed in the Jefferson County OWTS regulations. The use is unique and a bike park is not listed, therefore, County staff referenced a “camps, day, no meals served” value in the WAA. The value utilized is 15 gallons per day (gpd) per guest (1200 guests based on revised ODP). The value utilized in Stantec’s October 23, 2023 Engineering Study was 4 gpd, however, no source data was provided. I discussed this with the applicant’s representative. Based on the values and ODP, the estimated consumptive use is ~2.6 af/yr.

Response: We followed up with Patrick O’Connell on this comment and had several conversations surrounding water uses, the Water Availability Analysis, and data sources. We have reached out to other similar facilities and have two data sources that support approximately 4 gallons per day (gpd) per guest. The first source is Staunton State Park; they provided visitation and water use data for their 2021 through 2023 winter and summer seasons for their visitor center, which has four toilets, four sinks, one drinking fountain, and no restaurant use. They have this one facility at their one entry portal and offer recreation opportunities such as hiking, mountain biking, and picnicking, all of which resemble what is proposed at SMBP. In the data shared by Staunton State Park, water use per guest ranged from 1.0 – 4.4 gpd in this time period; however, this was at the same time that the park had a leak in their water pipe as well. After the leak was fixed, visitation and water use data indicated an average use per guest of 0.3 gpd. Because 4.4 gpd is the maximum in this dataset, even with the leak, we believe this fully supports a guest use of 4 gpd as a high estimate for a similar use in a nearby area.

Additionally, Mr. O’Connell obtained a week’s data of water use and visitation at the Valley restaurant at Loveland Ski Area in Colorado. This ski area is a similar distance from a metropolitan area (approx. one hour from Denver) and offers a developed recreation opportunity for this population. Additionally, the Valley facility offers guest services such as restrooms and a ski school children’s center as well as a bar, restaurant, and cafeteria (for a total of two kitchens in the facility). Water use from this data was estimated at 7-8 gpd per guest including restaurant use. The EPA estimates that approximately 31-45% of water use in restaurants, office buildings, and educational facilities is attributed to domestic/restrooms (which is the only use for SMBP guests), which supports the estimate of about 4 gpd per guest for SMBP’s type of use.

With these data sources, we feel confident in our estimate of approximately 4 gallons per day per guest and have provided an updated WAA to Mr. O'Connell with this estimate. Our estimate assumes guest use of 275 days per year (given the seasonal closure described in our Special Use Plan) and employee use of 365 days per year. Consumptive use would be approximately 0.76 af/yr with these assumptions.

Comment 5. The Engineering Study should be updated with data/references for the 4 gpd value. The applicant should review the WAA (xls format) and provide data/references for alternative values as appropriate.

Response: See response above.

1. Grading within the Jefferson County Floodplain Overlay District (flood prone area) will require a separate Floodplain Development Permit.

Response: Comment noted.

In addition to the comments above, we have spoken with our case manager and Mr. O'Connell about our approach to obtaining water rights and have agreed to outline it here. We intend to construct a well for water use during normal operations. Normal operations include bike park operations in April through December outside of Special Events, as well as occasional employee use for maintenance from January through April. Well water will be used for toilets, sinks, and water fountains. We will pursue a nonexempt commercial well permit and water augmentation plan for normal operations and understands that this would need to be obtained prior to Site Development Plan approval. The water augmentation plan will supply the facility with approximately 4.72 acre-feet per year (afy) of water, as anticipated based on the assumptions described herein and as described in the attached engineer's report for water supply. We anticipate that pursuing a nonexempt well permit and water augmentation plan for up to 4.72 afy will be a long process and therefore plan to pursue an exempt commercial well permit, limited by a maximum annual withdrawal of 108,600 gallons per year (approximately 0.33 afy), for uses during construction and the start of operations. This would be a temporary use and water use would be highly monitored so as to not exceed the maximum annual withdrawal under the duration of this permit. This and other supplemental alternatives such as hauling water have also been discussed with the Colorado Division of Water Resources (DWR) and could contribute towards guest water use; as such, the DWR understands our intention for next steps.

We are committed to the assumptions included herein and understand the sensitivity around additional water use for this type of development. We also would like to reiterate that other uses, such as the recommended residential use for the Property, would allow water use of up to 298 gpd for one single family home according to the Conifer/285-Corridor Area Plan, and up to 25 homes on the Property. This would amount to approximately 7,500 gpd for the property (approx. 1 afy of consumptive use), as opposed to a maximum use of 5,400 gpd (approx. 0.75 afy of consumptive use) as estimated for this Project. That being said, we are also committed to limiting our water use where possible by installing water efficient toilets and sinks, monitoring visitation, and addressing leaks or other errors in the system as soon as they're discovered. We hope that this response will help your understanding of this project and address your concerns.

Sincerely,

A handwritten signature in black ink, appearing to read 'Phil Bouchard', written in a cursive style.

Phil Bouchard
Shadow Mountain Bike Park

A handwritten signature in black ink, appearing to read 'Jason Evans', written in a cursive style.

Jason Evans
Shadow Mountain Bike Park

Attachment A



April 17, 2023

Jefferson County – Planning and Zoning
100 Jefferson County Parkway, Suite 3550
Golden, CO 80419
Attn: Dylan Monke, Planner

Re: Application for Special Use - 23-102980 RZ, Additional Water Supply Information

Dear Mr. Monke:

We are in receipt of the Second Referral Response Letter from the Jefferson County Engineering Geologist seeking additional information in regard to the Water Supply Information Summary, included as part of the Applicant's Special Use Application, Case No. 23-102980 RZ (the "**Application**"). This letter has been prepared to fulfill the Water Supply Information Summary requirement of our application and includes an updated well water permit application and engineer's report. The proposed bike park (the "**Project**") will require water use for daily operations, specifically in the proposed Day Lodge and in the Maintenance Building.

The following documents are provided in response to the comments received and are attached to this letter:

- Updated GW-45 General Purpose Water Well Permit Application, included as Attachment A, with updated legal description and withdrawal amount
- Updated Engineering Study for Water System Improvements, included as Attachment B, which incorporates and addresses the comments listed below.

Additionally, the following comments were received. Our responses to comments are included below. Additionally,

Comment 1. The site is not within a zoned or unzoned geologic hazard area and reports are not required with the rezoning process.

Response: Comment noted.

Comment 2. The property is located within the Mountain Ground Water Overlay District. Based the uses (bike park, lodge, maintenance building) on 306 acres, it appears the water requirement will not exceed the 0.28 acre feet per acre per year threshold as described in Section 21 of the LDR. If the water requirement exceeds 0.28 acre feet per acre per year, an Aquifer Test in accordance with Section 21 of the LDR is required with the rezoning application. If the water requirement exceeds 0.10 acre feet per acre per year, an Aquifer Test in accordance with Section 21 of the LDR is required with the SDP application.

Response: Comment noted. The Project is anticipated to remain well below the 0.28 acre feet per acre per year threshold. From initial calculations in the WAA spreadsheet provided

by the County, it is estimated that the Project would remain below 0.05 acre feet per acre per year (refer to Appendix C of Attachment B).

Comment 3. The applicant had previously submitted a plan that describes the process to obtain legal rights to the water supply, however, the number of guests has been updated (1200 max) and the plan should be updated with the revised values. Adequate legal water rights will be required with the SDP process.

Response: We have updated both engineer reports for the Water Supply Information Summary and the Onsite Wastewater Treatment System items based on this maximum guest use and the sources provided below. These are both included in this second referral resubmittal package and the water report is attached to this letter.

Comment 4. The Water Availability Analysis (WAA) has been completed based on water demand requirements listed in the Jefferson County OWTS regulations. The use is unique and a bike park is not listed, therefore, County staff referenced a “camps, day, no meals served” value in the WAA. The value utilized is 15 gallons per day (gpd) per guest (1200 guests based on revised ODP). The value utilized in Stantec’s October 23, 2023 Engineering Study was 4 gpd, however, no source data was provided. I discussed this with the applicant’s representative. Based on the values and ODP, the estimated consumptive use is ~2.6 af/yr.

Response: We followed up with Patrick O’Connell on this comment and had several conversations surrounding water uses, the Water Availability Analysis, and data sources. We have reached out to other similar facilities and have two data sources that support approximately 4 gallons per day (gpd) per guest. The first source is Staunton State Park; they provided visitation and water use data for their 2021 through 2023 winter and summer seasons for their visitor center, which has four toilets, four sinks, one drinking fountain, and no restaurant use. They have this one facility at their one entry portal and offer recreation opportunities such as hiking, mountain biking, and picnicking, all of which resemble what is proposed at SMBP. In the data shared by Staunton State Park, water use per guest ranged from 1.0 – 4.4 gpd in this time period; however, this was at the same time that the park had a leak in their water pipe as well. After the leak was fixed, visitation and water use data indicated an average use per guest of 0.3 gpd. Because 4.4 gpd is the maximum in this dataset, even with the leak, we believe this fully supports a guest use of 4 gpd as a high estimate for a similar use in a nearby area.

Additionally, Mr. O’Connell obtained a week’s data of water use and visitation at the Valley restaurant at Loveland Ski Area in Colorado. This ski area is a similar distance from a metropolitan area (approx. one hour from Denver) and offers a developed recreation opportunity for this population. Additionally, the Valley facility offers guest services such as restrooms and a ski school children’s center as well as a bar, restaurant, and cafeteria (for a total of two kitchens in the facility). Water use from this data was estimated at 7-8 gpd per guest including restaurant use. The EPA estimates that approximately 31-45% of water use in restaurants, office buildings, and educational facilities is attributed to domestic/restrooms (which is the only use for SMBP guests), which supports the estimate of about 4 gpd per guest for SMBP’s type of use.

With these data sources, we feel confident in our estimate of approximately 4 gallons per day per guest and have provided an updated WAA to Mr. O'Connell with this estimate. Our estimate assumes guest use of 275 days per year (given the seasonal closure described in our Special Use Plan) and employee use of 365 days per year. Consumptive use would be approximately 0.76 af/yr with these assumptions.

Comment 5. The Engineering Study should be updated with data/references for the 4 gpd value. The applicant should review the WAA (xls format) and provide data/references for alternative values as appropriate.

Response: See response above.

1. Grading within the Jefferson County Floodplain Overlay District (flood prone area) will require a separate Floodplain Development Permit.

Response: Comment noted.

In addition to the comments above, we have spoken with our case manager and Mr. O'Connell about our approach to obtaining water rights and have agreed to outline it here. We intend to construct a well for water use during normal operations. Normal operations include bike park operations in April through December outside of Special Events, as well as occasional employee use for maintenance from January through April. Well water will be used for toilets, sinks, and water fountains. We will pursue a nonexempt commercial well permit and water augmentation plan for normal operations and understands that this would need to be obtained prior to Site Development Plan approval. The water augmentation plan will supply the facility with approximately 4.72 acre-feet per year (afy) of water, as anticipated based on the assumptions described herein and as described in the attached engineer's report for water supply. We anticipate that pursuing a nonexempt well permit and water augmentation plan for up to 4.72 afy will be a long process and therefore plan to pursue an exempt commercial well permit, limited by a maximum annual withdrawal of 108,600 gallons per year (approximately 0.33 afy), for uses during construction and the start of operations. This would be a temporary use and water use would be highly monitored so as to not exceed the maximum annual withdrawal under the duration of this permit. This and other supplemental alternatives such as hauling water have also been discussed with the Colorado Division of Water Resources (DWR) and could contribute towards guest water use; as such, the DWR understands our intention for next steps.

We are committed to the assumptions included herein and understand the sensitivity around additional water use for this type of development. We also would like to reiterate that other uses, such as the recommended residential use for the Property, would allow water use of up to 298 gpd for one single family home according to the Conifer/285-Corridor Area Plan, and up to 25 homes on the Property. This would amount to approximately 7,500 gpd for the property (approx. 1 afy of consumptive use), as opposed to a maximum use of 5,400 gpd (approx. 0.75 afy of consumptive use) as estimated for this Project. That being said, we are also committed to limiting our water use where possible by installing water efficient toilets and sinks, monitoring visitation, and addressing leaks or other errors in the system as soon as they're discovered. We hope that this response will help your understanding of this project and address your concerns.

Sincerely,

A handwritten signature in black ink, appearing to read 'Phil Bouchard', written in a cursive style.

Phil Bouchard
Shadow Mountain Bike Park

A handwritten signature in black ink, appearing to read 'Jason Evans', written in a cursive style.

Jason Evans
Shadow Mountain Bike Park

Attachment A

COLORADO DIVISION OF WATER RESOURCES
DEPARTMENT OF NATURAL RESOURCES
 1313 SHERMAN ST, RM 821, DENVER, CO 80203
 Main: (303) 866-3581 dwrpermitsonline@state.co.us

Office Use Only

Form GWS-45 (01/2020)

GENERAL PURPOSE

Water Well Permit Application

Review instructions on reverse side prior to completing form.
 The form must be computer generated, typed or in black or blue ink.

1. Applicant Information

Name of applicant
FSBR, LLC

Mailing address
32372 Lodgepole Drive

City State Zip code
Evergreen CO 80439

Telephone # (area code & number) E-mail (online filing required)
603-660-6604 phil@shadowmountainbikepark.com

2. Type Of Application (check applicable boxes)

Construct new well Use existing well
 Replace existing well Change or increase use
 Change source (aquifer) Reapplication (expired permit)
 COGCC Well Other: _____

3. Refer To (if applicable)

Well permit # _____ Water Court case # _____
 Designated Basin Determination # _____ Well name or # _____

4. Location Of Proposed Well

County
Jefferson

Section Township N or S Range E or W Principal Meridian
16 6 N S 71 E W 6

Distance of well from section lines (section lines are typically not property lines)
1930 Ft. from N S **2105** Ft. from E W

For replacement wells only – distance and direction from old well to new well
 _____ feet _____ direction

Well location address (Include City, State, Zip) Check if well address is same as in Item 1.
Shadow Mountain Drive, Conifer, CO, 80433

Optional: GPS well location information in UTM format You must check GPS unit for required settings as follows:

Format must be UTM
 Zone 12 or Zone 13
 Units must be Meters
Datum must be NAD83
 Unit must be set to true north
 Was GPS unit checked for above? YES NO
 Remember to set Datum to NAD83

5. Parcel On Which Well Will Be Located (PLEASE ATTACH A CURRENT DEED FOR THE SUBJECT PARCEL)

A. Legal Description (may be provided as an attachment):
See attachment

B. # of acres in parcel C. Owner
306 Colorado State Land Board

D. Will this be the only well on this parcel? YES NO (if no list other wells)

E. State Parcel ID# (optional):
61-163-00-001

6. Use Of Well (check applicable boxes)

Attach a detailed description of uses applied for.

Industrial Dewatering System
 Municipal Geothermal (production or reinjection)
 Irrigation Other (describe): _____
 Commercial

7. Well Data (proposed)

Maximum pumping rate	gpm	Annual amount to be withdrawn
7.5		4.72 acre-feet
Total depth	feet	Aquifer
600		unnamed

8. Land On Which Ground Water Will Be Used

Legal Description of Land (may be provided as an attachment):
See attachment

(If used for crop irrigation, attach a scaled map that shows irrigated area.)

A. # Acres B. Owner
306 Colorado State Land Board

C. List any other wells or water rights used on this land:

9. Proposed Well Driller License #(optional):

10. Sign or Entered Name Of Applicant(s) Or Authorized Agent

The making of false statements herein constitutes perjury in the second degree, which is punishable as a class 1 misdemeanor pursuant to C.R.S. 24-4-104 (13)(a). I have read the statements herein, know the contents thereof and state that they are true to my knowledge.

Sign or enter name(s) of person(s) submitting application _____ Date (mm/dd/yyyy) _____

If signing print name and title _____

Office Use Only

USGS map name	DWR map no.	Surface elev.
Receipt area only		
AQUAMAP		
WE		
WR		
CWCB		
TOPO		
MYLAR		
SB5	DIV _____	WD _____ BA _____ MD _____

GENERAL PURPOSE WELL PERMIT APPLICATION INSTRUCTIONS

Applications must be computer generated on-line, typewritten or printed in BLACK or BLUE INK. ALL ITEMS in the application must be completed. Incomplete applications may be returned to the applicant for more information. Applications are evaluated in chronological order. Please allow approximately six weeks for processing. This form may be reproduced by photocopying or computer generation. Reproductions must retain margins and print quality of the original form. If filing online see online filing instructions! You may also save, print, scan and email the completed form to: dwrpermitsonline@state.co.us For further information please visit dwr.colorado.gov

FEES: This application requires a nonrefundable \$100.00 filing fee. Please visit [DWR's Online Form Submittal](#) web page for acceptable payment information or contact DWR at (303) 866-3581.

USES: This form (GWS-45) is to be used to apply for commercial, industrial, municipal, irrigation, feed lot, geothermal (see Geothermal Rules for fee requirements), recovery wells, and other uses not otherwise noted in the following list:

RESIDENTIAL use wells – Use of form GWS-44 is required
LIVESTOCK watering on a farm, ranch, range or pasture (not feedlots) – Use form GWS-44
MONITORING/OBSERVATION wells – Use form GWS-46
GRAVEL PITS – Use form GWS-27
REGISTRATION of an existing well – Use form GWS-12 (must have been in use prior to May 8, 1972)
GEOEXCHANGE SYSTEM LOOP FIELDS – Use form GWS-72
REPLACEMENTS OF WELLS FOR THE ABOVE USES

ITEM INSTRUCTIONS: (numbers correspond with those on the front of this form)

1. The applicant is the entity for whom the permit is to be issued. Provide the applicant name and the mailing address where all correspondence will be sent.
2. Check all boxes that apply.
3. Complete all boxes that apply. If the permit is to be issued pursuant to a water court decree or a Designated Basin determination of water right, the case number or determination number must be indicated. If applying to replace or change the use of an existing well, the permit number of the existing well must be indicated.
4. The county, $\frac{1}{4}$ of the $\frac{1}{4}$ section designation, section #, township, range, principal meridian, and distances from section lines for the proposed well must be provided. (An option to providing distances from section lines and the $\frac{1}{4}$ of the $\frac{1}{4}$ section designation is to provide an accurate GPS location in UTM format. The required GPS unit settings must be as indicated on this form.) Colorado contains two (2) UTM zones. Zone 13 covers most of Colorado. The boundary between Zone 12 and Zone 13 is the 108th Meridian (longitude). West of the 108th Meridian is UTM Zone 12 and east of the 108th Meridian is UTM Zone 13. The 108th Meridian is approximately 57 miles east of the Colorado-Utah state line. On most GPS units, the UTM zone is given as part of the Easting measurement, e.g. 12T0123456. Check the appropriate box for the zone. Provide the property address of the well location if one exists. If it is the same as the mailing address, check the box next to the well location address.
5. **Please attach a current deed for the subject parcel.** Complete all boxes and provide a complete legal description of the parcel of land on which the well will be located. **If filing online please see online filing instructions for how to submit deed and or legal description attachments.**
6. Check all boxes that apply and attach a detailed description of the uses applied for.
7. Complete all boxes.
8. Complete all boxes and provide a legal description of the land areas on which ground water from the proposed well will be used. If agricultural irrigation is a proposed use, provide a map of the land area with proposed irrigated areas accurately drawn, including section numbers and section lines. A list of all other wells or water rights used on the described land must be provided.
9. The well must be constructed by a Colorado licensed well driller, an authorized individual in accordance with the Water Well Construction Rules, 2 CCR 402-2, or under the "private driller" provision as defined in CRS 37-91-102(12). A listing of licensed well drillers/pump installers is available [here](#).
10. The individual signing the application or entering their name and title must be the applicant or an officer of the corporation/company/agency identified as the applicant or their attorney. An authorized agent may also sign the application, if a letter signed by the applicant or their attorney is submitted with the application authorizing that agent to sign or enter their name on the applicant's behalf. If you filled the form out on-line you may save or print, sign, scan and email the form to the Division of Water Resources. Payment must be received via phone, fax or mail prior to processing the application.

IF YOU HAVE ANY QUESTIONS regarding any item on the application form, please call the Division of Water Resources Ground Water Information Desk (303-866-3587), or the nearest Division of Water Resources Field Office located in Greeley (970-352-8712), Pueblo (719-542-3368), Alamosa (719-589-6683), Montrose (970-249-6622), Glenwood Springs (970-945-5665), Steamboat Springs (970-879-0272), or Durango (970-247-1845), or refer to our web site at dwr.colorado.gov for general information, additional forms, and access to state rules or statutes.

Case No. 23-102980RZ

Legal Description

Street Location of Property Shadow Mountain Drive

Is there an existing structure at this address?

Yes _____ No X

Type the legal description and address below.

Parcel ID 61-163-00-001 is more particularly described by the metes and bounds of the said 306 acres, it is owned by the Colorado State Land Board. The corner quarter coordinates S 43° 07'29" E and N 00°19'28" W and is a locally preserved 70 acre quarter corner of the used 235 acre parcel #61-00-001. This 70 acre parcel corner sits S of Shadow Mtn Drive Road with road frontage facing the southeast quarter of Shadow Mountain Drive Road containing a R.O.W. of 60'. This quarter corner commences at the S2NW, SE and quarter corner of the NWNW said section 16, Township 6 South Range 71 West of 6th principal Meridian.

Section 16 Township 6 S. Range 71 W.

Calculated Acreage 235.316 Acres

Address Assigned (or verified) (Vacant Land) Shadow Mountain Drive

Attachment B

**ENGINEERING STUDY
for
SHADOW MOUNTAIN BIKE PARK
CONCEPT MASTER PLAN
WATER SYSTEM IMPROVEMENTS**

Prepared For:

**Colorado State Land Board
Shadow Mountain Bike Park
SE Group
Frisco, Colorado
PO Box 2729
323 West Main Street, Suite 202
Frisco, CO 80443-2729**

Prepared By:

Stantec

5725 Mark Dabling Blvd. Suite 190
Colorado Springs CO 80919

**November 2022
Revised October 2023
Revised April 2024
Project No. 181711248**

***** CONTENTS *****

Section 1	EXECUTIVE SUMMARY	1
Section 2	INTRODUCTION	2
2.1	Purpose	2
2.2	Scope	2
Section 3	EXISTING CONDITIONS	3
3.1	Description of Service Area	3
3.2	Land Use	3
3.3	Topography and Floodplains	3
3.4	Geology	3
3.5	Groundwater	3
3.6	Climate	6
3.7	Natural Hazards Analysis	6
3.8	Organizational Context	6
3.9	Water Facilities	6
3.10	Relationship to Neighboring Water and Wastewater Facility	7
3.11	Water Demand	7
Section 4	DEVELOPED CONDITIONS	9
4.1	Land Use	9
4.2	Population and Employment	10
4.3	Water Demand	10
4.4	Water Supply	12
4.5	Water Quality	12
4.6	Fire Flow Requirements	12
Section 5	WATER SYSTEM IMPROVEMENTS	13
5.1	General	13
5.2	Groundwater Wells	13
5.3	Treatment	13
5.4	Storage	13
5.5	Distribution	13
5.6	Estimated Costs	14
5.7	Rates and Charges	14

******* APPENDICES *******

Appendix A	100-Year Flood Plain Certification
Appendix B	Water System Improvement
Appendix C	Water Usage Data

******* LIST OF FIGURES *******

Figure 1	Vicinity Map
----------	--------------

Section 1

EXECUTIVE SUMMARY

This report presents the results of the engineering study for water system improvements serving Shadow Mountain Bike Park proposed on State Land Board Shadow Mountain parcels in Jefferson County, Colorado. Shadow Mountain Bike Park is proposed on undeveloped property with a designated address of 29611 Shadow Mountain Drive, Conifer, Colorado 80433.

The proposed parcel currently has no water facilities on site. Shadow Mountain Bike Park proposes construction of a minimum of one water well to provide potable water to the site facilities through a private water system.

Shadow Mountain Bike Park facilities will consist of a Base Lodge operating as a Class III Recreation facility to welcome guests and provide basic needs such as welcoming center including drinking water and restrooms as well as a maintenance facility for storage and employee use, including water and additional restroom.

The average annual water demand for Shadow Mountain Bike Park is estimated to be 4.72 acre-feet of water per year. Maximum day usage during operations between April 1st and December 31st is estimated to be approximately 5400 gpd or 3.75 gpm. This water will be provided by water wells as permitted by the Colorado State Engineers Office.

To meet Drinking Water Standards water will be filtered (if required) and disinfected prior to storage and will meet Colorado Department of Health and Environment Drinking Water Standards.

Fire Protection is provided by the Elk Creek Fire Protection District. Discussions with District Representatives indicate that they will require on-site fire protection that can provide 1500 gpm for 2 hours. To meet this requirement onsite Fire Storage will need to be 180,000 gallons exclusive of storage required for domestic use. This storage will be provided in a separate Fire Storage only ground storage tank; fire flow will be conveyed to the site through a fire flow distribution system to on-site fire hydrants.

Section 2 INTRODUCTION

2.1 Purpose

The purpose of this report is to present water system improvements recommended to serve Shadow Mountain Bike Park; a proposed recreational development project located in Jefferson County. It is also intended to serve as a guideline for the ensuing design of recommended improvements.

2.2 Scope

The scope of this report includes:

1. The definition of the service areas as well as identification of significant physical and environmental characteristics and constraints.
2. An analysis of available data to determine existing and to project future water supplies, demands and quality.
3. A description of legal, institutional and managerial arrangements that ensure adequate control of the proposed improvements; and,
4. A preliminary recommendation for a selected supply, treatment, pumping and transmission alternatives.

Section 3 EXISTING CONDITIONS

3.1 Description of the Service Area

Shadow Mountain Bike Park consists of approximately 235 acres of Base Lodge (10 acres +/-) and open space uses and is located northwest of Conifer, Colorado, within Township 6 South, Range 71 West, Section 16.

3.2 Land Use

Shadow Mountain Bike Park is in Jefferson County northwest of Conifer, Colorado and about 35 miles southwest of the Denver Metroplex. Surrounding areas are primarily large tract residential properties and large undeveloped tracts.

3.3 Topography and Floodplains

The topography of the service area is typical of a Colorado Front Range Mountain parcel with elevations ranging from 8400 ft. to 9250 ft. above sea level. Existing slopes range from 5% at base camp to 25% or greater in some areas. Vegetation is typical Colorado mountain woodlands with a mix of Ponderosa Pine, Spruce, Fir and ground cover plants and grasses. The area drains generally northeast to North Turkey Creek.

There is no Federal Emergency Management Agency (FEMA 08059CO365F) established floodplain within the boundaries of Shadow Mountain Bike Park. See Appendix A.

3.4 Geology

The site is comprised of several different soil types. From the NRCS Soil Survey of Jefferson County, the site falls into the following soil types:

1. "67" Kittredge-Earcree, 9 to 20 percent slopes; Type A Soil
2. "76" Legault-Hiwan stony loamy sands, 15 to 30 percent slopes; Type D Soil
3. "77" Legault-Hiwan-Rock outcrop complex, 30 to 50 percent slopes; Type D Soil
4. "138" Rock outcrop, igneous and metamorphic; Type D Soil
5. "141" Rogert, very stony-Herbman-Rock outcrop complex, 30 to 70 percent slopes; Type D Soil

Note: "#" indicates Soil Conservation Survey soil classification number.

3.5 Groundwater

The proposed water supply for the Shadow Mountain Bike Park is an onsite water well. The applicant has been in discussion with the State Engineers Office concerning a well permit for the site including the type of permit and the uses permitted to ensure proper permitting. There are numerous wells in the area and discussions with the State indicate issuance of a permit could be made based on water rights associated with the property without injury to adjacent water rights.

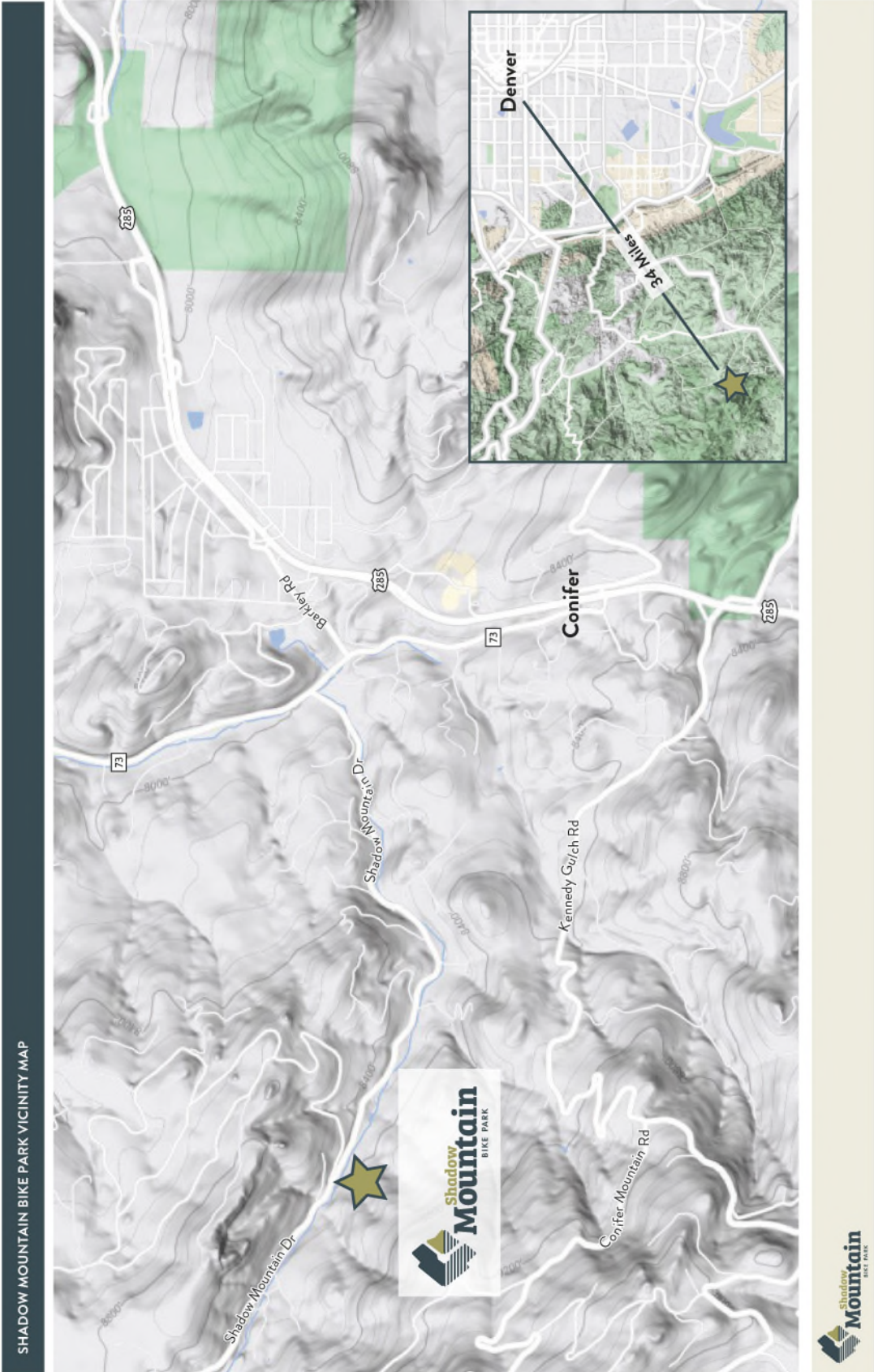

Figure 1: Vicinity Map

3.6 Climate

The climate of the study area is characterized by mild summers and moderately severe winters, moderate precipitation, high evaporation, and moderately high wind velocities.

The average annual monthly temperature is 43.5 F with an average monthly low of 10.3 F in the winter and an average monthly high of 76.1 F in the summer.

Precipitation averages 17.3 inches annually, with 50% of this falling as snow. August is the wettest month and January is the driest. The average annual Class A pan evaporation is 45 inches.

3.7 Natural Hazards Analysis

Natural hazards analysis indicates that no unusual surface or subsurface hazards are located in the service area. However, because the soils are cohesionless, sloughing of steep banks during drilling and/or excavation could occur. By siting improvements in a manner that provides an opportunity to lay the banks of excavations back at a 1:1 slope during construction, the problems associated with sloughing soils can be minimized.

3.8 Organizational Context

Shadow Mountain Bike Park is situated within the North Turkey Creek basin of Jefferson County. The closest public water supplier would be Mountain Water and Sanitation District in Conifer, Colorado. The distance and topography to Conifer in general is cost prohibitive in terms of a water supplier for the bike park.

The amount of water required for the facility and the distance to other providers makes an onsite private water system the best for meeting on-site demands. The Mountain Shadow Bike Park will be the entity responsible for financing, construct and ensure the continuing operation and maintenance of improvements.

3.9 Water Facilities

The proposed water system will consist of a minimum of one water well onsite and water treatment and disinfection based on source water conditions and Colorado Department of Health and Environment requirements. In addition, there will be a 6-inch water transmission line from the water well to the storage tank. Water will be stored to provide peak hour demand and fire sprinkler water for the onsite Base Lodge.

3.10 Relationship to Neighboring Water and Wastewater Facilities

Mountain Water and Sanitation District near Conifer, Colorado is the closest potential provider of water and wastewater facilities. The distance and topography between the site and the town make any connection cost prohibitive.

3.11 Water Demand

The Shadow Mountain Bike Park recreational development will be serviced by a private water system constructed by the developer of the bike park. The projected water demand for the facility is calculated in Section 4.3 Water Demand based on uses recorded at other Bike Park facilities.

Section 4
DEVELOPED CONDITIONS

4.1 Land Use

Mountain Shadow Bike Park consists of approximately 235 acres of State Land Board undeveloped property. Most of the site will be left undeveloped except for the addition of Bike Trails, a bike lift and development of approximately 10 acres for a base lodge including one building for welcoming, ticketing, water facilities and restrooms and one additional building for maintenance and employees with an additional restroom.

Assumptions: Employees water usage is estimated to be 20 gallons per day (gpd)
Guest Water Usage is estimated to be 4 gpd
Irrigation will be minimal or not required with xeriscape or extensions of the natural surroundings.

4.2 Population and Employment

The applicant estimates that there will be up to 30 onsite employees in a given day. The maximum day guest population is estimated to be 1200 as indicated in the applicant's special use plan. Guest and employee populations are estimated to be much lower on average; however, this report has been prepared to estimate maximum uses for water system design.

4.3 Water Demand

Water demand is estimated to be as follows:

Employees	$30 \times 20 \text{ gpd} =$	600 gpd
Guests	$1200 \times 4 \text{ gpd} =$	<u>4800 gpd</u>
	Total =	5400 gpd

These calculations indicate that during a maximum occupancy day the water system would need to be capable of delivering 5400 gpd. Yearly acre-feet requirements assume 275 operating days with guests and that the facility will be staffed year-round with employees. Estimated yearly acre-feet demand is as follows:

Employees	$600 \text{ gpd} \times 365 \text{ days} =$	21,900 gallons = 0.67 ac-ft
Guests	$4800 \text{ gpd} \times 275 \text{ days} =$	1,320,000 gallons = <u>4.05 ac-ft</u>

= 4.72 ac-ft yearly demand

Unit water demands for guests (4 gpd) are based on water usage data from Staunton State Park and Loveland Ski Area (See appendix C). Guest use is planned for 275 days between April and December, outside of the seasonal closure (January 1 through April 1) as defined in the applicant's special use permit. Unit water demands for employees are based on the EPA's Clean Water Toolkit for Sanitary Water Usage based on employees on site 365 days per year.

Water demand is calculated in acre-feet per year (AFY) to determine water supply needs. The maximum guest day is used to determine the average daily demand (ADD) in gallons per minute (gpm), which is used to project maximum day and peak hour demands. Maximum day demand (MDD) and peak hour demand (PHD) have been determined by applying accepted peaking factors of 2.5 and 4.0 to the ADD, respectively. The MDD is used to determine storage needs and the PHD is used for modeling system delivery pressures and to size distribution piping.

Demand

Gallons/day=	5400
ADD gpm=	3.75
MDD gpm=	7.5
PHD gpm=	15.0

Estimated Building Sprinkler demand is 20 gpm for 2 hours or 2400 gallons.

4.4 Water Supply

The proposed water supply for the Shadow Mountain Bike Park is an onsite water well. The applicant has been in discussion with the State Engineers Office concerning a well permit for the site including the type of permit and the uses permitted to ensure proper permitting. There are numerous wells in the area and discussions with the State indicate issuance of a permit could be made based on water rights associated with the property without injury to adjacent water rights. Most of the wells in the area range between 350 ft to over 600 ft. in depth. The nearby wells all indicate access to an “unnamed” aquifer and are all located in a “non-designated” basin.

Based on information from adjacent properties we would anticipate construction and completion of a water well between 500 and 600 ft. in depth in an unnamed aquifer.

The water well permit should be for a well capable of producing at a minimum the anticipated Average Day Demand and overall, yearly withdraw limits should not exceed 4.72 ac-ft annually.

4.5 Water Quality

The water quality and any mitigation required will be determined after construction of the well based on the permit obtained from the State Engineers Office. Mitigation anticipated may include filtering and disinfection. Anticipated treatments expected would be easily obtained with standard readily available locally provided treatment and disinfection equipment.

4.5 Fire Flow

Fire Protection is provided by the Elk Creek Fire Protection District. Discussions with District Representatives indicate that they will require on-site fire protection that can provide 1500 gpm for 2 hours. To meet this requirement onsite Fire Storage will need to be 180,000 gallons exclusive of storage required for domestic use.

In most domestic water systems, the Fire Storage component is 20 to 30% of the overall storage requirement. In this case the Fire Storage component is 94%. Storing water for long periods of time can lead to water quality issues primarily related to taste. Because of this concern, the domestic storage and the fire storage will likely need to be separated.

Fire Storage can be addressed in one of two ways and evaluation of the best alternative will need to continue through the Design Phase to determine the most economical and efficient system.

Ground Storage or Cistern with a Fire Pump

This system would require a 180,000-gallon storage tank approximately 30 feet in diameter and approximately 30 feet tall. Or alternatively a below grade 180,000 gallon cistern approximately 50 feet x 50 feet x 10 feet deep. Along with the storage there would be a requirement to install a 1500 gpm fire pump to deliver water at 20 psi. This type of fire pump would require a 25 HP motor. Included with the design would be a backup generator and fuel storage to provide electricity to the pump if the power failed during a fire.

Ground storage/elevated Fire Storage.

This system would require a 180,000-gallon storage tank approximately 30 feet in diameter and 30 feet tall located at an elevation approximately 50 feet higher than the facility. No fire pump or backup generator would be required, but approximately 2100 feet of transmission pipe would be required to convey water from the site to the tank.

In both cases some pipe would need to be located around the site to distribute to fire hydrant locations (2 maximum).

It would take a 10 gpm well approximately 12.5 days to fill the fire storage tank.

Some type of disinfection and/or aeration may be required in either system to prevent growth of bacteria that could interfere with the distribution of fire flow.

Evaluation of the two potential fire storage options will continue with final design. However, in order to avoid the expense of a large fire pump and backup generator and to use the advantage of gravity flow this report will assume the use of the second option, a ground storage elevated tank.

Section 5
WATER SYSTEM IMPROVEMENTS

5.1 General

The water system would be operated by the Shadow Mountain Bike Park and would be classified as a private water system and would be operated to meet the applicable requirements of the Colorado Department of Public Health and Environment (CDPHE). The system may be operated by a third party contracted by Shadow Mountain Bike Park and licensed by the State of Colorado.

Filtration and disinfection facilities provide treatment of the raw water sources to ensure good water quality. In addition, storage facilities and distribution piping will be provided to ensure that residual pressure requirements are achieved both during peak hour demands and during maximum day demands. The system will also be designed to deliver the required fire sprinkler water to the onsite building.

5.2 Groundwater Wells

The proposed water supply for the Shadow Mountain Bike Park is an onsite water well. As mentioned previously, the applicant has been in contact with the State Engineers Office concerning the parameters of a permit.

The water well permit should be for a well capable of producing at a minimum the anticipated Peak Hour Demand and overall, yearly withdraw limit should exceed 2 ac-ft annually.

The well will be equipped with a submersible well pump capable of delivering in excess of the Average Day Demand of 7.5 gpm. The well pump would be designed to deliver water to the domestic storage tank and fire tank. Final design characteristics will be based on the hydraulic characteristics of the well and the final configuration of the domestic and fire distribution systems.

5.3 Water Treatment

Treating and filtering of the water sources will meet CDPHE Drinking Water Standards.

In addition, CDPHE standards require that the water supply be disinfected and that the supply receives minimum chlorine contact time of 30 minutes before first use.

5.4 Storage

Storage reservoirs will be ground mounted and elevated steel tanks designed in accordance with CDPHE and AWWA Standards.

Potable Water Storage is sized to provide a minimum of 30% of maximum day demand. Required storage is calculated as follows:

Maximum Day Demand is 7.5 gpm. $7.5 \times 60 \times 24 = 10,800$ gallons

Estimated Storage Requirement = 10,800 gallons say 11,000 gallons

Tank size could be doubled to allow for special events (22,000 gallons). Normal operation would be between 8,000 and 12,000 gallons. Actual storage requirements and operational characteristics will be

addressed as final design proceeds.

Fire Demand Storage will be 180,000 gallons as stated in section **4.5 Fire Flow**. Water stored for fire flow will not be considered potable due to disinfection required to maintain functional fire flow storage for long periods of time without use.

5.5 Distribution

The water distribution system provides water at a maximum static pressure of 45 psi during periods of low use and at a minimum residual pressure of 40 psi during peak hour demand. The storage tank will be located at an elevation sufficient to meet these pressure requirements along with associated distribution and conveyance piping. Anticipated transmission and distribution piping is 6-inch.

Fire flow will be conveyed in its own distribution system to 2 fire hydrants located with the fire district input around the site near the building during final design. Each fire hydrant will be capable of conveying 1500 gpm at a minimum pressure of 20 psi. The anticipated fire system piping will be 6-inch minimum diameter.

5.6 Estimated Costs

Estimated Costs

Item	Units	Quantity	Unit Price	Extension
Shadow Mountain Bike Park				
Water Well	LS	1	\$50,000	\$50,000
Well Pump and Controls	LS	1	\$15,000	\$15,000
Potable Water Transmission	LF	5,800	\$35	\$203,000
Potable Storage	Gallons	22,000	\$3	\$66,000
Fire Storage Transmission	LF	2,500	\$35	\$87,500
Fire Storage	Gallons	180,000	\$2	\$360,000
Treatment	LS	1	\$40,000	\$40,000
Total Estimated Cost				<i>\$821,500</i>

The above system improvements are all constructed as part of Shadow Mountain Bike Park. These costs do not include other costs or gains that may be incurred in the acquisition of land, financing, investment, local distribution, the salvage value of equipment or other necessary infrastructure, among others, unless specifically noted. The above costs are estimated, actual costs may differ depending upon numerous factors including supply chain and cost increases at time of bidding.

5.7 Rates and Charges

The waters system will be operated within the overall operation of the Shadow Mountain Bike Park through user fees charged to guests for the recreational facility.

Appendix A

100 Year Flood Plain Certification

Appendix B

Water System Improvements

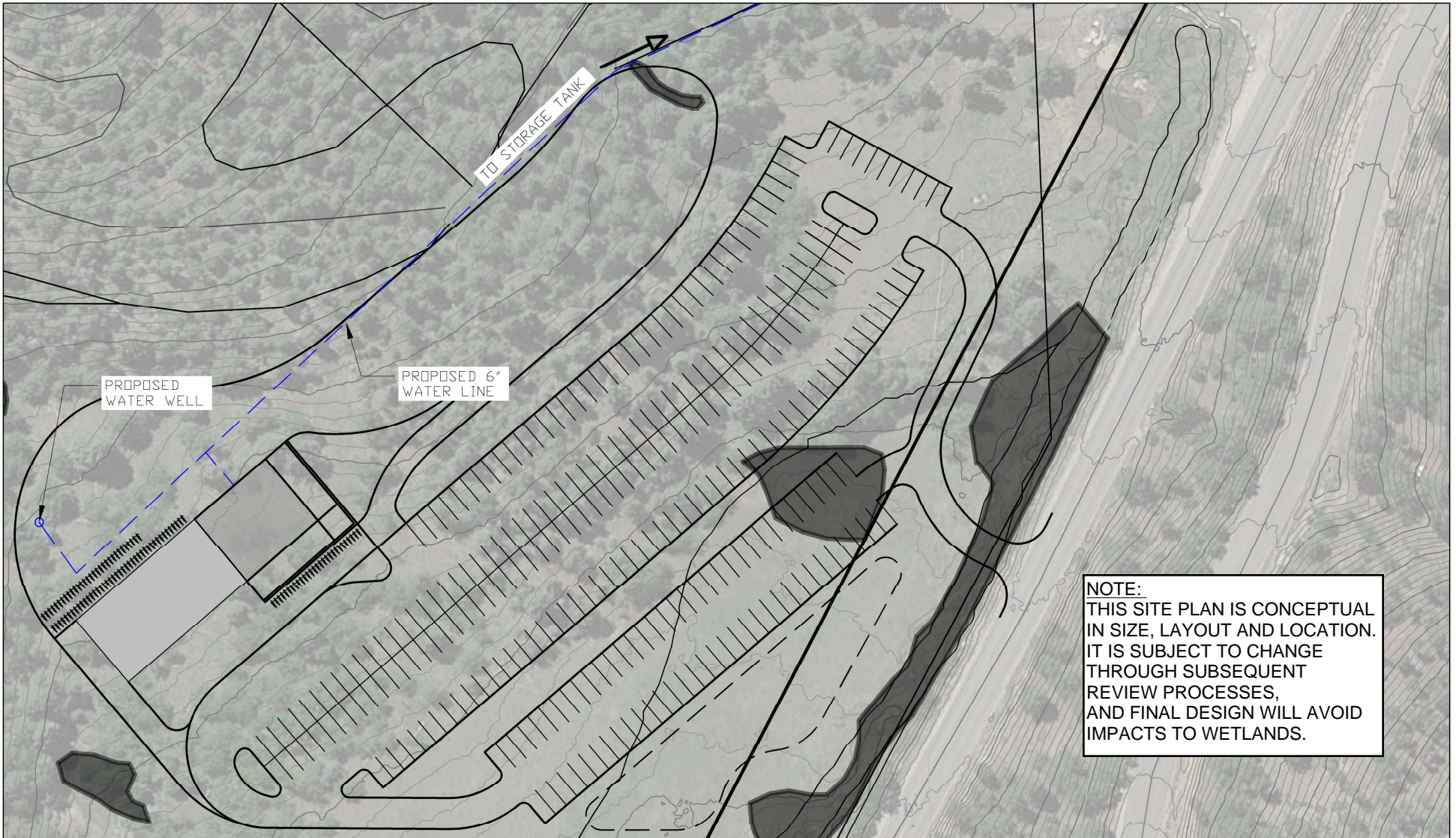

NOTE:
THIS SITE PLAN IS CONCEPTUAL
IN SIZE, LAYOUT AND LOCATION.
IT IS SUBJECT TO CHANGE
THROUGH SUBSEQUENT
REVIEW PROCESSES,
AND FINAL DESIGN WILL AVOID
IMPACTS TO WETLANDS.



2000 S COLORADO BLVD
SUITE 300
DENVER, CO 80222

WATER SYSTEM SITE DRAWING (A)

SHADOW MOUNTAIN BIKE PARK

SCALE: 1"=60'



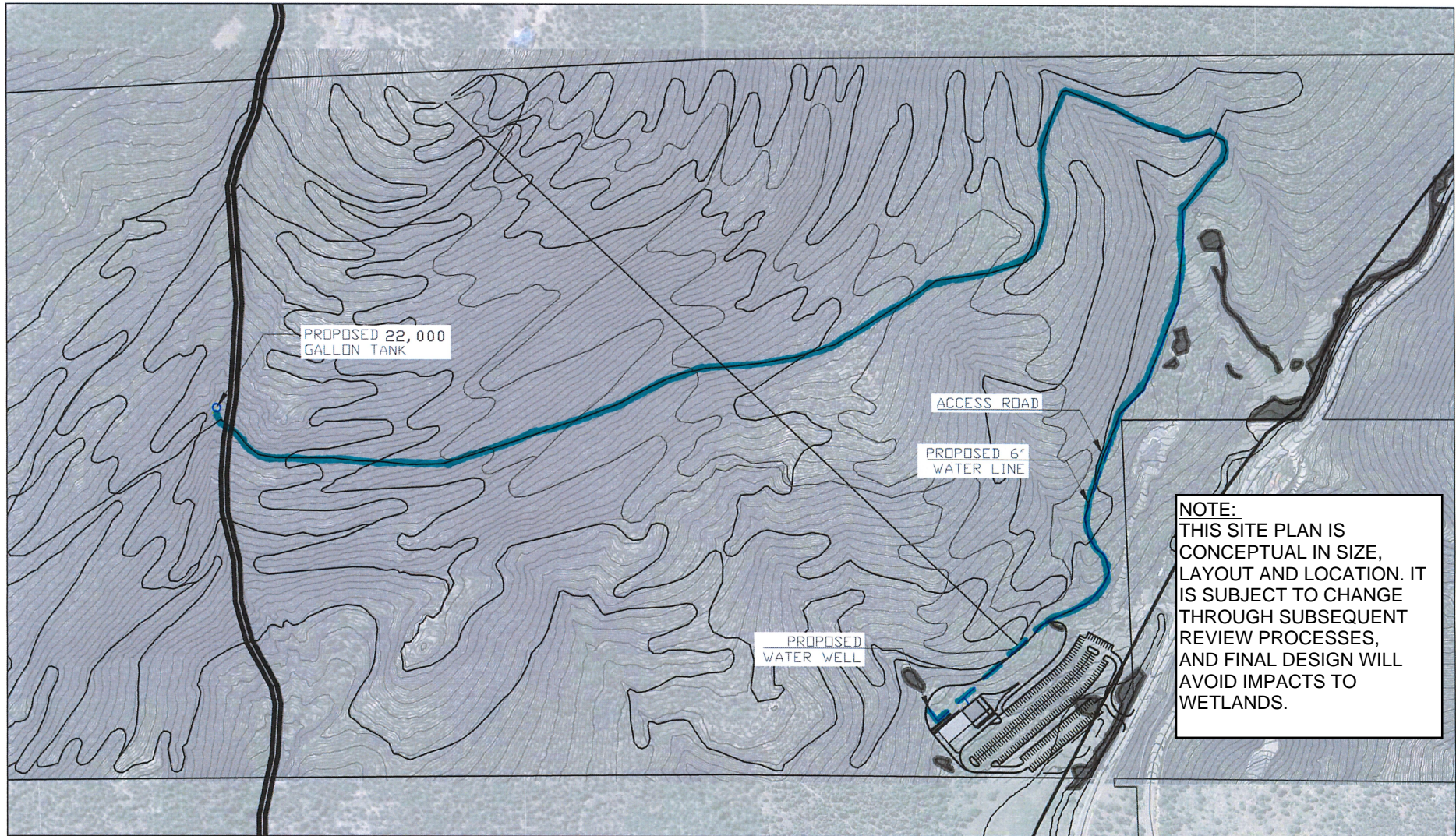

2000 S COLORADO BLVD
SUITE 300
DENVER, CO 80222

WATER SYSTEM SITE DRAWING (B)

SHADOW MOUNTAIN BIKE PARK

SCALE: 1"=300'



Appendix C
Water Usage Data

**Jefferson County - Planning and Zoning Division
Water Requirement Report Worksheet**

Case Number	23-102980RZ
Property Address	-
ODP/Subdivision Name	Shadow Mountain Bike Park
Within MGWOD	Yes
Complies with MGWOD	

1) Calculate Water Withdrawal and Consumptive Water Use of Proposed Development

Type of Proposed Use	Description of Unit	FIXED FIELDS			INPUT	CALCULATED FIELDS			INPUT	Notes
		Annual Withdrawal per Unit (ac-ft per year)	Daily Withdrawal Per Unit (gpd)	Percent Consumptive Use	Number of Units	Total Annual Withdrawal (ac-ft per year)	Total Annual Consumptive Use of Water (ac-ft per year)	Average Water Withdrawal (gpd)	Occupancy Factor Per Year (days)	
Bike Park Guests (weekend)	People	0.00	4	16%	1200	4.05	0.65	4800	275	Seasonal closure Jan 1 to April 1
Bike Park Staff	People	0.02	20	16%	30	0.67	0.11	600	365	
Total						4.72	0.76	5400		

2) Calculate water requirement in terms of acre-feet per acre per year.

$$\frac{5400 \text{ gallons}}{1 \text{ day}} \times \frac{365 \text{ days}}{1 \text{ year}} \times \frac{1 \text{ acre foot}}{325851 \text{ gallons}} \times \frac{1 \text{ project}}{306.0 \text{ acres}} = 0.02 \text{ acre-feet per acre per year}$$

3) Based on water requirements and Section 21 of the LDR, is an Aquifer Test required?

- Since the water requirement does not exceed 0.28 af/a/y, an Aquifer Test is not required with the rezoning application
- Since the water requirement is less than 0.10 af/a/y, an Aquifer Test is not required with the plat or SDP application

4) Aquifer Test Data

WELL DATA		AQUIFER TEST DATA				RECOVERY DATA			
Well Permit Number	Total Depth of Well (ft)	Static Water Level (ft)	Production Rate (gpm)	Extrapolated Production Rate (gpd)	Total Hours Pumped	Water Level When Pumping Stopped (ft)	Recovery-Hours After Pumping (hr)	Recovery-Water Level (ft)	Percent Recovered
Total									

5) Comments

- *Well Permit information not provided by applicant
- *1200 guests maximum based on revised ODP provided by applicant
- *80 bike park staff based on ratio in October 23, 2023 report (300 guest parking & 20 employee parking)
- *Daily guest withdrawal (4 gpd) based on 2021-2023 Staunton State Park water use data (applicant can provide data to County) and Loveland water use data (provided by County)
- *Daily employee withdrawal (20 gpd) based on EPA Lean Water Toolkit for commercial day use facilities without restaurant use (see References sheet)
- *Weekday/weekend visitation ratio from Bogus Basin bike park data for 2023 season (applicant can provide data to County)

Type of Proposed Use	Description of Unit	Annual Withdrawal per Unit (ac-ft per year)	Daily Withdrawal Per Unit (gpd)	Number of Units	Sources	Sq Feet	Description
Bike Park Guests	people		4		Staunton State Park Water Use and Visitation 2021-2023		Maximum use between 2021-2023 was up to 4.4 gallons per guest per day in November-December 2021; this was while Staunton State Park had a leak in their water line. Water use after the leak was fixed, water use was closer to 0.5 gallons per guest per day. Data is from Staunton's visitor center, which has 4 toilets, 4 sinks, and 1 drinking fountain. Thus, the Applicant references 4 gpd per guest as a conservative estimate of water use at a similar facility (parking lot and lodge), which would have a similar number of toilets and has a similar use (outdoor recreation).
Bike Park Employees	people		20		EPA Lean Water Toolkit		

https://dnrc.mt.gov/_docs/water/Water-Rights-Forms/615.pdf

<https://www.jeffco.us/DocumentCenter/View/12324/Jefferson-County-Comprehensive-Master-Plan?bidId=>

<https://www.jeffco.us/DocumentCenter/View/1673/2018-Onsite-Wastewater-Treatment-System-Regulations-PDF?bidId=>

10–25 gallons per person per shift in industrial settings
The lower value is used where there are just toilets.
A higher value is used where there are toilets, showers, and full kitchen services (that is, food preparation and dish washing) **[the lower value is referenced here based on the proposed facility]**
20-35 gallons per employee per day for domestic demands (not including kitchens) in commercial/industrial settings
Savings of 25-35 percent in this domestic usage are readily achievable

[Lean & Water Toolkit: Appendix C | US EPA](#)

Water Availability Analysis of the Proposed Development on the Basin Groundwater Resources

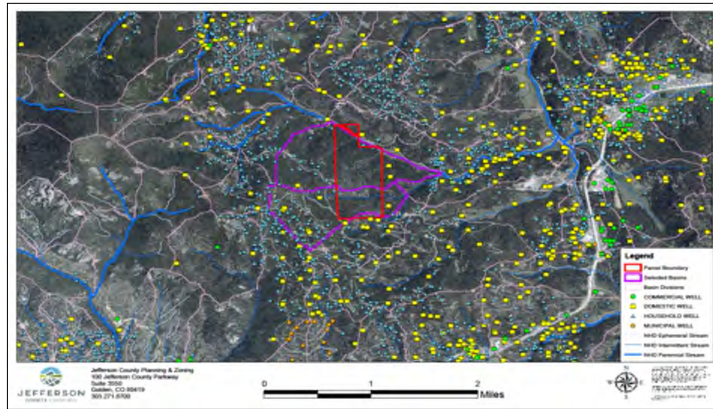

Case Name: Shadow Mountain Bike Park
 Case Number: 23-102980RZ
 Date Prepared: 3.20.24

GIS Calculated
 Parameters
 Auto Calculated

Table 1: Estimate of Available Groundwater Resources in the Basin

Description	Variable or Equation	Value	Units
Basin area	A	753	acres
Average depth to groundwater in the basin (based on well permit data)	B	158	feet
Average depth of wells (based on well permit data)	C	371	feet
Saturated thickness of aquifer exposed to wells	D=C-B	213	feet
Estimated average porosity of aquifer	E	2.0%	
Basin Aquifer Group - alluvium		0%	% of basin
Basin Aquifer Group - highly fractured		1%	% of basin
Basin Aquifer Group - intrusive		63%	% of basin
Basin Aquifer Class - pikes peak		0%	% of basin
Basin Aquifer Group - metamorphic		36%	% of basin
Estimated amount of groundwater in storage	F=A*D*E	3211	acre feet
Effective yield of groundwater to wells	G	50%	
Estimate of groundwater in storage available to wells that are less or equal to the average depth	H=F*G	1605	acre feet
Estimate of groundwater stored in the basin aquifer per foot of saturated thickness	I=A*E*1-foot thick	15.06	acre feet per foot

Table 2: Analysis of Groundwater Withdrawal, Recharge, and Consumptive Use from Existing Wells in Basin

Equation or Variable	J	K	L=J*K	M	N=L*M	O _c =L-N
Type of Wells in Basin	Number of wells in Basin	Estimated amount of groundwater withdrawal in acre feet per year	Estimated amount of groundwater withdrawal in acre feet per year	Estimated percent returned to recharge groundwater	Estimated amount of groundwater recharge in acre feet per year	Estimated Consumptive Use of Water in acre feet per year
Domestic - household use portion	12	0.3	3.6	84%	3.0	0.6
Domestic - livestock watering (4 animals*10 gpd*365 days)		0.04	0.5	0%	0.0	0.5
Domestic - irrigation portion (1-acre*28 inches of water per year)		0.66	7.9	10%	0.8	7.1
Domestic (household use, irrigation, domestic livestock)	12	1	12.0	32%	3.8	8.2
Household Use	57	0.3	17.1	84%	14.4	2.7
Unaccounted HU wells based on existing structures (non vacant lots)	30	0.3	9.0	84%	7.6	1.4
Commercial	0	0.3	0.0	84%	0.0	0.0
Municipal (see comments for well at breakdown)	0	4.60	0.0	84%	0.0	0.0
Totals	99		38.1		25.7	12.4

*Wells may be associated with augmentation plan that allow for a lower withdrawal

Table 3: Estimate of Annual Groundwater Recharge to the Basin from Precipitation

Description	Variable or Equation	Value	Units
Basin area	A	753	acres
Mean annual precipitation based on NWS RFS data	P	19	inches
Average annual precipitation	Q=(P/12)*A	1209	acre feet
Estimated percent of annual precipitation that goes into groundwater recharge	R	3.5%	
Estimate of annual groundwater recharge to the basin from precipitation	S=Q*R	42.3	acre feet

Table 4: Ground Water Resource Impact of Proposed Development

Equation or Variable	J	K	L=J*K	M	N=L*M	O _p =L-N
Well Type Associated With Proposed Development	Number of Proposed Wells	Estimated amount of groundwater withdrawal in acre feet per year	Estimated amount of groundwater withdrawal in acre feet per year	Estimated percent returned to recharge groundwater	Estimated amount of groundwater recharge in acre feet per year	Estimated Consumptive Use of Water in acre feet per year
Domestic (household use, irrigation, domestic livestock)	0	1	0.0	32%	0.00	0.00
Household Use	0	0.30	0.0	84%	0.00	0.00
Commercial	1	4.72	4.7	84%	3.97	0.76
Municipal	0	0.00	0.0	84%	0.00	0.00
Totals	1		4.7		3.97	0.76

*Wells may be associated with augmentation plan that allow for a lower withdrawal than typical well type

Table 5a: Water Availability Analysis on the Basin Based on Existing and Proposed Development

Description	Variable or Equation	Value	Units
Consumptive use impact of existing development (e)	O _e	12.4	acre feet per year
Consumptive use impact of proposed development (p)	O _p	0.76	acre feet per year
Consumptive use impact of existing and proposed development (t)	O _t	13.1	acre feet per year
Estimate of groundwater recharge to the basin from precipitation	S	42.3	acre feet per year
Groundwater Budget=Groundwater Recharge-Total Consumptive Use	T=S-O _t	29.2	acre feet per year

*If groundwater budget value (T) is positive then the water supply appears to be adequate

*If groundwater budget value (T) is negative then the depth to water level will increase over time

Table 5b: Impact on the Basin Based on Existing and Proposed Development With 0 Recharge From Precipitation

Description	Variable or Equation	Value	Units
Estimated percent of aquifer depletion based on consumptive use of proposed development	U=O _p /H	0.05%	
Theoretical "annual average basin wide" drop in water level due to consumptive use of proposed development with 0 recharge from precipitation	V=O _p /I	0.05	feet
Theoretical time it would take to drain the saturated thickness of the basin by the consumptive use of the existing and proposed development with 0 recharge from precipitation	W=D/((O _t)/I)	245	years

Table 5c: Impact on the Basin Based on Existing and Proposed Development Including Estimated Recharge From Precipitation

Description	Variable or Equation	Value	Units
Theoretical time it would take to drain the saturated thickness of the basin by the consumptive use of the existing and proposed development with estimated precipitation recharge	X=D/((T)/I)	NA, since recharge exceeds consumptive use	years

Table 6a: Water Availability Analysis on the Basin Based Existing, on Build out of Platted Lots and Proposed Development

Description	Variable or Equation	Value	Units
Number of lots in basin	Y	116	lots
Number of vacant lots in basin	Z	17	lots
Number of wells associated with proposed development	J	1	wells
Consumptive use impact of build out of vacant lots	AA=Z*K(1-M)	0.82	acre feet per year

Table 6b: Impact on the Basin Based on Build out of Platted Lots and Proposed Development Including 0 Recharge From Precipitation

Description	Variable or Equation	Value	Units
Theoretical "annual average basin wide" drop in water level due to consumptive use at full build out based on platted lots and proposed development with 0 recharge from precipitation	AB=(O _t +AA)/I	0.9	feet
Theoretical time it would take to drain the saturated thickness of the basin by the consumptive use at full build out based on platted lots, existing, and proposed development with 0 recharge from precipitation	AC=D/((O _t +AA)/I)	230	years

Table 6c: Impact on the Basin Based on Build out of Platted Lots and Proposed Development Including Estimated Recharge From Precipitation

Description	Variable or Equation	Value	Units
Theoretical time it would take to drain the saturated thickness of the basin by the consumptive use at full build out based on platted lots, existing, and proposed development with estimated precipitation recharge	AD=D/(((T)+AA)/I)	NA, since recharge exceeds consumptive use	years

Table 7a: Water Availability Analysis on the Basin Based on Build out of Platted Lots, Additional Lots Allowed by Zoning and Proposed Development

Description	Variable or Equation	Value	Units
Number of lots in basin	Y	116	lots
Number of vacant lots in basin	Z	17	lots
Number of wells associated with proposed development	J	1	wells
Estimated number of additional lots allowed based on zoning	AE	53	lots
Consumptive use impact of existing development	O _e	12.4	acre feet per year
Consumptive use impact of build out of vacant lots	AA	0.82	acre feet per year
Consumptive use impact of build out of lots allowed by zoning	AF=AE*K(1-M)	2.54	acre feet per year
Consumptive use impact of proposed development	O _p	0.76	acre feet per year

Table 7b: Impact on the Basin Based on Build out of Platted Lots, Additional Lots Allowed by Zoning and Proposed Development With 0 Recharge From Precipitation

Description	Variable or Equation	Value	Units
-------------	----------------------	-------	-------

Theoretical "annual average basin wide" drop in water level due to consumptive use at full build out based on platted lots, allowed by zoning, and proposed development	$AG=(O_i+AA+AF)/I$	1.1	feet
Theoretical time it would take to drain the saturated thickness of the basin by the consumptive use at full build out based on platted lots, allowed by zoning, existing, and proposed development with 0 precipitation recharge	$AH=D/((O_i+AA+AF)/I)$	195	years

Table 7c: Impact on the Basin Based on Build out of Platted Lots, Additional Lots Allowed by Zoning and Proposed Development With Estimated Recharge From Precipitation

Description	Variable or Equation	Value	Units
Theoretical time it would take to drain the saturated thickness of the basin by the consumptive use at full build out based platted lots, allowed by zoning, existing, and proposed development with estimated precipitation recharge	$AI=D/((IT+AA+AG)/I)$	NA, since recharge exceeds consumptive use	years

Comments:

*Inserted Row 50 to account for HU wells for existing structures (99)

*water budget is positive which indicates an adequate water supply

Misc:

- Standard values to use for the WAA were based on data from the [USGS's 2003 Hydrologic Conditions and Assessment of Water Resources in the Turkey Creek Watershed](#) and [CDM's 2011 Upper Mountain Counties Aquifer Sustainability Project Report](#)
[Link to 2003 USGS Report](#)
[Link to 2011 CDM Report](#)

Data Value Sources & References for the Water Availability Analysis (WAA):

- Basin Area – Defined basins are generated from ArcGIS based on USGS 10 Meter Digital Elevation Model (DEM) with each basin having a minimum area of 5 acres.
- Annual Precipitation – Based on the mean data (2005-2013) from the National Weather Service precipitation estimates from their River Forecast Centers (RFCs) which are on 4 by 4 kilometer grid system. The RFCs information is based on both radar and rain gauge data. The annual observed precipitation data from the closest RFC to the development project will be utilized in the WAA.
<http://water.weather.gov/precip/about.php>
- Estimated Recharge from Precipitation – Based on USGS's 2003 Hydrologic Conditions and Assessment of Water Resources in the Turkey Creek Watershed (2%) and the CDM 2011 Upper Mountain Counties Aquifer Sustainability Project (references USGS study), the estimated recharge from precipitation is 2.0%.
- Estimated Recharge from Wastewater Returns – Based on several sources including the DNRs 1974 Consumptive Use of Water by Homes Utilizing Leach Fields for Sewage Disposal (88%), the Water Center of CSU 2007 Consumptive Loss from an ISDS in a Semi-Arid Mountain Environment (84%), the Journal of Hydrology 2010 Consumptive Use and Resulting Leach-field Drainage from a Mountain Residence (80%), and the CDM 2011 Upper Mountain Counties Aquifer Sustainability Project (references each study) the estimated recharge from wastewater returns is 84%.
- Well Data – ArcGIS data is provided by the Colorado Division of Water Resources. The well data will include the number of wells in the basin and the Use (Household, Domestic, Commercial, etc) to determine the volume of water permitted to be removed from the basin. Mean depth of the well and depth to water in the basin will be calculated from the attribute data. Certain uses (Commercial, Municipal, other) will require staff to review the well permit to determine the permitted withdrawal.
- Aquifer Groups – The (Metamorphic, Intrusive, Pike's Peak, Highly Fractured, and Alluvial) may be used to allow for a range for the Estimated Recharge from Precipitation based on Aquifer Group. Aquifer Group data is based on the CDM 2011 Upper Mountain Counties Aquifer Sustainability Project.

COLORADO DIVISION OF WATER RESOURCES
DEPARTMENT OF NATURAL RESOURCES
1313 SHERMAN ST, RM 821, DENVER, CO 80203
Main: (303) 866-3581 dwrpermitsonline@state.co.us

Office Use Only

Form GWS-45 (01/2020)

GENERAL PURPOSE

Water Well Permit Application

Review instructions on reverse side prior to completing form.
The form must be computer generated, typed or in black or blue ink.

1. Applicant Information

Name of applicant

FSBR, LLC

Mailing address

32372 Lodgepole Drive

City

Evergreen

State

CO

Zip code

80439

Telephone # (area code & number)

603-660-6604

E-mail (online filing required)

phil@shadowmountainbikepark.com

2. Type Of Application (check applicable boxes)

- Construct new well Use existing well
 Replace existing well Change or increase use
 Change source (aquifer) Reapplication (expired permit)
 COGCC Well Other: _____

3. Refer To (if applicable)

Well permit #

Water Court case #

Designated Basin Determination #

Well name or #

4. Location Of Proposed Well

County

Jefferson

1/4 of the _____ 1/4

Section

16

Township

6

N or S

N S

Range

71

E or W

E W

Principal Meridian

6

Distance of well from section lines (section lines are typically not property lines)

1930

Ft. from N S

2105

Ft. from E W

For replacement wells only – distance and direction from old well to new well

feet

direction

Well location address (Include City, State, Zip) Check if well address is same as in Item 1.

Shadow Mountain Drive, Conifer, CO, 80433

Optional: GPS well location information in UTM format You must check GPS unit for required settings as follows:

Format must be UTM

Zone 12 or Zone 13

Units must be Meters

Datum must be NAD83

Unit must be set to true north

Was GPS unit checked for above? YES

Easting _____

Northing _____

Remember to set Datum to NAD83

5. Parcel On Which Well Will Be Located

(PLEASE ATTACH A CURRENT DEED FOR THE SUBJECT PARCEL)

A. Legal Description (may be provided as an attachment):

See attachment

B. # of acres in parcel

306

C. Owner

Colorado State Land Board

D. Will this be the only well on this parcel? YES NO (if no list other wells)

E. State Parcel ID# (optional):

61-163-00-001

6. Use Of Well (check applicable boxes)

Attach a detailed description of uses applied for.

- Industrial Dewatering System
 Municipal Geothermal (production or reinjection)
 Irrigation Other (describe): _____
 Commercial

7. Well Data (proposed)

Maximum pumping rate

7.5

gpm

Annual amount to be withdrawn

4.72

acre-feet

Total depth

600

feet

Aquifer

unnamed

8. Land On Which Ground Water Will Be Used

Legal Description of Land (may be provided as an attachment):

See attachment

(If used for crop irrigation, attach a scaled map that shows irrigated area.)

A. # Acres

306

B. Owner

Colorado State Land Board

C. List any other wells or water rights used on this land:

9. Proposed Well Driller License #(optional):

10. Sign or Entered Name Of Applicant(s) Or Authorized Agent

The making of false statements herein constitutes perjury in the second degree, which is punishable as a class 1 misdemeanor pursuant to C.R.S. 24-4-104 (13)(a). I have read the statements herein, know the contents thereof and state that they are true to my knowledge.

Sign or enter name(s) of person(s) submitting application

Date (mm/dd/yyyy)

If signing print name and title

Office Use Only

USGS map name

DWR map no.

Surface elev.

Receipt area only

AQUAMAP

WE

WR

CWCB

TOPO

MYLAR

SB5

DIV ____ WD ____ BA ____ MD ____

GENERAL PURPOSE WELL PERMIT APPLICATION INSTRUCTIONS

Applications must be computer generated on-line, typewritten or printed in BLACK or BLUE INK. ALL ITEMS in the application must be completed. Incomplete applications may be returned to the applicant for more information. Applications are evaluated in chronological order. Please allow approximately six weeks for processing. This form may be reproduced by photocopying or computer generation. Reproductions must retain margins and print quality of the original form. If filing online see online filing instructions! You may also save, print, scan and email the completed form to: dwrpermitsonline@state.co.us For further information please visit dwr.colorado.gov

FEES: This application requires a nonrefundable \$100.00 filing fee. Please visit [DWR's Online Form Submittal](#) web page for acceptable payment information or contact DWR at (303) 866-3581.

USES: This form (GWS-45) is to be used to apply for commercial, industrial, municipal, irrigation, feed lot, geothermal (see Geothermal Rules for fee requirements), recovery wells, and other uses not otherwise noted in the following list:

RESIDENTIAL use wells – Use of form GWS-44 is required
LIVESTOCK watering on a farm, ranch, range or pasture (not feedlots) – Use form GWS-44
MONITORING/OBSERVATION wells – Use form GWS-46
GRAVEL PITS – Use form GWS-27
REGISTRATION of an existing well – Use form GWS-12 (must have been in use prior to May 8, 1972)
GEOEXCHANGE SYSTEM LOOP FIELDS – Use form GWS-72
REPLACEMENTS OF WELLS FOR THE ABOVE USES

ITEM INSTRUCTIONS: (numbers correspond with those on the front of this form)

1. The applicant is the entity for whom the permit is to be issued. Provide the applicant name and the mailing address where all correspondence will be sent.
2. Check all boxes that apply.
3. Complete all boxes that apply. If the permit is to be issued pursuant to a water court decree or a Designated Basin determination of water right, the case number or determination number must be indicated. If applying to replace or change the use of an existing well, the permit number of the existing well must be indicated.
4. The county, ¼ of the ¼ section designation, section #, township, range, principal meridian, and distances from section lines for the proposed well must be provided. (An option to providing distances from section lines and the ¼ of the ¼ section designation is to provide an accurate GPS location in UTM format. The required GPS unit settings must be as indicated on this form.) Colorado contains two (2) UTM zones. Zone 13 covers most of Colorado. The boundary between Zone 12 and Zone 13 is the 108th Meridian (longitude). West of the 108th Meridian is UTM Zone 12 and east of the 108th Meridian is UTM Zone 13. The 108th Meridian is approximately 57 miles east of the Colorado-Utah state line. On most GPS units, the UTM zone is given as part of the Easting measurement, e.g. 12T0123456. Check the appropriate box for the zone. Provide the property address of the well location if one exists. If it is the same as the mailing address, check the box next to the well location address.
5. **Please attach a current deed for the subject parcel.** Complete all boxes and provide a complete legal description of the parcel of land on which the well will be located. **If filing online please see online filing instructions for how to submit deed and or legal description attachments.**
6. Check all boxes that apply and attach a detailed description of the uses applied for.
7. Complete all boxes.
8. Complete all boxes and provide a legal description of the land areas on which ground water from the proposed well will be used. If agricultural irrigation is a proposed use, provide a map of the land area with proposed irrigated areas accurately drawn, including section numbers and section lines. A list of all other wells or water rights used on the described land must be provided.
9. The well must be constructed by a Colorado licensed well driller, an authorized individual in accordance with the Water Well Construction Rules, 2 CCR 402-2, or under the "private driller" provision as defined in CRS 37-91-102(12). A listing of licensed well drillers/pump installers is available [here](#).
10. The individual signing the application or entering their name and title must be the applicant or an officer of the corporation/company/agency identified as the applicant or their attorney. An authorized agent may also sign the application, if a letter signed by the applicant or their attorney is submitted with the application authorizing that agent to sign or enter their name on the applicant's behalf. If you filled the form out on-line you may save or print, sign, scan and email the form to the Division of Water Resources. Payment must be received via phone, fax or mail prior to processing the application.

IF YOU HAVE ANY QUESTIONS regarding any item on the application form, please call the Division of Water Resources Ground Water Information Desk (303-866-3587), or the nearest Division of Water Resources Field Office located in Greeley (970-352-8712), Pueblo (719-542-3368), Alamosa (719-589-6683), Montrose (970-249-6622), Glenwood Springs (970-945-5665), Steamboat Springs (970-879-0272), or Durango (970-247-1845), or refer to our web site at dwr.colorado.gov for general information, additional forms, and access to state rules or statutes.

Case No. 23-102980RZ

Legal Description

Street Location of Property Shadow Mountain Drive

Is there an existing structure at this address?

Yes _____ No X

Type the legal description and address below.

Parcel ID 61-163-00-001 is more particularly described by the metes and bounds of the said 306 acres, it is owned by the Colorado State Land Board. The corner quarter coordinates S 43° 07'29" E and N 00°19'28" W and is a locally preserved 70 acre quarter corner of the used 235 acre parcel #61-00-001. This 70 acre parcel corner sits S of Shadow Mtn Drive Road with road frontage facing the southeast quarter of Shadow Mountain Drive Road containing a R.O.W. of 60'. This quarter corner commences at the S2NW, SE and quarter corner of the NWNW said section 16, Township 6 South Range 71 West of 6th principal Meridian.

Section 16 Township 6 S. Range 71 W.

Calculated Acreage 235.316 Acres

Address Assigned (or verified) (Vacant Land) Shadow Mountain Drive

Attachment B

**ENGINEERING STUDY
for
SHADOW MOUNTAIN BIKE PARK
CONCEPT MASTER PLAN
WATER SYSTEM IMPROVEMENTS**

Prepared For:

**Colorado State Land Board
Shadow Mountain Bike Park
SE Group
Frisco, Colorado
PO Box 2729
323 West Main Street, Suite 202
Frisco, CO 80443-2729**

Prepared By:

Stantec

5725 Mark Dabling Blvd. Suite 190
Colorado Springs CO 80919

**November 2022
Revised October 2023
Revised April 2024
Project No. 181711248**

***** CONTENTS *****

Section 1	EXECUTIVE SUMMARY	1
Section 2	INTRODUCTION	2
2.1	Purpose	2
2.2	Scope	2
Section 3	EXISTING CONDITIONS	3
3.1	Description of Service Area	3
3.2	Land Use	3
3.3	Topography and Floodplains	3
3.4	Geology	3
3.5	Groundwater	3
3.6	Climate	6
3.7	Natural Hazards Analysis	6
3.8	Organizational Context	6
3.9	Water Facilities	6
3.10	Relationship to Neighboring Water and Wastewater Facility	7
3.11	Water Demand	7
Section 4	DEVELOPED CONDITIONS	9
4.1	Land Use	9
4.2	Population and Employment	10
4.3	Water Demand	10
4.4	Water Supply	12
4.5	Water Quality	12
4.6	Fire Flow Requirements	12
Section 5	WATER SYSTEM IMPROVEMENTS	13
5.1	General	13
5.2	Groundwater Wells	13
5.3	Treatment	13
5.4	Storage	13
5.5	Distribution	13
5.6	Estimated Costs	14
5.7	Rates and Charges	14

******* APPENDICES *******

Appendix A	100-Year Flood Plain Certification
Appendix B	Water System Improvement
Appendix C	Water Usage Data

******* LIST OF FIGURES *******

Figure 1	Vicinity Map
----------	--------------

Section 1

EXECUTIVE SUMMARY

This report presents the results of the engineering study for water system improvements serving Shadow Mountain Bike Park proposed on State Land Board Shadow Mountain parcels in Jefferson County, Colorado. Shadow Mountain Bike Park is proposed on undeveloped property with a designated address of 29611 Shadow Mountain Drive, Conifer, Colorado 80433.

The proposed parcel currently has no water facilities on site. Shadow Mountain Bike Park proposes construction of a minimum of one water well to provide potable water to the site facilities through a private water system.

Shadow Mountain Bike Park facilities will consist of a Base Lodge operating as a Class III Recreation facility to welcome guests and provide basic needs such as welcoming center including drinking water and restrooms as well as a maintenance facility for storage and employee use, including water and additional restroom.

The average annual water demand for Shadow Mountain Bike Park is estimated to be 4.72 acre-feet of water per year. Maximum day usage during operations between April 1st and December 31st is estimated to be approximately 5400 gpd or 3.75 gpm. This water will be provided by water wells as permitted by the Colorado State Engineers Office.

To meet Drinking Water Standards water will be filtered (if required) and disinfected prior to storage and will meet Colorado Department of Health and Environment Drinking Water Standards.

Fire Protection is provided by the Elk Creek Fire Protection District. Discussions with District Representatives indicate that they will require on-site fire protection that can provide 1500 gpm for 2 hours. To meet this requirement onsite Fire Storage will need to be 180,000 gallons exclusive of storage required for domestic use. This storage will be provided in a separate Fire Storage only ground storage tank; fire flow will be conveyed to the site through a fire flow distribution system to on-site fire hydrants.

Section 2 INTRODUCTION

2.1 Purpose

The purpose of this report is to present water system improvements recommended to serve Shadow Mountain Bike Park; a proposed recreational development project located in Jefferson County. It is also intended to serve as a guideline for the ensuing design of recommended improvements.

2.2 Scope

The scope of this report includes:

1. The definition of the service areas as well as identification of significant physical and environmental characteristics and constraints.
2. An analysis of available data to determine existing and to project future water supplies, demands and quality.
3. A description of legal, institutional and managerial arrangements that ensure adequate control of the proposed improvements; and,
4. A preliminary recommendation for a selected supply, treatment, pumping and transmission alternatives.

Section 3 EXISTING CONDITIONS

3.1 Description of the Service Area

Shadow Mountain Bike Park consists of approximately 235 acres of Base Lodge (10 acres +/-) and open space uses and is located northwest of Conifer, Colorado, within Township 6 South, Range 71 West, Section 16.

3.2 Land Use

Shadow Mountain Bike Park is in Jefferson County northwest of Conifer, Colorado and about 35 miles southwest of the Denver Metroplex. Surrounding areas are primarily large tract residential properties and large undeveloped tracts.

3.3 Topography and Floodplains

The topography of the service area is typical of a Colorado Front Range Mountain parcel with elevations ranging from 8400 ft. to 9250 ft. above sea level. Existing slopes range from 5% at base camp to 25% or greater in some areas. Vegetation is typical Colorado mountain woodlands with a mix of Ponderosa Pine, Spruce, Fir and ground cover plants and grasses. The area drains generally northeast to North Turkey Creek.

There is no Federal Emergency Management Agency (FEMA 08059CO365F) established floodplain within the boundaries of Shadow Mountain Bike Park. See Appendix A.

3.4 Geology

The site is comprised of several different soil types. From the NRCS Soil Survey of Jefferson County, the site falls into the following soil types:

1. "67" Kittredge-Earcree, 9 to 20 percent slopes; Type A Soil
2. "76" Legault-Hiwan stony loamy sands, 15 to 30 percent slopes; Type D Soil
3. "77" Legault-Hiwan-Rock outcrop complex, 30 to 50 percent slopes; Type D Soil
4. "138" Rock outcrop, igneous and metamorphic; Type D Soil
5. "141" Rogert, very stony-Herbman-Rock outcrop complex, 30 to 70 percent slopes; Type D Soil

Note: "#" indicates Soil Conservation Survey soil classification number.

3.5 Groundwater

The proposed water supply for the Shadow Mountain Bike Park is an onsite water well. The applicant has been in discussion with the State Engineers Office concerning a well permit for the site including the type of permit and the uses permitted to ensure proper permitting. There are numerous wells in the area and discussions with the State indicate issuance of a permit could be made based on water rights associated with the property without injury to adjacent water rights.

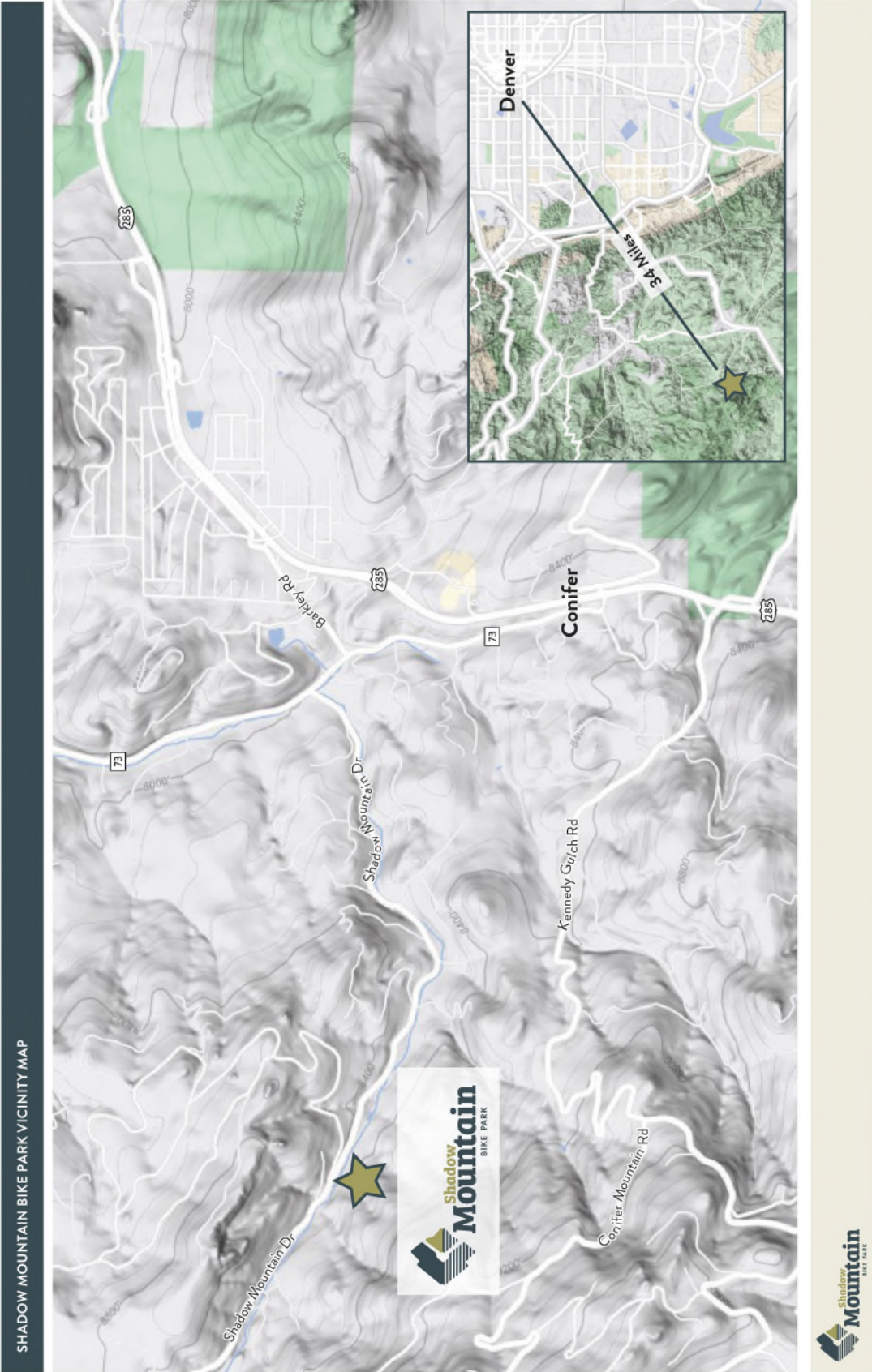

Figure 1: Vicinity Map

3.6 Climate

The climate of the study area is characterized by mild summers and moderately severe winters, moderate precipitation, high evaporation, and moderately high wind velocities.

The average annual monthly temperature is 43.5 F with an average monthly low of 10.3 F in the winter and an average monthly high of 76.1 F in the summer.

Precipitation averages 17.3 inches annually, with 50% of this falling as snow. August is the wettest month and January is the driest. The average annual Class A pan evaporation is 45 inches.

3.7 Natural Hazards Analysis

Natural hazards analysis indicates that no unusual surface or subsurface hazards are located in the service area. However, because the soils are cohesionless, sloughing of steep banks during drilling and/or excavation could occur. By siting improvements in a manner that provides an opportunity to lay the banks of excavations back at a 1:1 slope during construction, the problems associated with sloughing soils can be minimized.

3.8 Organizational Context

Shadow Mountain Bike Park is situated within the North Turkey Creek basin of Jefferson County. The closest public water supplier would be Mountain Water and Sanitation District in Conifer, Colorado. The distance and topography to Conifer in general is cost prohibitive in terms of a water supplier for the bike park.

The amount of water required for the facility and the distance to other providers makes an onsite private water system the best for meeting on-site demands. The Mountain Shadow Bike Park will be the entity responsible for financing, construct and ensure the continuing operation and maintenance of improvements.

3.9 Water Facilities

The proposed water system will consist of a minimum of one water well onsite and water treatment and disinfection based on source water conditions and Colorado Department of Health and Environment requirements. In addition, there will be a 6-inch water transmission line from the water well to the storage tank. Water will be stored to provide peak hour demand and fire sprinkler water for the onsite Base Lodge.

3.10 Relationship to Neighboring Water and Wastewater Facilities

Mountain Water and Sanitation District near Conifer, Colorado is the closest potential provider of water and wastewater facilities. The distance and topography between the site and the town make any connection cost prohibitive.

3.11 Water Demand

The Shadow Mountain Bike Park recreational development will be serviced by a private water system constructed by the developer of the bike park. The projected water demand for the facility is calculated in Section 4.3 Water Demand based on uses recorded at other Bike Park facilities.

Section 4
DEVELOPED CONDITIONS

4.1 Land Use

Mountain Shadow Bike Park consists of approximately 235 acres of State Land Board undeveloped property. Most of the site will be left undeveloped except for the addition of Bike Trails, a bike lift and development of approximately 10 acres for a base lodge including one building for welcoming, ticketing, water facilities and restrooms and one additional building for maintenance and employees with an additional restroom.

Assumptions: Employees water usage is estimated to be 20 gallons per day (gpd)
Guest Water Usage is estimated to be 4 gpd
Irrigation will be minimal or not required with xeriscape or extensions of the natural surroundings.

4.2 Population and Employment

The applicant estimates that there will be up to 30 onsite employees in a given day. The maximum day guest population is estimated to be 1200 as indicated in the applicant's special use plan. Guest and employee populations are estimated to be much lower on average; however, this report has been prepared to estimate maximum uses for water system design.

4.3 Water Demand

Water demand is estimated to be as follows:

Employees	30 x 20 gpd =	600 gpd
Guests	1200 x 4 gpd =	<u>4800 gpd</u>
	Total =	5400 gpd

These calculations indicate that during a maximum occupancy day the water system would need to be capable of delivering 5400 gpd. Yearly acre-feet requirements assume 275 operating days with guests and that the facility will be staffed year-round with employees. Estimated yearly acre-feet demand is as follows:

Employees	600 gpd x 365 days =	21,900 gallons = 0.67 ac-ft
Guests	4800 gpd x 275 days =	1,320,000 gallons = <u>4.05 ac-ft</u>

= 4.72 ac-ft yearly demand

Unit water demands for guests (4 gpd) are based on water usage data from Staunton State Park and Loveland Ski Area (See appendix C). Guest use is planned for 275 days between April and December, outside of the seasonal closure (January 1 through April 1) as defined in the applicant's special use permit. Unit water demands for employees are based on the EPA's Clean Water Toolkit for Sanitary Water Usage based on employees on site 365 days per year.

Water demand is calculated in acre-feet per year (AFY) to determine water supply needs. The maximum guest day is used to determine the average daily demand (ADD) in gallons per minute (gpm), which is used to project maximum day and peak hour demands. Maximum day demand (MDD) and peak hour demand (PHD) have been determined by applying accepted peaking factors of 2.5 and 4.0 to the ADD, respectively. The MDD is used to determine storage needs and the PHD is used for modeling system delivery pressures and to size distribution piping.

Demand

Gallons/day=	5400
ADD gpm=	3.75
MDD gpm=	7.5
PHD gpm=	15.0

Estimated Building Sprinkler demand is 20 gpm for 2 hours or 2400 gallons.

4.4 Water Supply

The proposed water supply for the Shadow Mountain Bike Park is an onsite water well. The applicant has been in discussion with the State Engineers Office concerning a well permit for the site including the type of permit and the uses permitted to ensure proper permitting. There are numerous wells in the area and discussions with the State indicate issuance of a permit could be made based on water rights associated with the property without injury to adjacent water rights. Most of the wells in the area range between 350 ft to over 600 ft. in depth. The nearby wells all indicate access to an “unnamed” aquifer and are all located in a “non-designated” basin.

Based on information from adjacent properties we would anticipate construction and completion of a water well between 500 and 600 ft. in depth in an unnamed aquifer.

The water well permit should be for a well capable of producing at a minimum the anticipated Average Day Demand and overall, yearly withdraw limits should not exceed 4.72 ac-ft annually.

4.5 Water Quality

The water quality and any mitigation required will be determined after construction of the well based on the permit obtained from the State Engineers Office. Mitigation anticipated may include filtering and disinfection. Anticipated treatments expected would be easily obtained with standard readily available locally provided treatment and disinfection equipment.

4.5 Fire Flow

Fire Protection is provided by the Elk Creek Fire Protection District. Discussions with District Representatives indicate that they will require on-site fire protection that can provide 1500 gpm for 2 hours. To meet this requirement onsite Fire Storage will need to be 180,000 gallons exclusive of storage required for domestic use.

In most domestic water systems, the Fire Storage component is 20 to 30% of the overall storage requirement. In this case the Fire Storage component is 94%. Storing water for long periods of time can lead to water quality issues primarily related to taste. Because of this concern, the domestic storage and the fire storage will likely need to be separated.

Fire Storage can be addressed in one of two ways and evaluation of the best alternative will need to continue through the Design Phase to determine the most economical and efficient system.

Ground Storage or Cistern with a Fire Pump

This system would require a 180,000-gallon storage tank approximately 30 feet in diameter and approximately 30 feet tall. Or alternatively a below grade 180,000 gallon cistern approximately 50 feet x 50 feet x 10 feet deep. Along with the storage there would be a requirement to install a 1500 gpm fire pump to deliver water at 20 psi. This type of fire pump would require a 25 HP motor. Included with the design would be a backup generator and fuel storage to provide electricity to the pump if the power failed during a fire.

Ground storage/elevated Fire Storage.

This system would require a 180,000-gallon storage tank approximately 30 feet in diameter and 30 feet tall located at an elevation approximately 50 feet higher than the facility. No fire pump or backup generator would be required, but approximately 2100 feet of transmission pipe would be required to convey water from the site to the tank.

In both cases some pipe would need to be located around the site to distribute to fire hydrant locations (2 maximum).

It would take a 10 gpm well approximately 12.5 days to fill the fire storage tank.

Some type of disinfection and/or aeration may be required in either system to prevent growth of bacteria that could interfere with the distribution of fire flow.

Evaluation of the two potential fire storage options will continue with final design. However, in order to avoid the expense of a large fire pump and backup generator and to use the advantage of gravity flow this report will assume the use of the second option, a ground storage elevated tank.

Section 5
WATER SYSTEM IMPROVEMENTS

5.1 General

The water system would be operated by the Shadow Mountain Bike Park and would be classified as a private water system and would be operated to meet the applicable requirements of the Colorado Department of Public Health and Environment (CDPHE). The system may be operated by a third party contracted by Shadow Mountain Bike Park and licensed by the State of Colorado.

Filtration and disinfection facilities provide treatment of the raw water sources to ensure good water quality. In addition, storage facilities and distribution piping will be provided to ensure that residual pressure requirements are achieved both during peak hour demands and during maximum day demands. The system will also be designed to deliver the required fire sprinkler water to the onsite building.

5.2 Groundwater Wells

The proposed water supply for the Shadow Mountain Bike Park is an onsite water well. As mentioned previously, the applicant has been in contact with the State Engineers Office concerning the parameters of a permit.

The water well permit should be for a well capable of producing at a minimum the anticipated Peak Hour Demand and overall, yearly withdraw limit should exceed 2 ac-ft annually.

The well will be equipped with a submersible well pump capable of delivering in excess of the Average Day Demand of 7.5 gpm. The well pump would be designed to deliver water to the domestic storage tank and fire tank. Final design characteristics will be based on the hydraulic characteristics of the well and the final configuration of the domestic and fire distribution systems.

5.3 Water Treatment

Treating and filtering of the water sources will meet CDPHE Drinking Water Standards.

In addition, CDPHE standards require that the water supply be disinfected and that the supply receives minimum chlorine contact time of 30 minutes before first use.

5.4 Storage

Storage reservoirs will be ground mounted and elevated steel tanks designed in accordance with CDPHE and AWWA Standards.

Potable Water Storage is sized to provide a minimum of 30% of maximum day demand. Required storage is calculated as follows:

Maximum Day Demand is 7.5 gpm. $7.5 \times 60 \times 24 = 10,800$ gallons

Estimated Storage Requirement = 10,800 gallons say 11,000 gallons

Tank size could be doubled to allow for special events (22,000 gallons). Normal operation would be between 8,000 and 12,000 gallons. Actual storage requirements and operational characteristics will be

addressed as final design proceeds.

Fire Demand Storage will be 180,000 gallons as stated in section **4.5 Fire Flow**. Water stored for fire flow will not be considered potable due to disinfection required to maintain functional fire flow storage for long periods of time without use.

5.5 Distribution

The water distribution system provides water at a maximum static pressure of 45 psi during periods of low use and at a minimum residual pressure of 40 psi during peak hour demand. The storage tank will be located at an elevation sufficient to meet these pressure requirements along with associated distribution and conveyance piping. Anticipated transmission and distribution piping is 6-inch.

Fire flow will be conveyed in its own distribution system to 2 fire hydrants located with the fire district input around the site near the building during final design. Each fire hydrant will be capable of conveying 1500 gpm at a minimum pressure of 20 psi. The anticipated fire system piping will be 6-inch minimum diameter.

5.6 Estimated Costs

Estimated Costs

Item	Units	Quantity	Unit Price	Extension
Shadow Mountain Bike Park				
Water Well	LS	1	\$50,000	\$50,000
Well Pump and Controls	LS	1	\$15,000	\$15,000
Potable Water Transmission	LF	5,800	\$35	\$203,000
Potable Storage	Gallons	22,000	\$3	\$66,000
Fire Storage Transmission	LF	2,500	\$35	\$87,500
Fire Storage	Gallons	180,000	\$2	\$360,000
Treatment	LS	1	\$40,000	\$40,000
Total Estimated Cost				<i>\$821,500</i>

The above system improvements are all constructed as part of Shadow Mountain Bike Park. These costs do not include other costs or gains that may be incurred in the acquisition of land, financing, investment, local distribution, the salvage value of equipment or other necessary infrastructure, among others, unless specifically noted. The above costs are estimated, actual costs may differ depending upon numerous factors including supply chain and cost increases at time of bidding.

5.7 Rates and Charges

The waters system will be operated within the overall operation of the Shadow Mountain Bike Park through user fees charged to guests for the recreational facility.

Appendix A

100 Year Flood Plain Certification

Appendix B

Water System Improvements

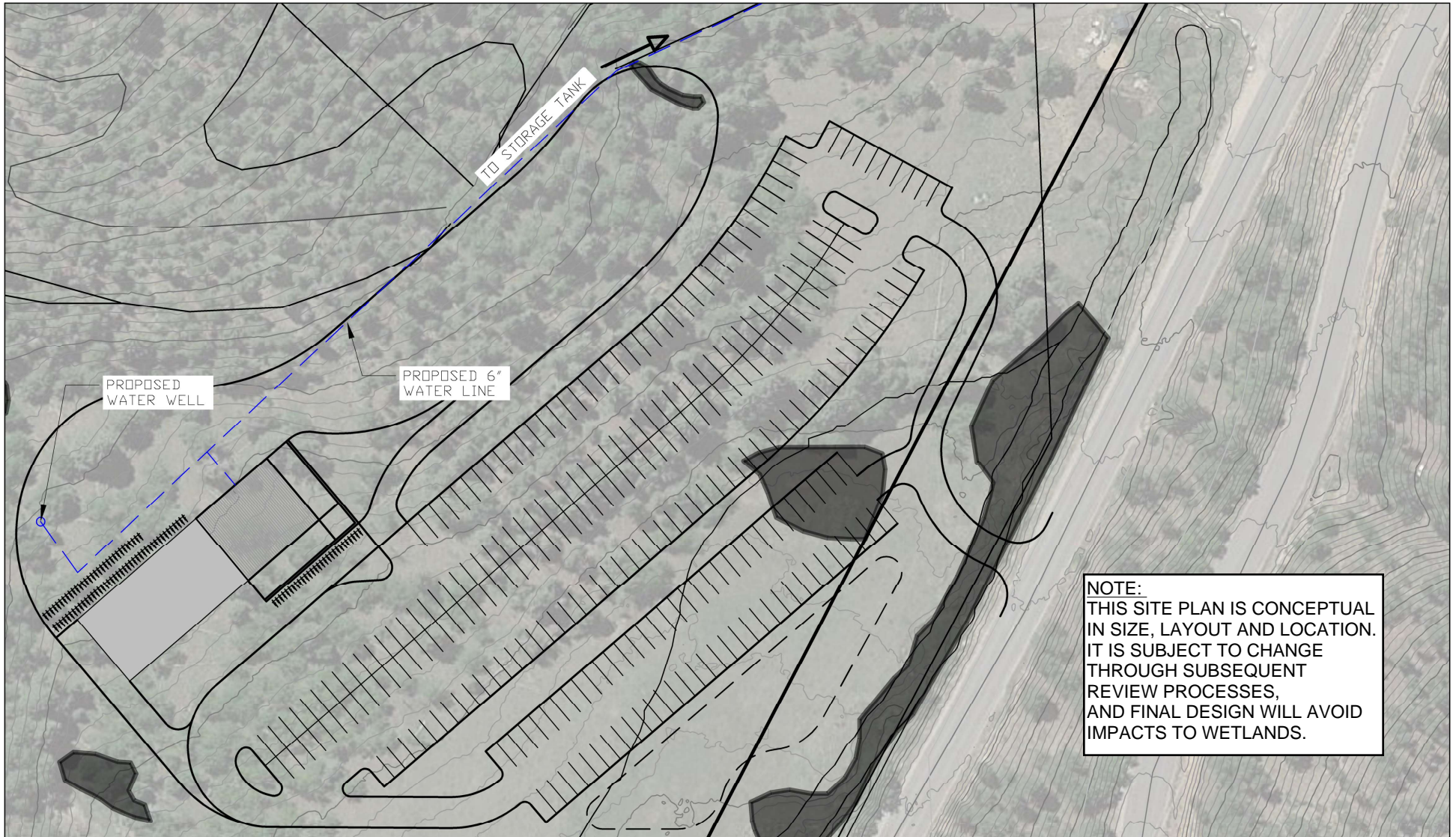

NOTE:
THIS SITE PLAN IS CONCEPTUAL
IN SIZE, LAYOUT AND LOCATION.
IT IS SUBJECT TO CHANGE
THROUGH SUBSEQUENT
REVIEW PROCESSES,
AND FINAL DESIGN WILL AVOID
IMPACTS TO WETLANDS.



2000 S COLORADO BLVD
SUITE 300
DENVER, CO 80222

WATER SYSTEM SITE DRAWING (A)

SHADOW MOUNTAIN BIKE PARK

SCALE: 1"=60'

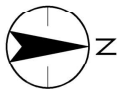

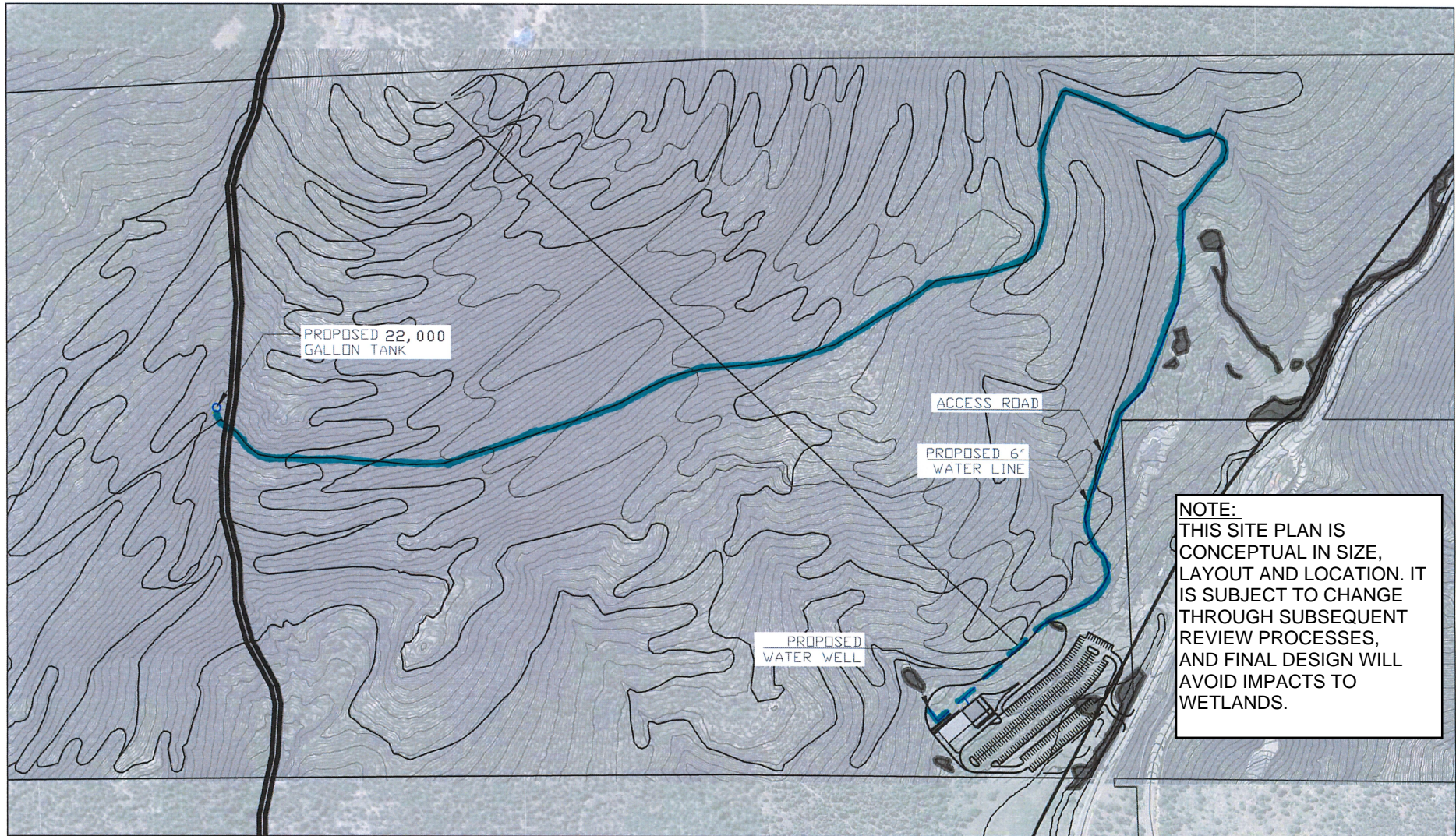

2000 S COLORADO BLVD
SUITE 300
DENVER, CO 80222

WATER SYSTEM SITE DRAWING (B)

SHADOW MOUNTAIN BIKE PARK

SCALE: 1"=300'



Appendix C
Water Usage Data

**Jefferson County - Planning and Zoning Division
Water Requirement Report Worksheet**

Case Number	23-102980RZ
Property Address	-
ODP/Subdivision Name	Shadow Mountain Bike Park
Within MGWOD	Yes
Complies with MGWOD	

1) Calculate Water Withdrawal and Consumptive Water Use of Proposed Development

Type of Proposed Use	Description of Unit	FIXED FIELDS			INPUT	CALCULATED FIELDS			INPUT	Notes
		Annual Withdrawal per Unit (ac-ft per year)	Daily Withdrawal Per Unit (gpd)	Percent Consumptive Use	Number of Units	Total Annual Withdrawal (ac-ft per year)	Total Annual Consumptive Use of Water (ac-ft per year)	Average Water Withdrawal (gpd)	Occupancy Factor Per Year (days)	
Bike Park Guests (weekend)	People	0.00	4	16%	1200	4.05	0.65	4800	275	Seasonal closure Jan 1 to April 1
Bike Park Staff	People	0.02	20	16%	30	0.67	0.11	600	365	
Total						4.72	0.76	5400		

2) Calculate water requirement in terms of acre-feet per acre per year.

$$\frac{5400 \text{ gallons}}{1 \text{ day}} \times \frac{365 \text{ days}}{1 \text{ year}} \times \frac{1 \text{ acre foot}}{325851 \text{ gallons}} \times \frac{1 \text{ project}}{306.0 \text{ acres}} = 0.02 \text{ acre-feet per acre per year}$$

3) Based on water requirements and Section 21 of the LDR, is an Aquifer Test required?

- Since the water requirement does not exceed 0.28 af/a/y, an Aquifer Test is not required with the rezoning application
- Since the water requirement is less than 0.10 af/a/y, an Aquifer Test is not required with the plat or SDP application

4) Aquifer Test Data

WELL DATA		AQUIFER TEST DATA				RECOVERY DATA			
Well Permit Number	Total Depth of Well (ft)	Static Water Level (ft)	Production Rate (gpm)	Extrapolated Production Rate (gpd)	Total Hours Pumped	Water Level When Pumping Stopped (ft)	Recovery-Hours After Pumping (hr)	Recovery-Water Level (ft)	Percent Recovered
Total									

5) Comments

- *Well Permit information not provided by applicant
- *1200 guests maximum based on revised ODP provided by applicant
- *80 bike park staff based on ratio in October 23, 2023 report (300 guest parking & 20 employee parking)
- *Daily guest withdrawal (4 gpd) based on 2021-2023 Staunton State Park water use data (applicant can provide data to County) and Loveland water use data (provided by County)
- *Daily employee withdrawal (20 gpd) based on EPA Lean Water Toolkit for commercial day use facilities without restaurant use (see References sheet)
- *Weekday/weekend visitation ratio from Bogus Basin bike park data for 2023 season (applicant can provide data to County)

Type of Proposed Use	Description of Unit	Annual Withdrawal per Unit (ac-ft per year)	Daily Withdrawal Per Unit (gpd)	Number of Units	Sources	Sq Feet	Description
Bike Park Guests	people		4		Staunton State Park Water Use and Visitation 2021-2023		Maximum use between 2021-2023 was up to 4.4 gallons per guest per day in November-December 2021; this was while Staunton State Park had a leak in their water line. Water use after the leak was fixed, water use was closer to 0.5 gallons per guest per day. Data is from Staunton's visitor center, which has 4 toilets, 4 sinks, and 1 drinking fountain. Thus, the Applicant references 4 gpd per guest as a conservative estimate of water use at a similar facility (parking lot and lodge), which would have a similar number of toilets and has a similar use (outdoor recreation).
Bike Park Employees	people		20		EPA Lean Water Toolkit		

https://dnrc.mt.gov/_docs/water/Water-Rights-Forms/615.pdf

<https://www.jeffco.us/DocumentCenter/View/12324/Jefferson-County-Comprehensive-Master-Plan?bidId=>

<https://www.jeffco.us/DocumentCenter/View/1673/2018-Onsite-Wastewater-Treatment-System-Regulations-PDF?bidId=>

10–25 gallons per person per shift in industrial settings
The lower value is used where there are just toilets.
A higher value is used where there are toilets, showers, and full kitchen services (that is, food preparation and dish washing) **[the lower value is referenced here based on the proposed facility]**
20-35 gallons per employee per day for domestic demands (not including kitchens) in commercial/industrial settings
Savings of 25-35 percent in this domestic usage are readily achievable

[Lean & Water Toolkit: Appendix C | US EPA](#)

Water Availability Analysis of the Proposed Development on the Basin Groundwater Resources

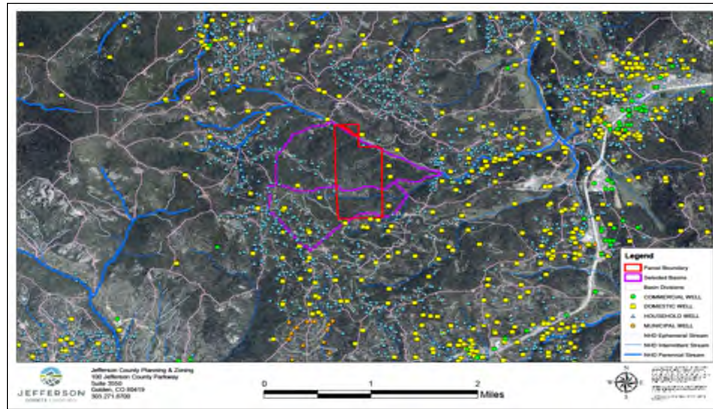

Case Name: Shadow Mountain Bike Park
 Case Number: 23-102980RZ
 Date Prepared: 3.20.24

GIS Calculated
 Parameters
 Auto Calculated

Table 1: Estimate of Available Groundwater Resources in the Basin

Description	Variable or Equation	Value	Units
Basin area	A	753	acres
Average depth to groundwater in the basin (based on well permit data)	B	158	feet
Average depth of wells (based on well permit data)	C	371	feet
Saturated thickness of aquifer exposed to wells	D=C-B	213	feet
Estimated average porosity of aquifer	E	2.0%	
Basin Aquifer Group - alluvium		0%	% of basin
Basin Aquifer Group - highly fractured		1%	% of basin
Basin Aquifer Group - intrusive		63%	% of basin
Basin Aquifer Class - pikes peak		0%	% of basin
Basin Aquifer Group - metamorphic		36%	% of basin
Estimated amount of groundwater in storage	F=A*D*E	3211	acre feet
Effective yield of groundwater to wells	G	50%	
Estimate of groundwater in storage available to wells that are less or equal to the average depth	H=F*G	1605	acre feet
Estimate of groundwater stored in the basin aquifer per foot of saturated thickness	I=A*E*1-foot thick	15.06	acre feet per foot

Table 2: Analysis of Groundwater Withdrawal, Recharge, and Consumptive Use from Existing Wells in Basin

Equation or Variable	J	K	L=J*K	M	N=L*M	O _c =L-N
Type of Wells in Basin	Number of wells in Basin	Estimated amount of groundwater withdrawal in acre feet per year	Estimated amount of groundwater withdrawal in acre feet per year	Estimated percent returned to recharge groundwater	Estimated amount of groundwater recharge in acre feet per year	Estimated Consumptive Use of Water in acre feet per year
Domestic - household use portion	12	0.3	3.6	84%	3.0	0.6
Domestic - livestock watering (4 animals*10 gpd*365 days)		0.04	0.5	0%	0.0	0.5
Domestic - irrigation portion (1-acre*28 inches of water per year)		0.66	7.9	10%	0.8	7.1
Domestic (household use, irrigation, domestic livestock)	12	1	12.0	32%	3.8	8.2
Household Use	57	0.3	17.1	84%	14.4	2.7
Unaccounted HU wells based on existing structures (non vacant lots)	30	0.3	9.0	84%	7.6	1.4
Commercial	0	0.3	0.0	84%	0.0	0.0
Municipal (see comments for well at breakdown)	0	4.60	0.0	84%	0.0	0.0
Totals	99		38.1		25.7	12.4

*Wells may be associated with augmentation plan that allow for a lower withdrawal

Table 3: Estimate of Annual Groundwater Recharge to the Basin from Precipitation

Description	Variable or Equation	Value	Units
Basin area	A	753	acres
Mean annual precipitation based on NWS RFS data	P	19	inches
Average annual precipitation	Q=(P/12)*A	1209	acre feet
Estimated percent of annual precipitation that goes into groundwater recharge	R	3.5%	
Estimate of annual groundwater recharge to the basin from precipitation	S=Q*R	42.3	acre feet

Table 4: Ground Water Resource Impact of Proposed Development

Equation or Variable	J	K	L=J*K	M	N=L*M	O _p =L-N
Well Type Associated With Proposed Development	Number of Proposed Wells	Estimated amount of groundwater withdrawal in acre feet per year	Estimated amount of groundwater withdrawal in acre feet per year	Estimated percent returned to recharge groundwater	Estimated amount of groundwater recharge in acre feet per year	Estimated Consumptive Use of Water in acre feet per year
Domestic (household use, irrigation, domestic livestock)	0	1	0.0	32%	0.00	0.00
Household Use	0	0.30	0.0	84%	0.00	0.00
Commercial	1	4.72	4.7	84%	3.97	0.76
Municipal	0	0.00	0.0	84%	0.00	0.00
Totals	1		4.7		3.97	0.76

*Wells may be associated with augmentation plan that allow for a lower withdrawal than typical well type

Table 5a: Water Availability Analysis on the Basin Based on Existing and Proposed Development

Description	Variable or Equation	Value	Units
Consumptive use impact of existing development (e)	O _e	12.4	acre feet per year
Consumptive use impact of proposed development (p)	O _p	0.76	acre feet per year
Consumptive use impact of existing and proposed development (t)	O _t	13.1	acre feet per year
Estimate of groundwater recharge to the basin from precipitation	S	42.3	acre feet per year
Groundwater Budget=Groundwater Recharge-Total Consumptive Use	T=S-O _t	29.2	acre feet per year

*If groundwater budget value (T) is positive then the water supply appears to be adequate

*If groundwater budget value (T) is negative then the depth to water level will increase over time

Table 5b: Impact on the Basin Based on Existing and Proposed Development With 0 Recharge From Precipitation

Description	Variable or Equation	Value	Units
Estimated percent of aquifer depletion based on consumptive use of proposed development	U=O _p /H	0.05%	
Theoretical "annual average basin wide" drop in water level due to consumptive use of proposed development with 0 recharge from precipitation	V=O _p /I	0.05	feet
Theoretical time it would take to drain the saturated thickness of the basin by the consumptive use of the existing and proposed development with 0 recharge from precipitation	W=D/((O _t)/I)	245	years

Table 5c: Impact on the Basin Based on Existing and Proposed Development Including Estimated Recharge From Precipitation

Description	Variable or Equation	Value	Units
Theoretical time it would take to drain the saturated thickness of the basin by the consumptive use of the existing and proposed development with estimated precipitation recharge	X=D/((T)/I)	NA, since recharge exceeds consumptive use	years

Table 6a: Water Availability Analysis on the Basin Based Existing, on Build out of Platted Lots and Proposed Development

Description	Variable or Equation	Value	Units
Number of lots in basin	Y	116	lots
Number of vacant lots in basin	Z	17	lots
Number of wells associated with proposed development	J	1	wells
Consumptive use impact of build out of vacant lots	AA=Z*K(1-M)	0.82	acre feet per year

Table 6b: Impact on the Basin Based on Build out of Platted Lots and Proposed Development Including 0 Recharge From Precipitation

Description	Variable or Equation	Value	Units
Theoretical "annual average basin wide" drop in water level due to consumptive use at full build out based on platted lots and proposed development with 0 recharge from precipitation	AB=(O _t +AA)/I	0.9	feet
Theoretical time it would take to drain the saturated thickness of the basin by the consumptive use at full build out based on platted lots, existing, and proposed development with 0 recharge from precipitation	AC=D/((O _t +AA)/I)	230	years

Table 6c: Impact on the Basin Based on Build out of Platted Lots and Proposed Development Including Estimated Recharge From Precipitation

Description	Variable or Equation	Value	Units
Theoretical time it would take to drain the saturated thickness of the basin by the consumptive use at full build out based on platted lots, existing, and proposed development with estimated precipitation recharge	AD=D/(((T)+AA)/I)	NA, since recharge exceeds consumptive use	years

Table 7a: Water Availability Analysis on the Basin Based on Build out of Platted Lots, Additional Lots Allowed by Zoning and Proposed Development

Description	Variable or Equation	Value	Units
Number of lots in basin	Y	116	lots
Number of vacant lots in basin	Z	17	lots
Number of wells associated with proposed development	J	1	wells
Estimated number of additional lots allowed based on zoning	AE	53	lots
Consumptive use impact of existing development	O _e	12.4	acre feet per year
Consumptive use impact of build out of vacant lots	AA	0.82	acre feet per year
Consumptive use impact of build out of lots allowed by zoning	AF=AE*K(1-M)	2.54	acre feet per year
Consumptive use impact of proposed development	O _p	0.76	acre feet per year

Table 7b: Impact on the Basin Based on Build out of Platted Lots, Additional Lots Allowed by Zoning and Proposed Development With 0 Recharge From Precipitation

Description	Variable or Equation	Value	Units
-------------	----------------------	-------	-------

Theoretical "annual average basin wide" drop in water level due to consumptive use at full build out based on platted lots, allowed by zoning, and proposed development	$AG=(O_i+AA+AF)/I$	1.1	feet
Theoretical time it would take to drain the saturated thickness of the basin by the consumptive use at full build out based on platted lots, allowed by zoning, existing, and proposed development with 0 precipitation recharge	$AH=D/((O_i+AA+AF)/I)$	195	years

Table 7c: Impact on the Basin Based on Build out of Platted Lots, Additional Lots Allowed by Zoning and Proposed Development With Estimated Recharge From Precipitation

Description	Variable or Equation	Value	Units
Theoretical time it would take to drain the saturated thickness of the basin by the consumptive use at full build out based platted lots, allowed by zoning, existing, and proposed development with estimated precipitation recharge	$AI=D/((IT+AA+AG)/I)$	NA, since recharge exceeds consumptive use	years

Comments:

*Inserted Row 50 to account for HU wells for existing structures (99)

*water budget is positive which indicates an adequate water supply

Misc:

- Standard values to use for the WAA were based on data from the [USGS's 2003 Hydrologic Conditions and Assessment of Water Resources in the Turkey Creek Watershed](#) and [CDM's 2011 Upper Mountain Counties Aquifer Sustainability Project Report](#)
[Link to 2003 USGS Report](#)
[Link to 2011 CDM Report](#)

Data Value Sources & References for the Water Availability Analysis (WAA):

- Basin Area – Defined basins are generated from ArcGIS based on USGS 10 Meter Digital Elevation Model (DEM) with each basin having a minimum area of 5 acres.
- Annual Precipitation – Based on the mean data (2005-2013) from the National Weather Service precipitation estimates from their River Forecast Centers (RFCs) which are on 4 by 4 kilometer grid system. The RFCs information is based on both radar and rain gauge data. The annual observed precipitation data from the closest RFC to the development project will be utilized in the WAA.
<http://water.weather.gov/precip/about.php>
- Estimated Recharge from Precipitation – Based on USGS's 2003 Hydrologic Conditions and Assessment of Water Resources in the Turkey Creek Watershed (2%) and the CDM 2011 Upper Mountain Counties Aquifer Sustainability Project (references USGS study), the estimated recharge from precipitation is 2.0%.
- Estimated Recharge from Wastewater Returns – Based on several sources including the DNRs 1974 Consumptive Use of Water by Homes Utilizing Leach Fields for Sewage Disposal (88%), the Water Center of CSU 2007 Consumptive Loss from an ISDS in a Semi-Arid Mountain Environment (84%), the Journal of Hydrology 2010 Consumptive Use and Resulting Leach-field Drainage from a Mountain Residence (80%), and the CDM 2011 Upper Mountain Counties Aquifer Sustainability Project (references each study) the estimated recharge from wastewater returns is 84%.
- Well Data – ArcGIS data is provided by the Colorado Division of Water Resources. The well data will include the number of wells in the basin and the Use (Household, Domestic, Commercial, etc) to determine the volume of water permitted to be removed from the basin. Mean depth of the well and depth to water in the basin will be calculated from the attribute data. Certain uses (Commercial, Municipal, other) will require staff to review the well permit to determine the permitted withdrawal.
- Aquifer Groups – The (Metamorphic, Intrusive, Pike's Peak, Highly Fractured, and Alluvial) may be used to allow for a range for the Estimated Recharge from Precipitation based on Aquifer Group. Aquifer Group data is based on the CDM 2011 Upper Mountain Counties Aquifer Sustainability Project.